

# PNF Pre-Onboarding / Onboarding & Modeling to Support 5G RAN



- ONAP Modeling
- PNF Onboarding

Benjamin Cheung, PhD 

Michela Bevilacqua 

Zu Qiang 

Mar 18, 2019 version 6 / 3:45PM Pythagore, Nozay, France

# Onboarding and Design Time



	Onboarding Package	Onboarding Descriptor	Platform ONAP Model	SDC CSAR Artifacts	NF Instance
WHAT	 PNF Package Artifacts (CSAR)	 PNF Descriptor Model	 Platform Information Model Platform Data Model	 CSAR (VSP, VF, Service)	 NF Discovery, Instantiation Run time Catalog
WHEN	 Package Delivery	 Pre-Onboarding	 Onboarding	 Design Time	 Run Time
WHO	 Vendor	 Technology Specialist Asset Manager	 Technology Specialist Asset Manager	 Service Designer Operations Specialist	 Operations Specialist
	SOL 004 Package	SOL 001 PNFD	-	-	-

# Onboarding and Design Time



	xNF Package	Validation	Resource Creation	Service Creation	Service Instantiation
WHAT	 xNF Package Artifacts (CSAR) xNF Descriptor Model	 Validating xNF Package	 Platform Information Model Platform Data Model	 Service CSAR (VSP, VF, Service)	 NF Discovery, Instantiation Run time Catalog
WHEN	Package Delivery 	Pre-Onboarding 	Onboarding 	Design Time 	Run Time 
WHO	Vendor 	Technology Specialist Asset Manager 	Technology Specialist Asset Manager 	Service Designer Operations Specialist 	Operations Specialist 
	SOL 004 Package SOL 001 xNFD	SOL 004 Package	-	-	-

# Pre-onboarding/Onboarding in Design Time



WHAT

xNF Package



xNF Package Artifacts (CSAR)  
PNF Descriptor Model

Validation



Validating xNF Package

Resource Creation



Platform Information Model  
Platform Data Model

Service Creation



Service CSAR  
(VSP, VF, Service)

Service Instantiation



NF Discovery, Instantiation  
Run time Catalog

WHEN

Package Delivery



Pre-Onboarding



Onboarding



Design Time



Run Time



KEY INFO

Onboarding Package

VNF-SDK Validation

Resource CSAR

Service CSAR Creation

Service Instantiation

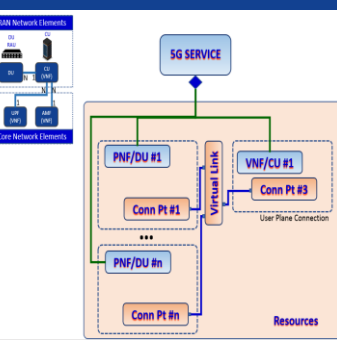
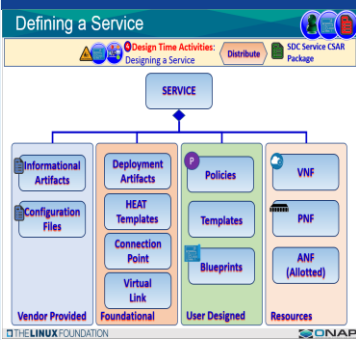
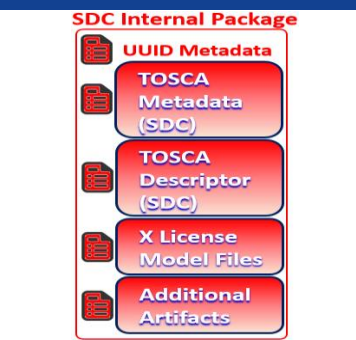
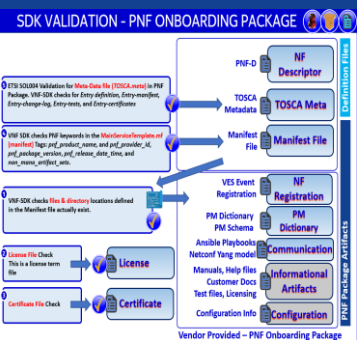
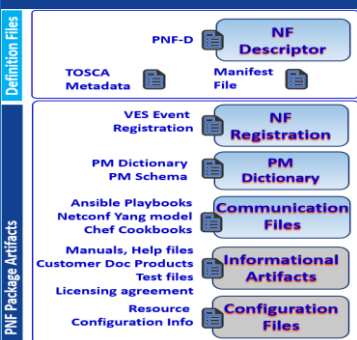

SOL 004 Package  
SOL 001 xNFD

SOL 001 PNF

TOSCA/AID model

AID Model

-











# Pre-onboarding/Onboarding in Design Time





	xNF Package	Validation	Resource Creation	Service Creation	Service Instantiation
WHAT	 VNF Package Artifacts (CSAR) VNF Descriptor Model	 Validating VNF Package	 Platform Information Model Platform Data Model	 Service CSAR (VSP, VF, Service)	 NF Discovery, Instantiation Run time Catalog
WHEN	Package Delivery 	Pre-Onboarding 	Onboarding 	Design Time 	Run Time 
KEY INFO	Onboarding Package -	VNF-SDK Validation -	Resource CSAR <b>SDC Internal Package</b> UUID Metadata TOSCA Metadata (SDC) TOSCA Descriptor (SDC) X License Model Files Additional Artifacts TOSCA/AID model	Service CSAR Creation Defining a Service  AID Model	Service Instantiation  -

# Onboarding and Design Time



Onboarding Package 
Pre/Onboarding 
Vendor 
<b>NF Descriptor</b> 
<b>NF Registration</b> 
<b>PM Dictionary</b> 
<b>PM Schema</b> 
<b>Communication Files</b> 
<b>Informational Artifacts</b> 
<b>Configuration Files</b> 

NF Descriptor 
Pre/Onboarding 
Asset Manager 
<b>PNF Onboarding Package</b> 
<b>SDC Catalog</b> 

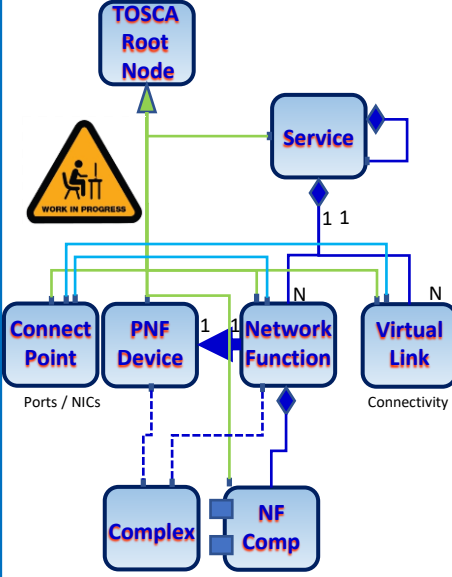
Platform Model 
Design Time 
Service Designer 
<i>Current Platform Data Model Vs. Target Platform Data Model</i>

NF Instance 
Run Time 
Operations 
<b>A&amp;AI</b> 
<b>PNF Instance</b>

# PNF PRE-ONBOARDING/ONBOARDING U/C OVERVIEW

**1 PNF Package Delivery:** Vendor creates & delivers PNF Package with PNF artifacts

**2 PNF Pre-Onboarding** (optional): VNF-SDK (⚠️) can create or validate PNF Onboarding Package

**3 PNF Onboarding:** PNF Package is loaded

**4 Design Time Activities:** NF Onboard Package > SDC catalog

**5 ONAP RT Components:** Ingest and use CSAR package

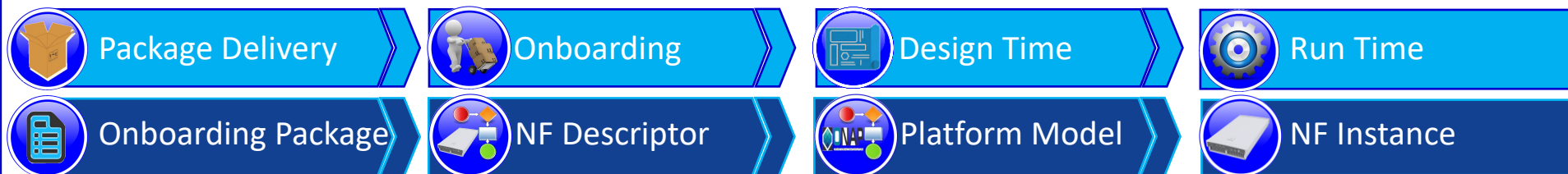
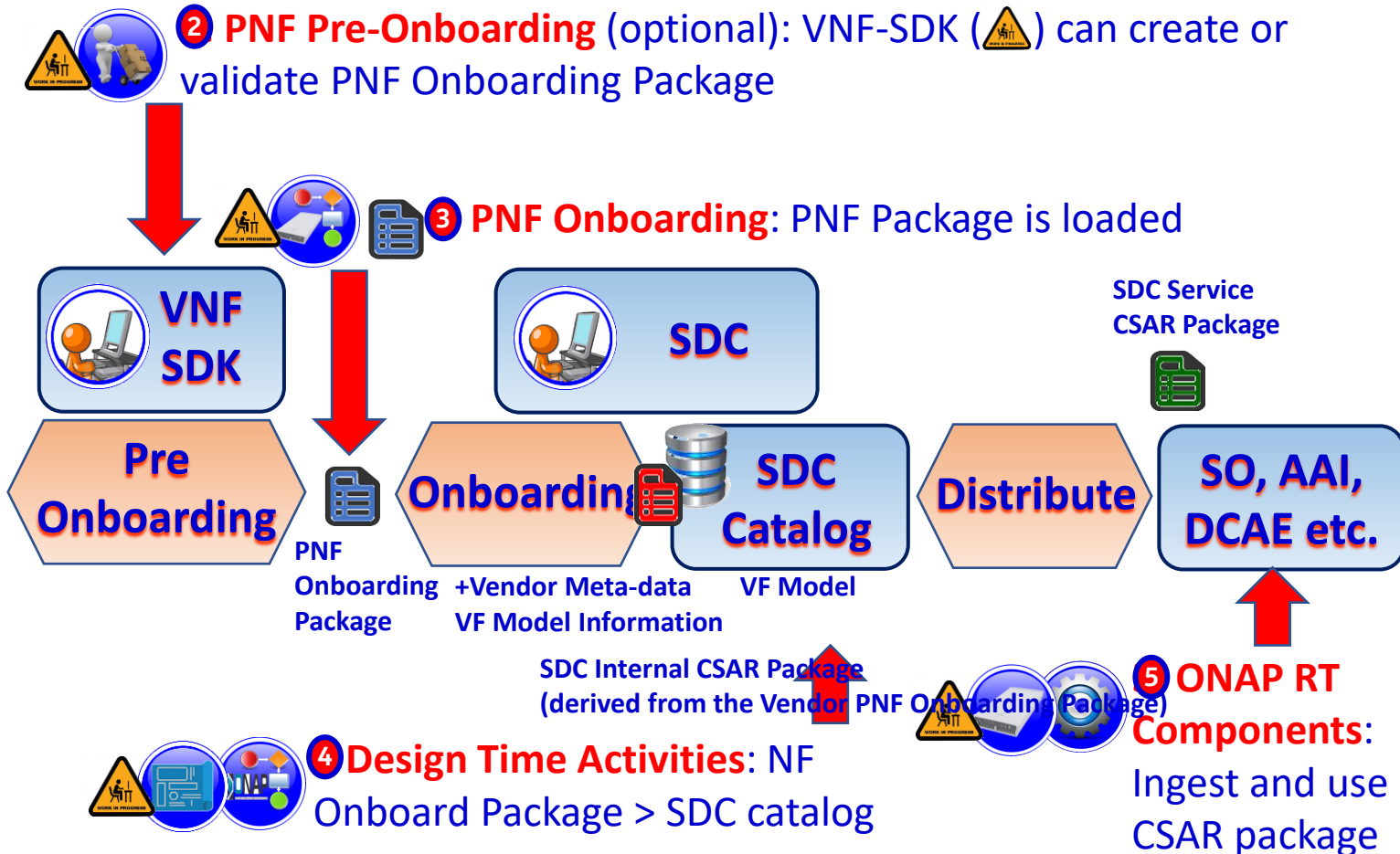
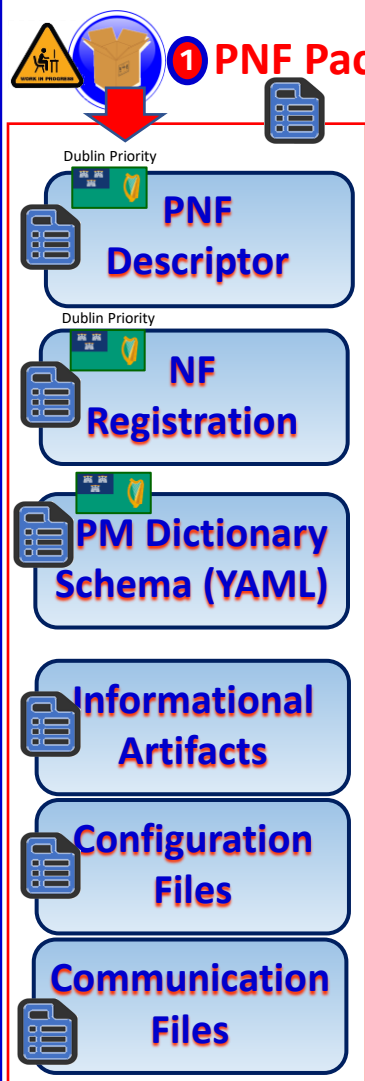

# DUBLIN DEVELOPMENT STATUS



COMPONENT	IMPACTS DESCRIPTION	JIRA TICKETS
SDC	<p><b>PNF PACKAGE FORMAT</b>                      Identify current VNF package format constraints in SDC                      Propose a PNF Package format                      Evaluate VNF and PNF package alignment</p> <p><b>PACKAGE MAPPING</b> - Onboarding PNF package to internal PNF package mapping</p> <p><b>PNFD MAPPING</b> - Onboarding PNFD to internal PNFD mapping                      A new flow to map ETSI SOL001 PNFD in SDC AID model.</p> <p><b>ARTIFACT MANAGEMENT</b>                      Design-time catalog update to associate artifacts to a PNF                      Run-time catalog update to associate artifacts to a PNF</p>	<p><a href="#">SDC-1970</a>, <a href="#">SDC-1973</a>, <a href="#">SDC-1974</a>,  <a href="#">SDC-1975</a>, <a href="#">SDC-1976</a>, <a href="#">SDC-1977</a>,  <a href="#">SDC-1978</a>, <a href="#">SDC-1979</a>, <a href="#">SDC-1980</a></p>
VNF SDK	<p><b>PACKAGE VERIFICATION</b> - PNF package format verification</p> <p><b>PNF PACKAGE FORMAT</b></p> <p><b>PACKAGE USAGE</b> - Package for PNF Onboarding Package for use in VNF SDK</p>	<p><a href="#">VNFSDK-337</a>, <a href="#">VNFSDK-338</a>,  <a href="#">VNFSDK-339</a>, <a href="#">VNFSDK-340</a>,  <a href="#">VNFSDK-341</a>, <a href="#">VNFSDK-342</a>,  <a href="#">VNFSDK-343</a></p>
Modelling	<p><b>PNFD MAPPING</b> – Mapping Onboarded PNFD to platform PNFD mapping                      SDC SW task but PNFD mapping &amp; part of ONAP Resource Data Model.</p>	
VNF Requirements	<p><b>PACKAGE, DESCRIPTOR, ARTIFACTS</b> - VNF requirements to cover PNF package contents and directory structures and mandatory elements.</p> <p><b>PNF DESCRIPTOR</b> - Requirements for the PNF Descriptor</p> <p><b>ARTIFACTS</b> - Requirements for Artifacts of PNF and PNF Package</p>	<p><a href="#">VNFQTS-506</a>, <a href="#">VNFQTS-496</a>,  <a href="#">VNFQTS-497</a>, <a href="#">VNFQTS-498</a>,  <a href="#">VNFQTS-499</a>, <a href="#">VNFQTS-505</a>,  <a href="#">VNFQTS-507</a>, <a href="#">VNFQTS-508</a></p>
RT Comp	<p>Grant backward compatibility use cases on ONAP RT Components</p>	



HealthVF

⚠ V1.0

CERTIFIED

Switch to the latest version

Upgrade Services





- General
- Deployment Artifact**
- Information Artifact
- TOSCA Artifacts
- Composition
- Operation
- Activity Log
- Deployment
- Properties Assignment

## Deployment Artifact

Name	Type	Deployment timeout	Version	UUID	
VF License	VF_LICENSE		1	0e724709-4382-4dab-a824-581488f5f6fd	↓
base_health	HEAT	60	2	a89ce4c4-c81e-45d2-800c-3b67bd888225	↓
VF HEAT ENV	HEAT_ENV		0		↓
Vendor License	<u>VENDOR_LICENSE</u>		1	abe0861c-994b-4018-929a-5a0c7039139d	↓ Magnifier
healthcheck_server_config	<u>HEAT_ARTIFACT</u>		1	de22a326-928c-4fae-9f46-8a5474898af3	↓ Magnifier

# PNF PACKAGE CREATION & DELIVERY



- Onboarding Package 
- Onboarding 
- Vendor 

# PNF ONBOARDING PACKAGE



Definition Files

PNF Package Artifacts

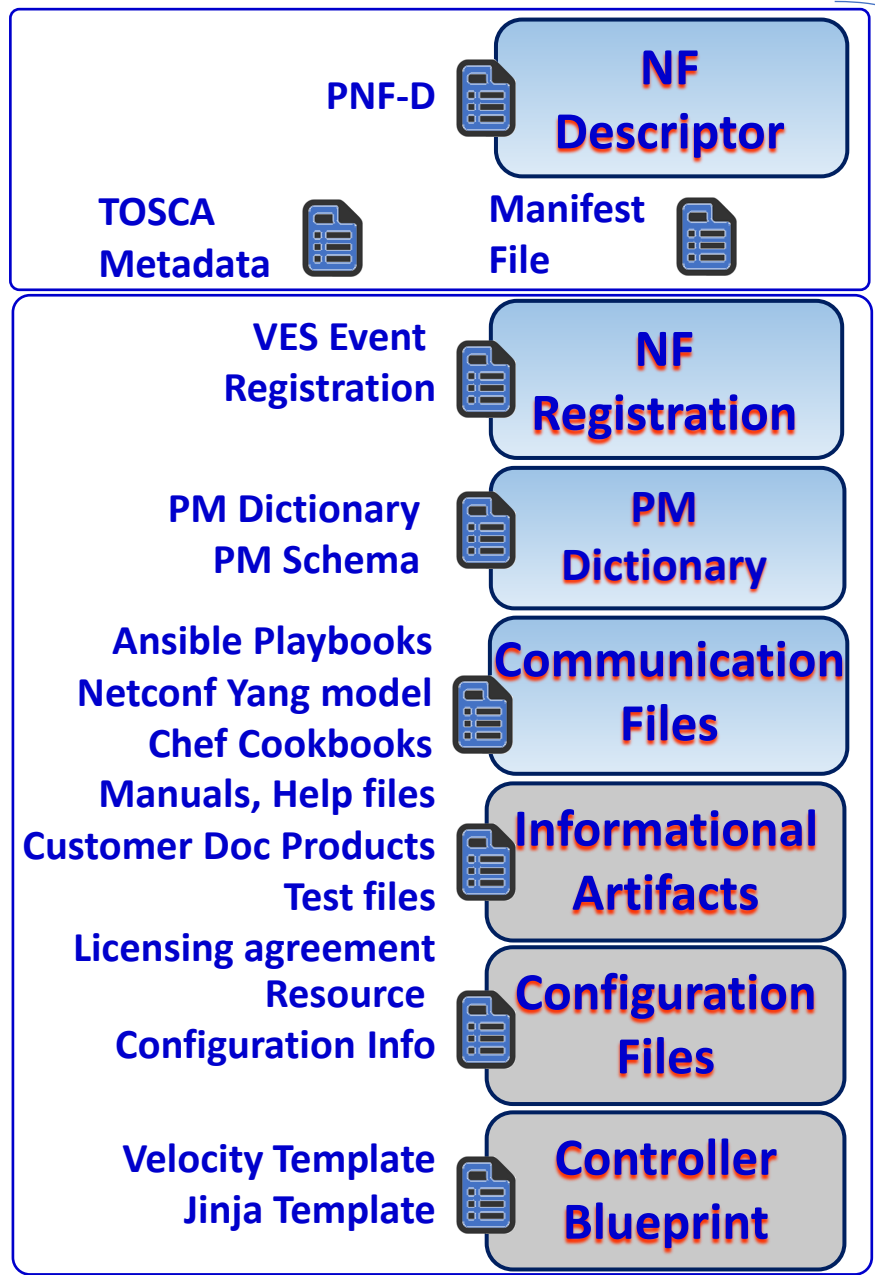

Vendor Provided

## PNF Onboarding Package

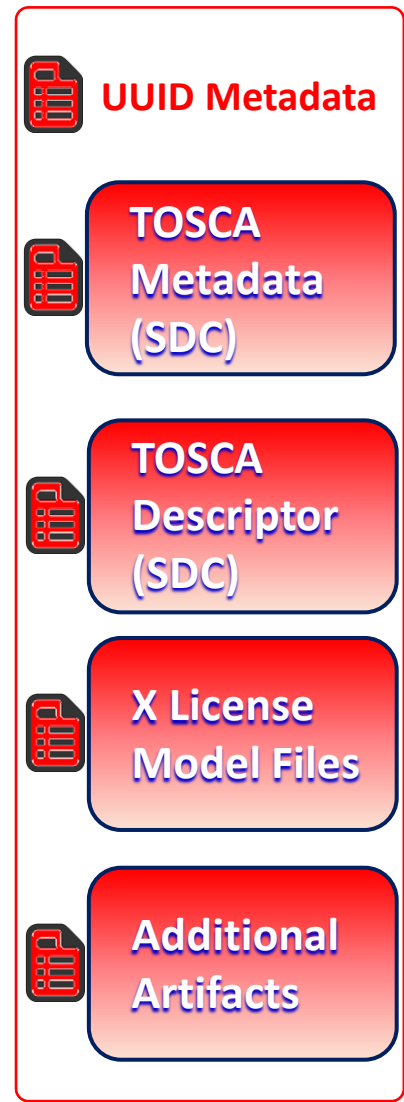

SDC Added Files

SDC Service CSAR Package



SDC Design Time

Controller Blueprint Archive file (manually in R4 only manual, or incorporated into a package? [FUTURE])

Jinja (Python-based dynamic content) Template

Velocity Template

Schema vendor specific/agnostic

Generic or Per PNF type (customized)

# VNF (TOSCA format) ONBOARDING PACKAGE



Definition Files

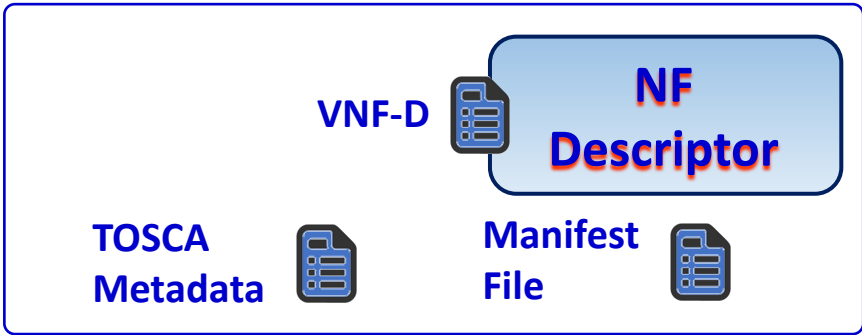

VNF Package Artifacts (not SOL004 based)

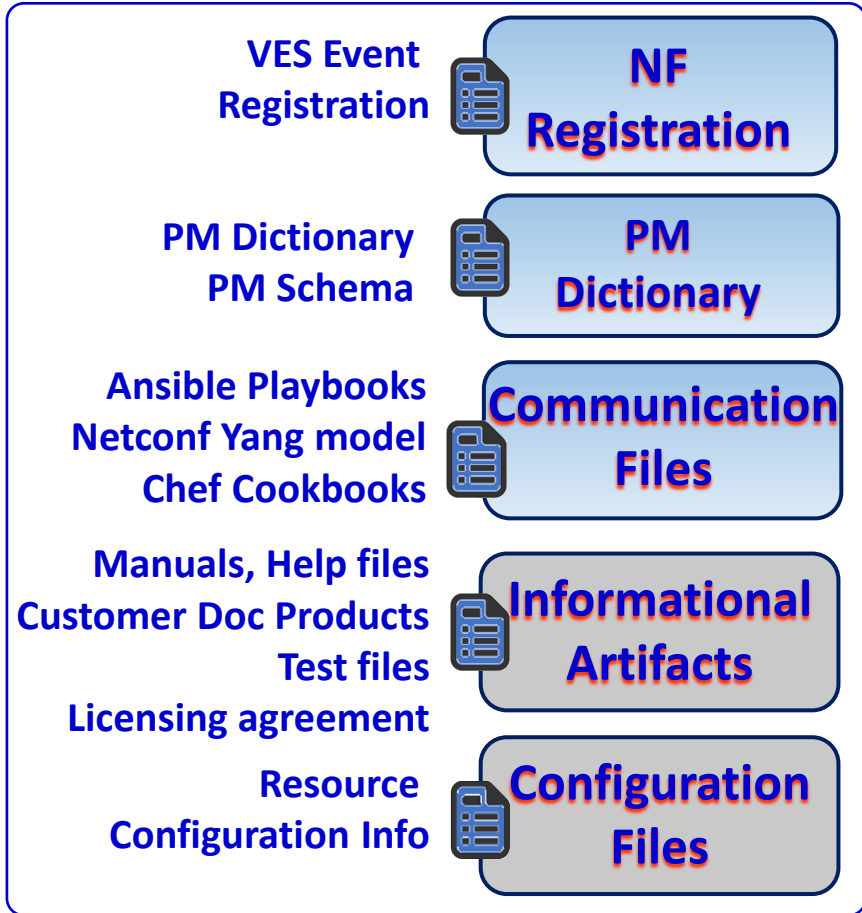

Vendor Provided

## VNF Onboarding Package



SDC Added Files

SDC Service CSAR Package





SDC Design Time

# VNF (HEAT Template) ONBOARDING PACKAGE





Definition Files

#x HEAT Template  **Heat Template**

Environment file  **Proprietary Manifest File** 

PNF Package Artifacts

VES Event Registration  **NF Registration**

PM Dictionary PM Schema  **PM Dictionary**

Ansible Playbooks  
Netconf Yang model  
Chef Cookbooks  **Communication Files**

Manuals, Help files  
Customer Doc Products  **Informational Artifacts**

Test files  
Licensing agreement  
Resource Configuration Info  **Configuration Files**

Vendor Provided

## VNF Onboarding Package



 **UUID Metadata**

 **AID Model (SDC)**

 **X License Model Files**

 **Additional Artifacts**

SDC Added Files

SDC Service CSAR Package



SDC Design Time

VERIFY WITH SDC TEAM

# SDC INTERNAL PACKAGE



## SDC Internal Package

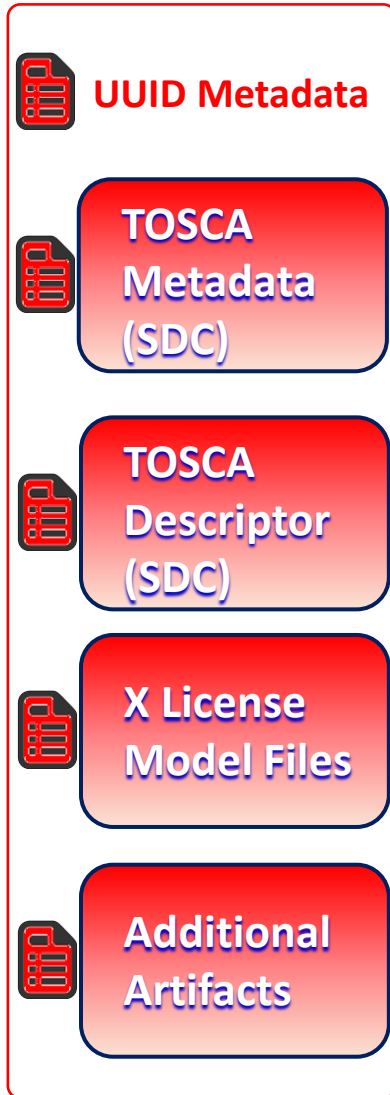

**SDC Added Files**

**SDC  
Service  
CSAR  
Package**



**SDC  
Design  
Time**

SDC Additions

SDC Internal PNF Package Artifacts

# R4: Modelling VES Events

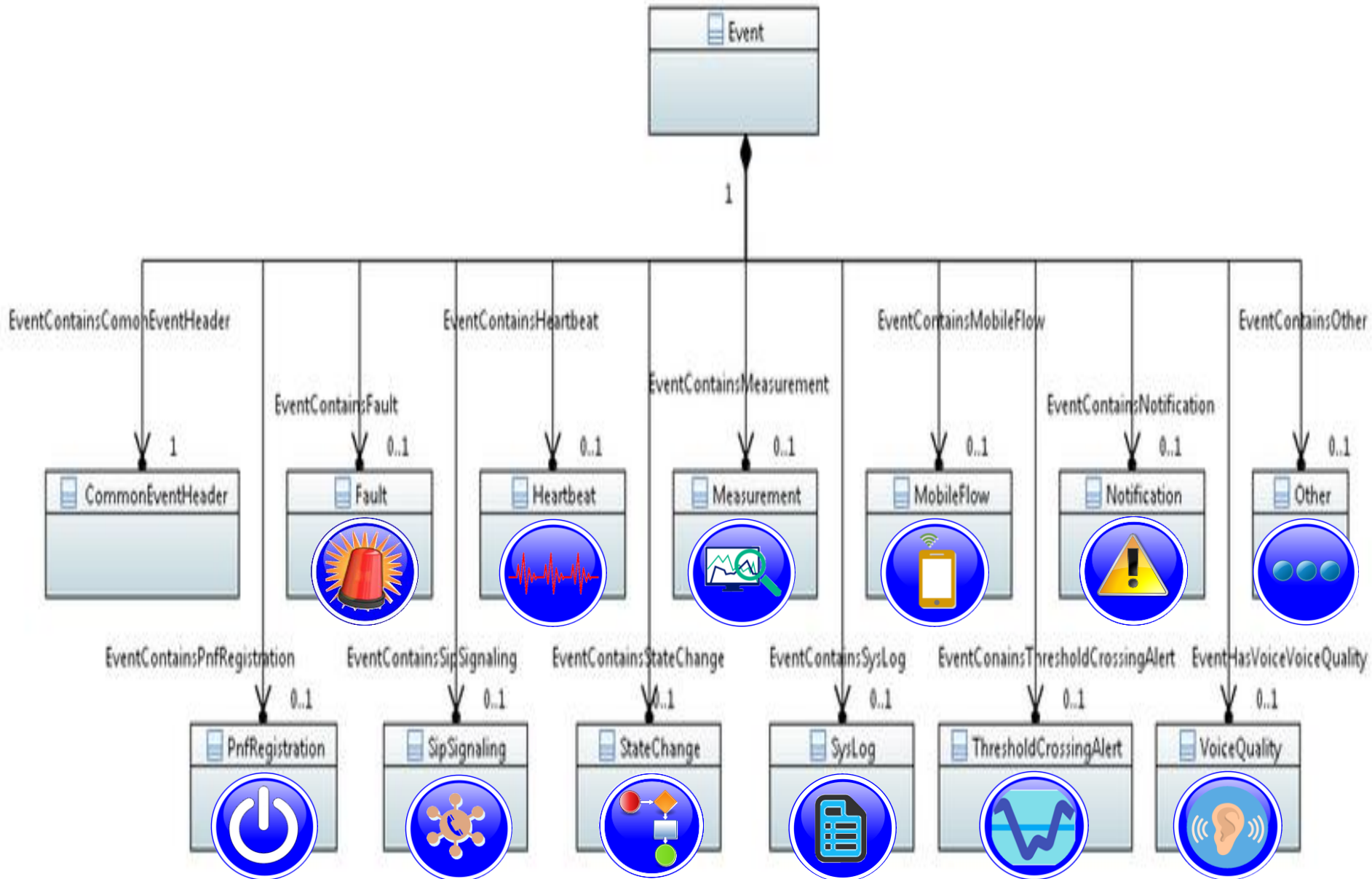



# SDK VALIDATION - PNF ONBOARDING PACKAGE



**5** ETSI SOL004 Validation for Meta-Data file (*TOSCA.meta*) in PNF Package. New checks for "Entry definition, Entry-manifest, Entry-change-log, Entry-tests, Entry-certificates" is VNF SDK development work.

**4** VNF SDK to check the PNF keywords in the MainServiceTemplate.mf (manifest) New tags are pnf\_product\_name and pnf\_provider\_id, pnf\_package\_version, pnf\_release\_date\_time and non\_mano\_artifact\_sets.

**1** VNF-SDK Checks that files defined in the Manifest file (specify files & directory locations) actually exist where they have been specified in the Manifest File.

**2** License File Check  
This is a license term file

**3** Certificate File Check

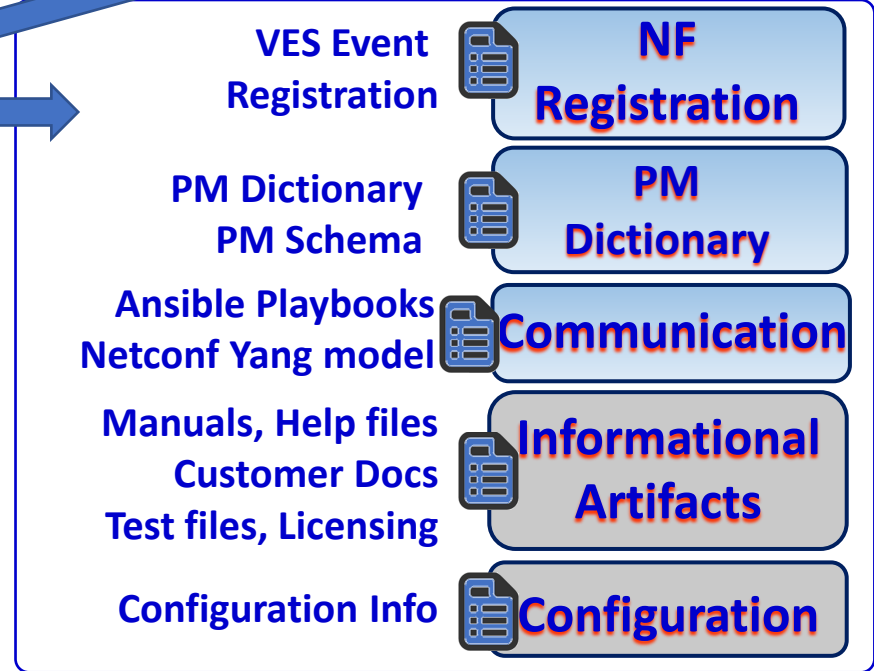
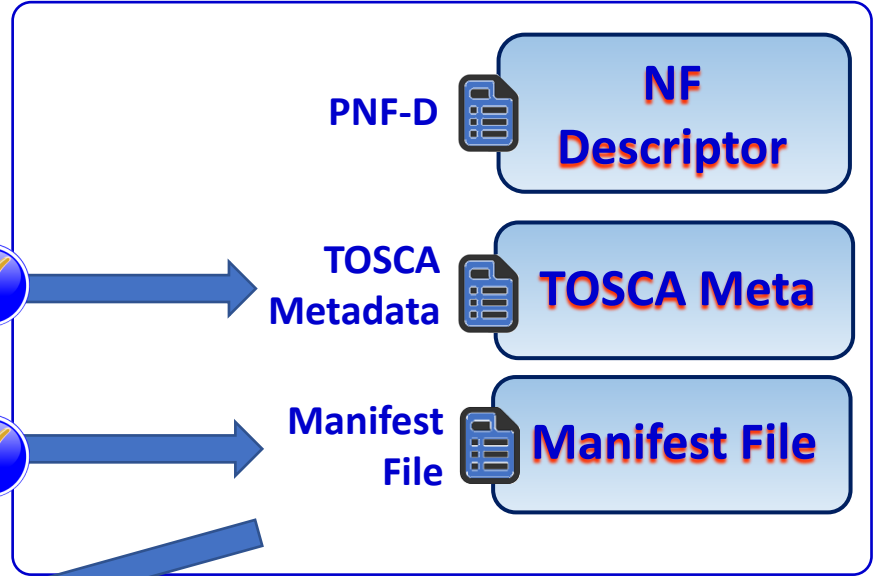

Definition Files

PNF Package Artifacts

# SDK VALIDATION - PNF ONBOARDING PACKAGE



Definition Files

PNF Package Artifacts

6 ETSI SOL004 Validation for **Meta-Data file (TOSCA.meta)** in PNF Package. VNF-SDK checks for *Entry definition, Entry-manifest, Entry-change-log, Entry-tests, and Entry-certificates*

5 VNF SDK checks PNF keywords in the **MainServiceTemplate.mf (manifest)** Tags: *pnf\_product\_name, and pnf\_provider\_id, pnf\_package\_version, pnf\_release\_date\_time, and non\_mano\_artifact\_sets.*

4 VNF-SDK checks **files & directory** locations defined in the Manifest file actually exist.

2 **License File** Check  
This is a license term file

3 **Certificate File** Check

PNF-D  
**NF Descriptor**

TOSCA Metadata  
**TOSCA Meta**

Manifest File  
**Manifest File**

VES Event Registration  
**NF Registration**

PM Dictionary  
PM Schema  
**PM Dictionary**

Ansible Playbooks  
Netconf Yang model  
**Communication**

Manuals, Help files  
Customer Docs  
Test files, Licensing  
**Informational Artifacts**

Configuration Info  
**Configuration**

Vendor Provided – PNF Onboarding Package

# PNF PACKAGES

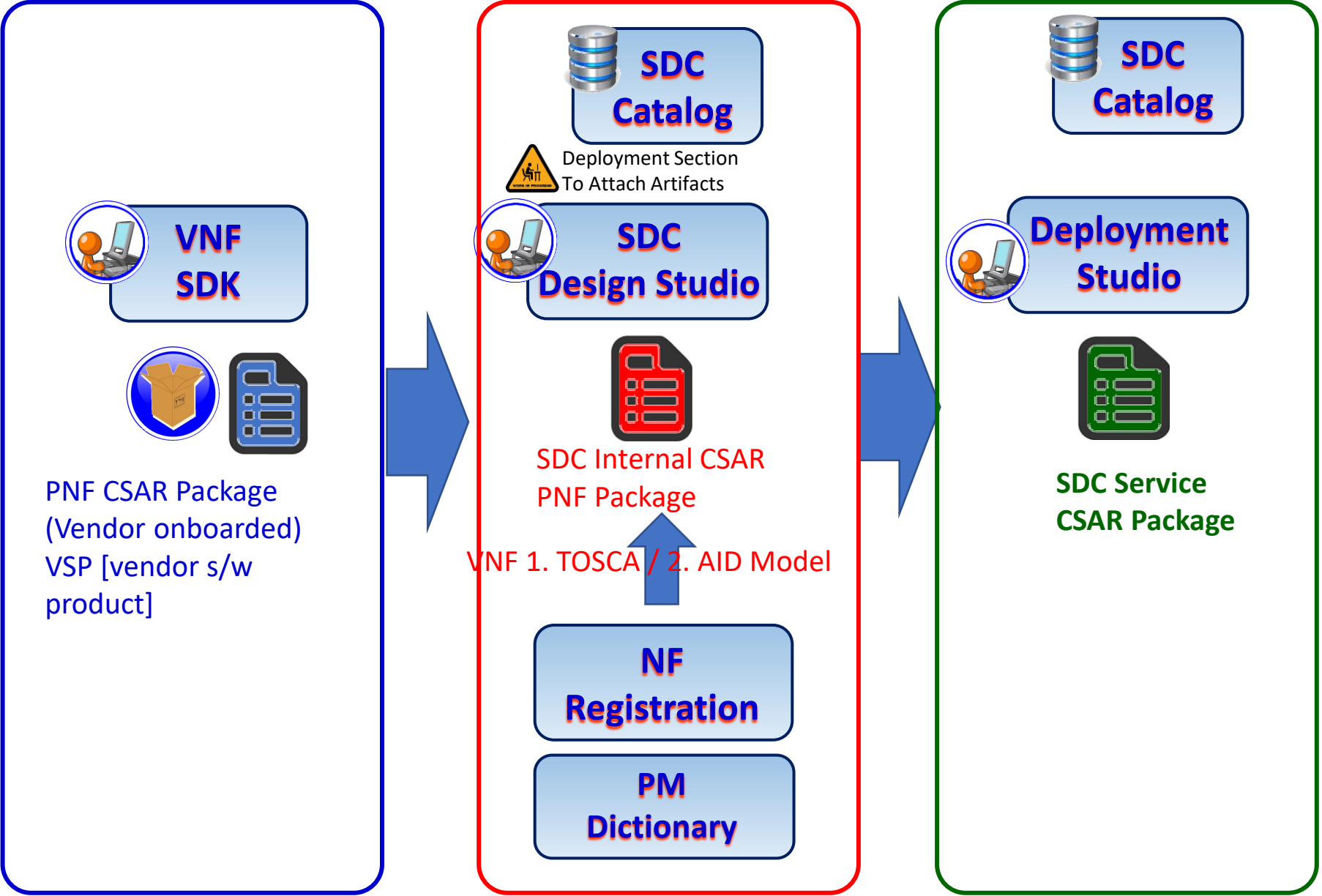

# PNF PACKAGES



**VNF  
SDK**



PNF Package  
(Vendor onboarded)  
VSP [vendor s/w  
product]

**PNF Onboarding (CSAR file)**

**Note:**

- Package Example
- Not all files are listed.
- Folder / file name in blue is requested by SOLO4.
- Folder / file name in black is example only.

TOSCA-Meta-Version: 1.0  
CSAR-Version: 1.1  
CreatedBy: Ericsson (Du Quang 2018-12-03)  
Entry-Definitions: Definitions/DefinitionsTemplate.yml  
Entry-Interfaces: MainServiceTemplate.mf  
Entry-Change-Log: Artifacts/ChangeLog.txt  
Entry-Terms: Artifacts/Terms  
Entry-Certificate: Artifacts/Certificate.yml

TOSCA-Meta-Version: 1.0  
CSAR-Version: 1.1  
CreatedBy: Ericsson (Du Quang 2018-12-03)  
Entry-Definitions: Definitions/DefinitionsTemplate.yml  
Entry-Interfaces: MainServiceTemplate.mf  
Entry-Change-Log: Artifacts/ChangeLog.txt  
Entry-Terms: Artifacts/Terms  
Entry-Certificate: Artifacts/Certificate.yml

**ROOT**

- TOSCA-Metadata
- Definitions
- Artifacts
- MainServiceTemplate.mf

**TOSCA.meta** (NF descriptor)

**MainServiceTemplate.yml** (Not supported by ONAP Casablanca)

**images**

- Configuration (yang-module.yang)
- Yaml module (yang-module.yang)
- Measurements
- Events
- Tests
- ChangeLog.txt
- MainServiceTemplate.yml
- License\_term.txt
- Install.ch

**Not used yet**



**SDC  
Catalog**



**SDC  
Design Studio**



**SDC Internal CSAR  
PNF Package**

**CSAR file**

**ROOT**

- TOSCA-Metadata
- Definitions
- Artifacts
- CSAR.meta

TOSCA-Meta-Version: 1.0  
CSAR-Version: 1.1  
CreatedBy: Ericsson (Du Quang 2018-12-03)  
Entry-Definitions: Definitions/DefinitionsTemplate.yml  
Entry-Interfaces: MainServiceTemplate.mf  
Entry-Change-Log: Artifacts/ChangeLog.txt  
Entry-Terms: Artifacts/Terms  
Entry-Certificate: Artifacts/Certificate.yml

**Annotations**

- artifacts.yml
- capabilities.yml
- data.yml
- groups.yml
- interfaces.yml
- nodes.yml
- relationships.yml
- resource-ZNF-template.yml
- resource-ZNF-template-interface.yml

**Deployment**

- Deployment
- Informational
- Other
- PNF\_ONBOARDED\_PACKAGE



**SDC  
Catalog**



**Deployment  
Studio**



**SDC Service  
CSAR Package**

**CSAR file**

**ROOT**

- TOSCA-Metadata
- Definitions
- Artifacts
- MainServiceTemplate.mf

TOSCA-Meta-Version: 1.0  
CSAR-Version: 1.1  
CreatedBy: Ericsson (Du Quang 2018-12-03)  
Entry-Definitions: Definitions/DefinitionsTemplate.yml  
Entry-Interfaces: MainServiceTemplate.mf  
Entry-Change-Log: Artifacts/ChangeLog.txt  
Entry-Terms: Artifacts/Terms  
Entry-Certificate: Artifacts/Certificate.yml

**Annotations**

- artifacts.yml
- capabilities.yml
- data.yml
- groups.yml
- interfaces.yml
- nodes.yml
- relationships.yml
- resource-ZNF-template.yml
- resource-ZNF-template-interface.yml

**Deployment**

- Deployment
- Informational
- Other
- PNF\_ONBOARDED\_PACKAGE

# PNF Onboarding Package (CSAR)



## PNF Onboarding (CSAR file)

### Note:

- Package Example
- Not all files are listed.
- Folder / file name in blue is requested by SOL004.
- Folder / file name in black is example only.

TOSCA-Meta-Version: 1.0  
CSAR-Version: 1.1  
Created-By: Ericsson (Zu Qiang 2018-12-03)  
Entry-Definitions:  
Definitions/MainServiceTemplate.yaml  
Entry-Manifest: MainServiceTemplate.mf  
Entry-Change-Log: Artifacts/ChangLog.txt  
Entry-Tests: Artifacts/Tests  
Entry-Certificate: Artifacts/License\_term.txt

### ROOT

- TOSCA-Metadata
- Definitions
- Artifacts
- MainServiceTemplate.mf

TOSCA.meta

NF descriptor

MainServiceTemplate.yaml

Not supported by ONAP Casablanca

Images

Deployment

Scripts

Tests

ChangeLog.txt

MainServiceTemplate.cert

License\_term.txt

Not used yet

Configuration

Yang\_module

Measurements

Events

...

yang-module.yang

pm-dictionary.yaml

ves-dictionary.yaml

Install.csh

...

### metadata:

pnf\_product\_name: gNB  
pnf\_provider\_id: Ericsson  
pnf\_package\_version:1.0  
pnf\_release\_date\_time:2018-12-03T08:44:00-05:00  
non\_mano\_artifact\_sets:  
Events:  
source:  
Artifacts/Deployment/Events/VES\_registration.yaml

# SOL004 required PNF manifest file



## PNF ONBOARDING FILES – Manifest file Example



```
metadata:                                     ##### New key Name to be supported by SDC
pnf_product_name: gNB
pnf_provider_id: Ericsson
pnf_package_version:1.0
pnf_release_date_time:2018-12-03T08:44:00-05:00

##### non mano artifact sets to be supported by SDC
non_mano_artifact_sets:
Events:
    source: Artifacts/Deployment/Events/VES_registration.yaml
Measurements:
    source: Artifacts/Deployment/Measurements/PM_Dictionary.yaml
Yang_module:
    Source: Artifacts/Deployment/Yang_module/Yang_module.yaml
Others:
    Source: Artifacts/Informational/scripts/install.sh
    Source: Artifacts/Informational/user_guide.txt
    Source: Artifacts/Other/installation_guide.txt
    Source: Artifacts/Other/review_log.txt
```

# VNFSDK #4 Manifest file: new PNF tags



## PNF ONBOARDING FILES – Main Service Template manifest (.mf) file

VNF SDK to check the PNF keywords in the MainServiceTemplate.mf  
New tags are  
pnf\_product\_name and  
pnf\_provider\_id,  
pnf\_package\_version,  
pnf\_release\_date\_time  
and  
non\_mano\_artifact\_sets.

metadata:

**pnf\_product\_name:** gNB

**pnf\_provider\_id:** CompanyXYZ

**pnf\_package\_version:** 1.0

**pnf\_release\_date\_time:** 2019-02-11T09:10:00-05:00

**non\_mano\_artifact\_sets:**

Events:

source: Artifacts/Deployment/Events/VES\_registration.yaml

Measurements:

source:

Artifacts/Deployment/Measurements/PM\_Dictionary.yaml

Yang\_module:

Source:

Artifacts/Deployment/Yang\_module/Yang\_module.yaml

Others:

Source: Artifacts/Informational/scripts/install.sh

Source: Artifacts/Informational/user\_guide.txt

Source: Artifacts/Other/installation\_guide.txt

Source: Artifacts/Other/review\_log.txt



## PNF ONBOARDING FILES – Tosca Metadata File



TOSCA-Meta-File-Version: 1.0



CSAR-Version: 1.1



Created-By: Ericsson



Entry-Definitions: Definitions/resource-Ericssongnodeb-template.yml



Entry-Manifest: resource-Ericssongnodeb-template.mf



Entry-Certificate: Artifacts/resource-Ericssongnodeb-template.cert



Entry-Tests: Artifacts/Tests

Entry-Licenses: Artifacts/Licenses/license\_term.txt

Entry-Change-Log: Artifacts/ChangeLog.txt



# VNFSDK Task #5 TOSCA Meta file checks



## PNF ONBOARDING FILES – TOSCA Meta File Checks

"*TOSCA-Meta-Version*" and "*CSAR-Version*" and "*Created by*" checks are already supported.

ETSI SOL004 Validation for Meta-Data file & Manufacturer file (***TOSCA.meta*** file) in PNF Package. New checks for "*Entry definition, Entry-manifest, Entry-change-log, Entry-tests, Entry-certificates*" would be new VNF SDK development work.

**TOSCA-Meta-Version:** 1.0  
**CSAR-Version:** 1.1  
**Created-By:** CompanyXYZ (User123 2019-02-11)

**Entry-Definitions:** Definitions/MainServiceTemplate.yaml  
**Entry-Manifest:** MainServiceTemplate.mf  
**Entry-Change-Log:** Artifacts/ChangLog.txt  
**Entry-Tests:** Artifacts/Tests  
**Entry-Certificate:** Artifacts/License\_term.txt

# SDC Service CSAR Package



CSAR file

Directory list under review

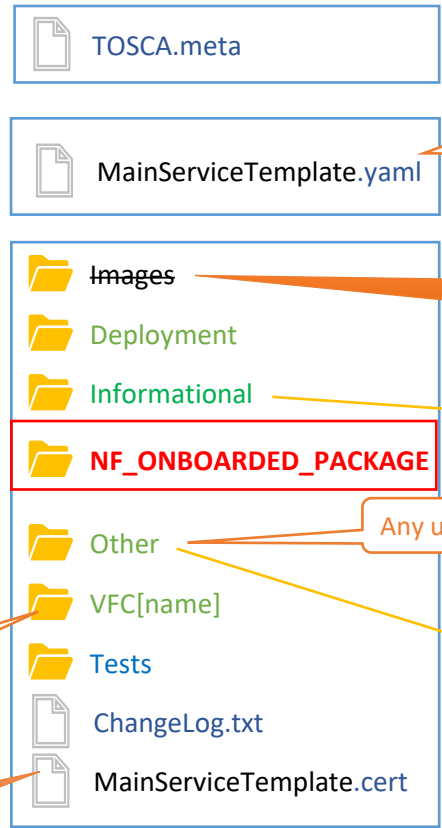
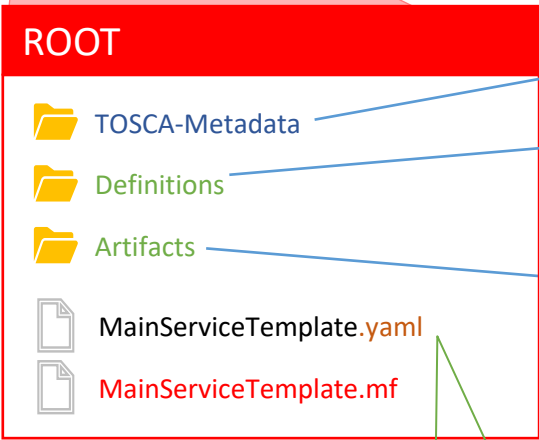

NF descriptor created by SDC

Not supported by ONAP Casablanca

Any unrecognized artifacts

Copy of NF descriptor

Directory list under review

VFC[name]/Deployment  
VFC[name]/Information  
(can we move it in Deployment dir ?)

Not supported by ONAP Casablanca

- HEAT
- HEAT\_VOL
- HEAT\_NET
- HEAT\_ENV
- HEAT\_ARTIFACT
- HEAT\_NESTED
- YANG\_XML
- MODEL\_INVENTORY\_PROFILE
- VNF\_CATALOG
- VNF\_LICENSE
- VENDOR\_LICENSE
- APPC\_CONFIG
- VF\_MODULES\_METADATA
- DCAE\_TOSCA
- DCAE\_JSON
- PLAN

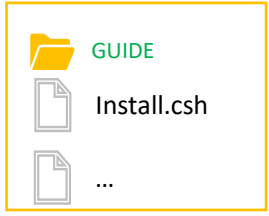

SDC adds files  
 SDC add vendor meta-data  
 Internal CSAR file  
 Structure change  
 Information missing  
 Metadata file changed (generated by SDC) not have info on left side  
 Manufactured metafile is lost  
 Certain artifacts is lost.  
 CSAR.meta (added by SDC) ... what is it for?  
 Definition File (define policies) added by SDC  
 Resource UUID  
 WHAT WOULD BE A PROBLEM  
 WHAT DOES THE VENDOR NEEDS TO PROVIDE  
 WHAT DOES SDC need  
 Today in PNF descriptor more than 3 properties  
 In SDC PNF CSAR only 3 properties NF function, NF role, NF type, SWVersions  
 PNF onboarding package from SOL001 MANY properties  
 ARTIFACTS SOL004 MANY artifacts add  
 In Current PNF CSAR file no place to hold it.

Heat File  
 OPENO TOSCA

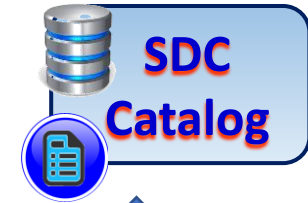

PNF Package Version 2019-1.1



Resource CSAR File (PNF)  
 onboarded

Vendor provided



PNF  
 Onboarding  
 (CSAR file)

Note:

- Package Example
- Not all files are listed.
- Folder / file name in blue is requested by SOL004.
- Folder / file name in black is example only.

TOSCA-Meta-Version: 1.0  
 CSAR-Version: 1.1  
 Created-By: Ericsson (Zu Qiang 2018-12-03)  
 Entry-Definitions: Definitions/MainServiceTemplate.yaml  
 Entry-Manifest: MainServiceTemplate.mf  
 Entry-Change-Log: Artifacts/ChangLog.txt  
 Entry-Tests: Artifacts/Tests  
 Entry-Certificate: Artifacts/License\_term.txt

ROOT

- TOSCA-Metadata
- Definitions
- Artifacts
- MainServiceTemplate.mf

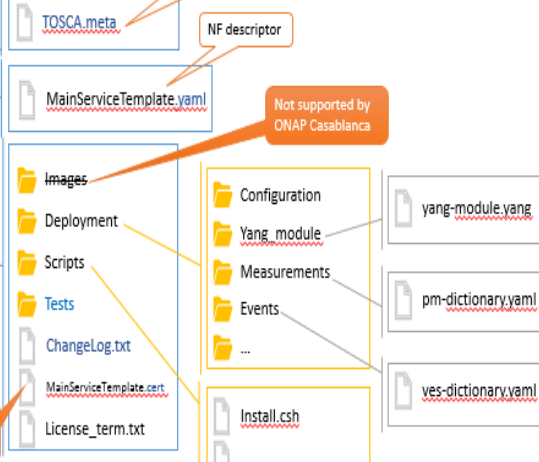

metadata:  
 pnf\_product\_name: s118  
 pnf\_provider\_id: Ericsson  
 pnf\_package\_version: 1.0  
 pnf\_release\_date\_time: 2018-12-08T08:44:00-05:00  
 non\_memo\_artifact\_sets:  
 Events:  
 source:  
 Artifacts/Deployment/Events/ES\_registration.yaml

Not used yet

SDC

CSAR file

ROOT

- TOSCA-Metadata
- Definitions
- Artifacts
- csar.meta

TOSCA-Meta-File-Version: 1.0  
 CSAR-Version: 1.1  
 Created-By: Carlos Santana  
 Entry-Definitions: Definitions/resource-ZPnf1-template.yaml  
 Name: csar.meta  
 Content-Type: text/plain

SDC-TOSCA-Meta-File-Version: 1.0  
 SDC-TOSCA-Definitions-Version: 9.0

- Deployment
- Informational
- Other
- PNF\_ONBOARDED\_PACKAGE

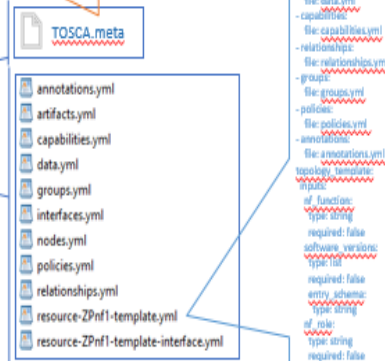

```
tosca_definitions_version: tosa_simple_yaml_1_1
metadata:
  irvariantUUID: 3f244798-e083-41af-915c-908663da4634
  UUID: 2310095-584a-466a-8012-4243ced4076
name: Z_PNF_1
descriptions: Z_PNF_1
type: PNF
category: Application L4+
subcategory: Application Server
resourceVendor: Ericsson
resourceUUID: Release: "1.0"
resourceVersion: "1.0"
resourceVersionNumber: ""
imports:
  - nodes:
    - file: nodes.yaml
    - datatype: ""
    - file: data.yaml
    - capabilities:
    - capabilities.yaml
    - relationships:
    - relationships.yaml
    - groups:
    - groups.yaml
    - policies:
    - policies.yaml
    - annotations:
    - annotations.yaml
    topology_templates:
    of function:
      required: false
      software_versions:
      type: string
      required: false
      entry_schema:
      type: string
      of role:
      type: string
      required: false
      of type:
      type: string
      required: false
      subscription_macro_refs:
      UUID: ""
      type: string
      resource: pnf_ZPnf1
      type: string
```



Resource CSAR File (VF)  
generated from VSP



Resource CSAR File (VF)  
generated from VSP

NF Descriptor  
Descriptor (Interface connections)  
Artifacts (incl. Onboarded Package)

- resource-Zu Servicemodel-template.yml
  - resource-Zu Servicemodel-template-interface.yml
  - org.openecomp.resource.vf.Zu Servicemodel\_v1.0
- 
- resource-Zu Servicemodel-template.yml
  - resource-Zu Servicemodel-template-interface.yml
  - org.openecomp.resource.vf.Zu Servicemodel\_v1.0

SDC Service Package Version 1.5



SDC Service  
CSAR File

(SDC distributes to  
other ONAP RT  
components)

PNF Package Version 2019-1.1



Resource CSAR File (PNF)  
onboarded (SDC)



Resource CSAR File (PNF)  
onboarded (SDC)



Resource CSAR File (PNF)  
onboarded (SDC)

SDC PNF Package Version 2.6

- resource-Zu Servicemodel-template.yml
  - resource-Zu Servicemodel-template-interface.yml
  - org.openecomp.resource.vf.Zu Servicemodel\_v1.0
- 
- resource-Zu Servicemodel-template.yml
  - resource-Zu Servicemodel-template-interface.yml
  - org.openecomp.resource.vf.Zu Servicemodel\_v1.0
- 
- resource-Zu Servicemodel-template.yml
  - resource-Zu Servicemodel-template-interface.yml
  - org.openecomp.resource.vf.Zu Servicemodel\_v1.0

SDC doesn't recognize SOL001 Modeling vs Platform Data Model  
SOL004 artifacts some artifacts dropped by SDC  
name NF (naming policy)

TOSCA API to ingest CSAR package > same APIs to have clients ingest PNFs > onboarding of PNF packages.

NETWORK ASSIGNMENTS VLAN tag assignment,, IP assignments > Plug & play

# Onboarded Package to SDC Internal Mapping

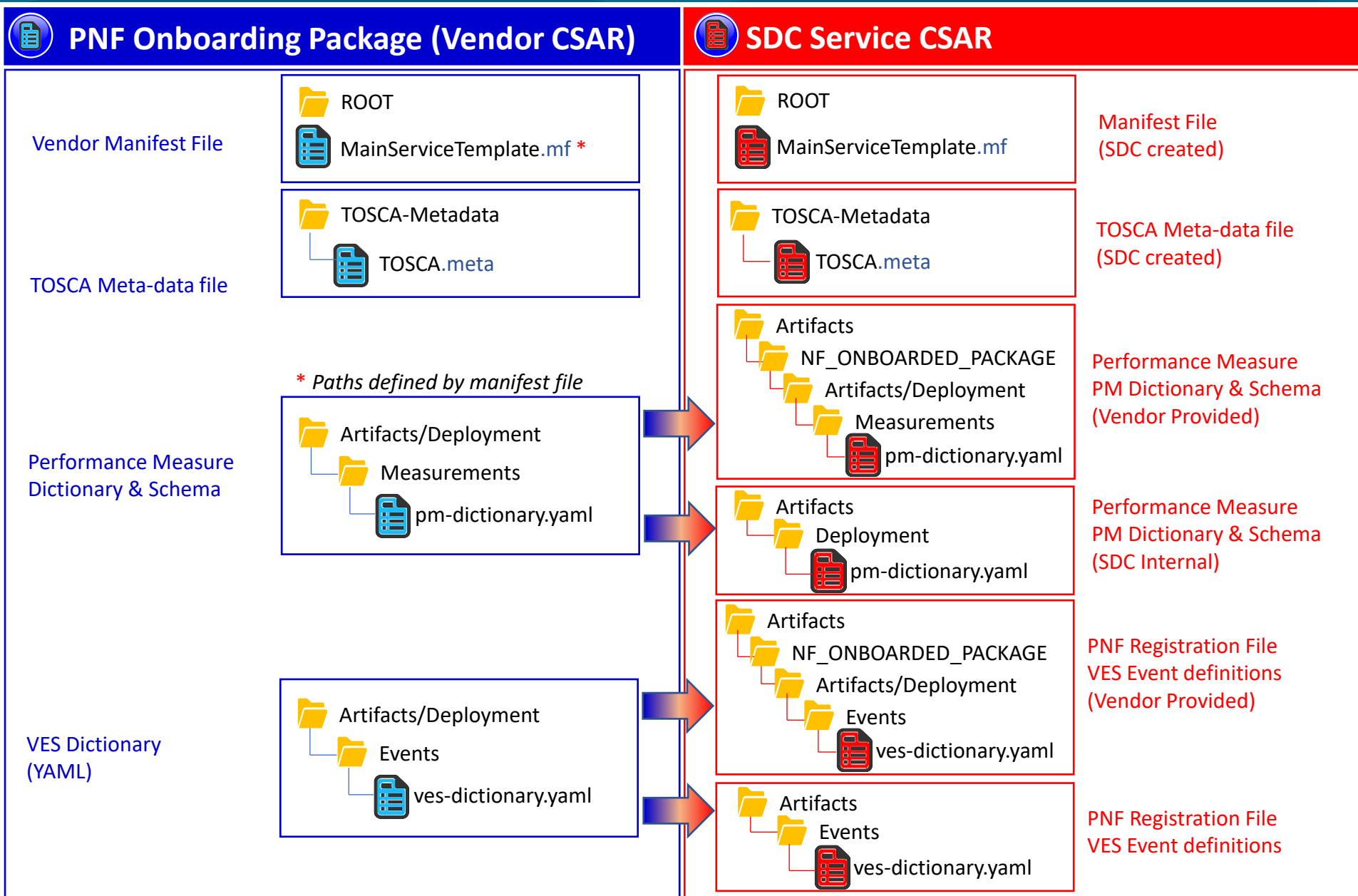

## PRE-ONBOARDING PROCESSES

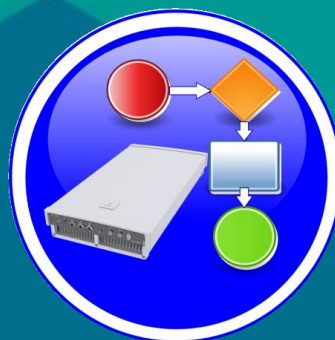

## ONBOARDING PROCESSES



NF Descriptor	
Pre Onboarding	
Asset Manager	
Platform Model	
Onboarding	
Asset Manager	

# PRE-ONBOARDING: VNF SDK DEVELOPMENT



PNF-D

 **NF Descriptor**

VES Event Registration Specification

 **NF Registration**

PM Dictionary  
PM Schema

 **PM Dictionary  
PM Schema**

Manuals, Help files  
CustDoc Products  
Test files

**Informational Artifacts**

Licensing agreement

Configuration Info

**Configuration Files**

Ansible Playbooks  
Netconf Yang model  
Chef Cookbooks

**Communication Files**



**2 PNF Pre-Onboarding** (optional): VNF-SDK (  ) can create or validate PNF Onboarding Package

 **VNF SDK**

**Package creation**

WinZIP  
Validating Content



**PNF Onboarding Package**

# PNF ONBOARDING: SDC Catalog

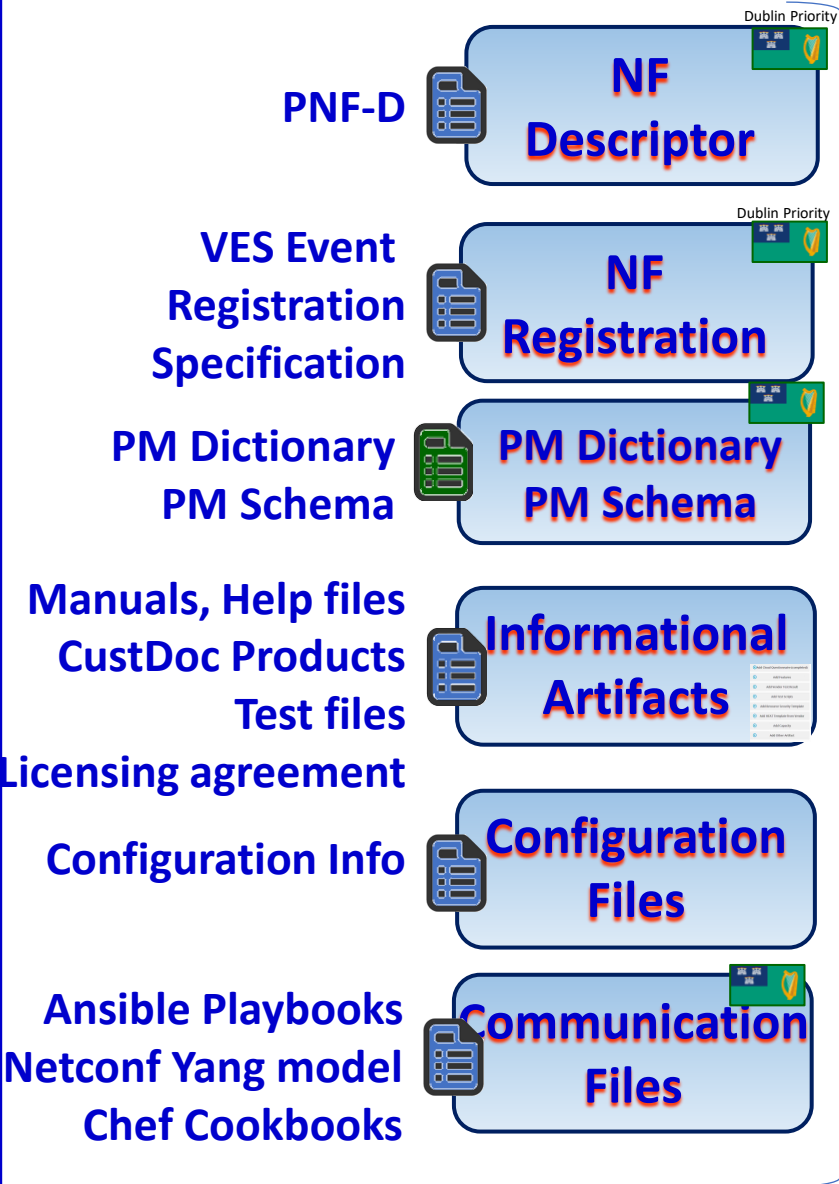

   **3 PNF Onboarding:** PNF Package is loaded

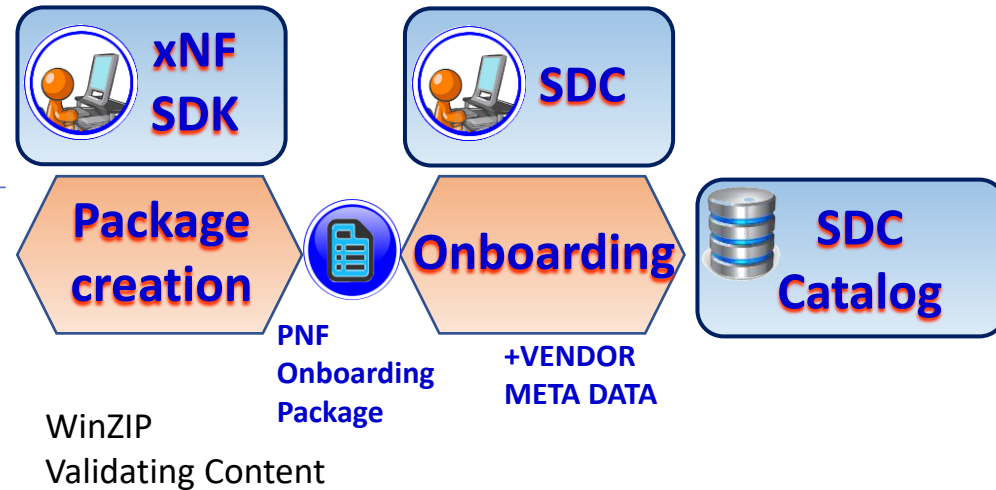



# xNF ONBOARDING Dependencies R3



Pre-onboarding



Onboarding Design Time



SDC

SO

SDNC/APPC  
Multi-VIM

VFC

VNF SDK

Vendor  
VNF CSAR

VNFD ETSI SOL001 based

VNF  
SOL001

VOLTE workflow

Heat template

VNF heat  
template

vCPE CreateVcpeWorkflow

TOSCA  
AID VNF

PNF  
defined by  
UI

vCPE Create&ActivateWorkflow

TOSCA  
AID PNF

AID

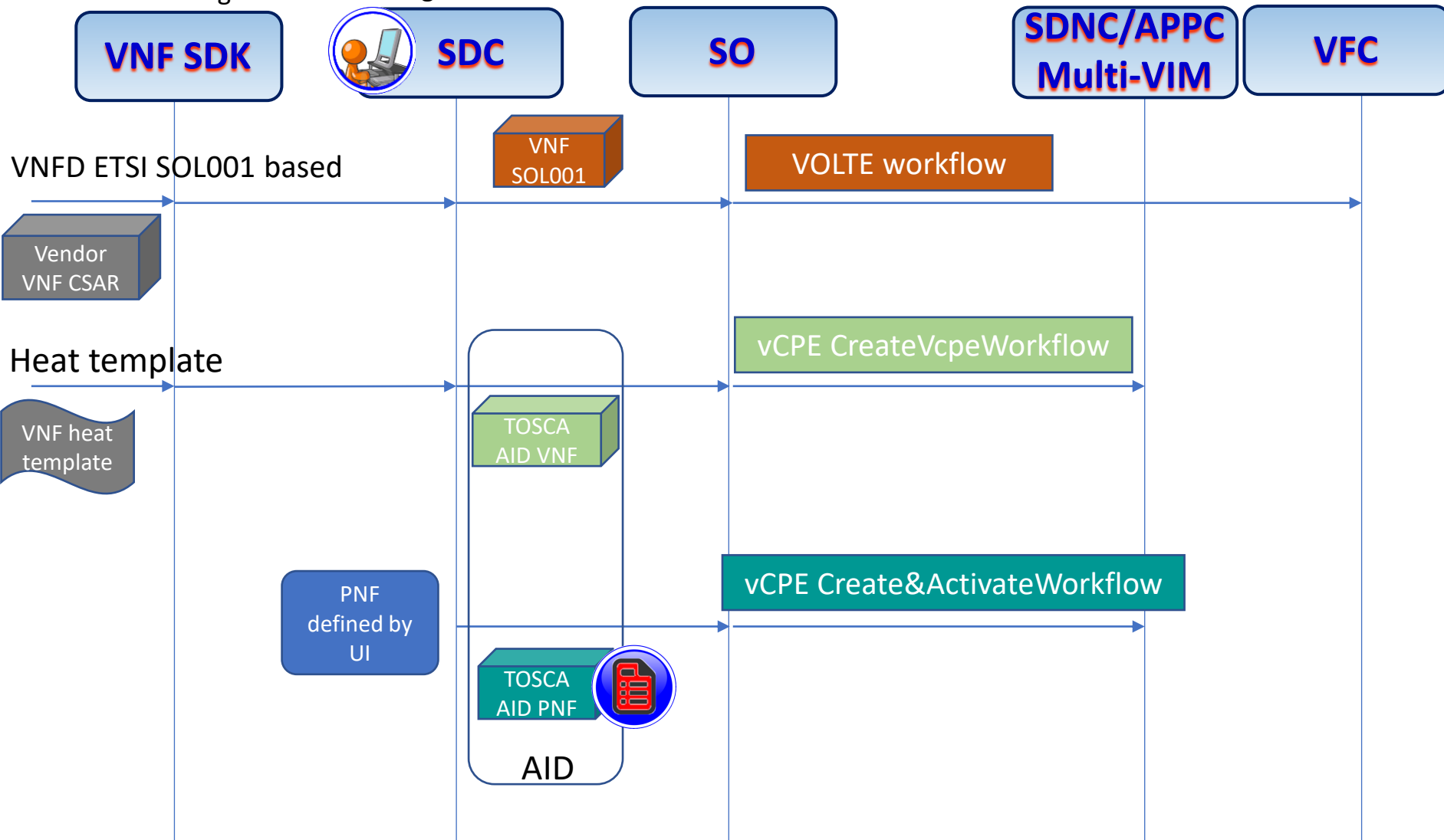

# xNF ONBOARDING Dependencies R4



Pre-onboarding



Onboarding Design Time

**VNF SDK**

**SDC**

**SO**

**SDNC/APPC Multi-VIM**

**VFC**

VNFD, **PNFD** ETSI SOL001



VNF SOL001

PNF SOL001

VOLTE workflow

Vendor VNF CSAR

Vendor PNF CSAR

Heat template

VNF heat template

vCPE CreateVcpeWorkflow



TOSCA AID VNF

PNF defined by UI

vCPE Create&ActivateWorkflow

TOSCA AID PNF



AID

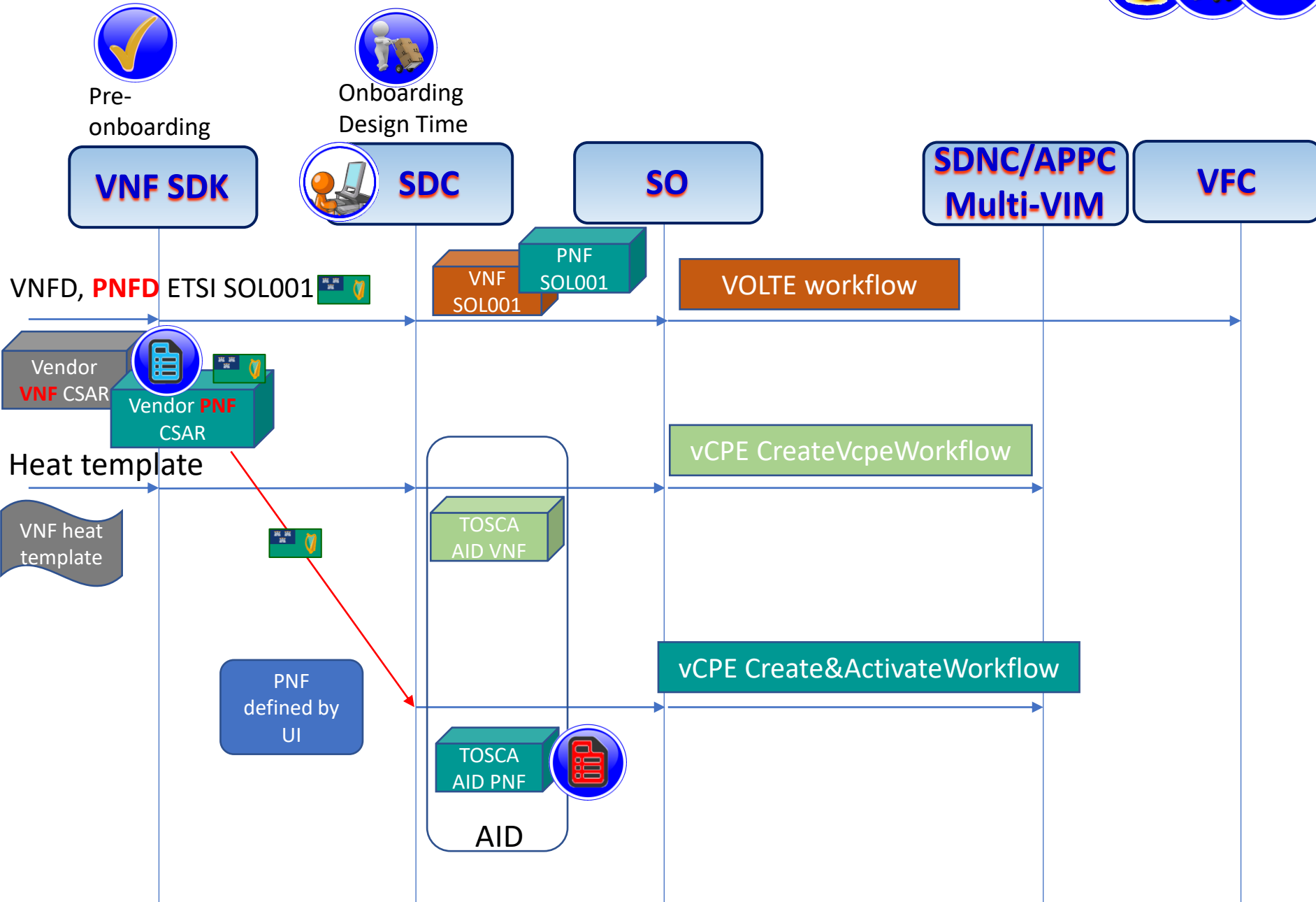

## DESIGN TIME & SDC



SDC CSAR Pkg



Design Time



Service Designer



# NFV Release 2: stage 2 and stage 3 specification summary

(\* ) Release 2 Stage 3 work items in "green"

Status as of Apr. 2018

- NFV-IEA 015**  
(NFV Information Model Report)
- + **NFV-IEA 016**  
(Papyrus Guidelines),
- NFV-IEA 017**  
(UML Modeling Guidelines),
- NFV-IEA 024**  
(NFV Information Model External Touchpoints)

**NFV-TST 008**  
(NFVI metrics)

**NFV-IEA 002**  
(Acceleration)

**NFV-IEA 003**  
(Acceleration)

**NFV-IEA 004**  
(Acceleration)

**NFV-IEA 010**  
(NFV-MANO Functional Reqs)

**NFV-IEA 013**  
**NFV-SOL005**

**SOL004**  
(VNF Packaging)  
**NFV-IEA 011**  
(VNF Pkg)

**NFV-SOL007**  
(NSD file structure)  
**NFV-IEA 014**  
(NS templates)

**NFV-SOL 001**  
**NFV-SOL 006**  
(VNF and NS Descriptors)

**NFV-IEA 007**  
**NFV-SOL 003**

**NFV-IEA 008**  
**NFV-SOL 002**

**NFV-IEA 006**

**NFV-IEA 005**

**Published!**

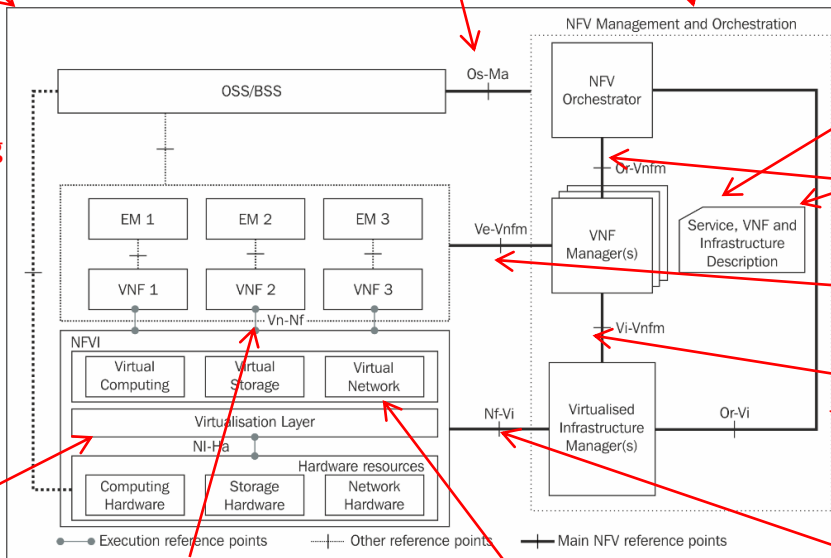

PNF Descriptor impacts

PNF package impacts

# PNF Descriptor (ETSI SOL 001)



## PNFD Service Template

Substituted by

**PNFD  
Abstract**

VirtualLinkable

DependsOn

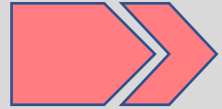

PNF

Properties:

NODE

Application (NF)  
Infrastructure (H/W)

PnfExtCp

NODE

VirtualLinkable

NsVirtualLink

VirtualLinkable

LEGEND:

Capabilities

Requirements

# DsnTm: PNFD > ONAP Platform Model



4 Design Time Activities: NF

Onboard Package > SDC catalog

## PNFD DESCRIPTOR

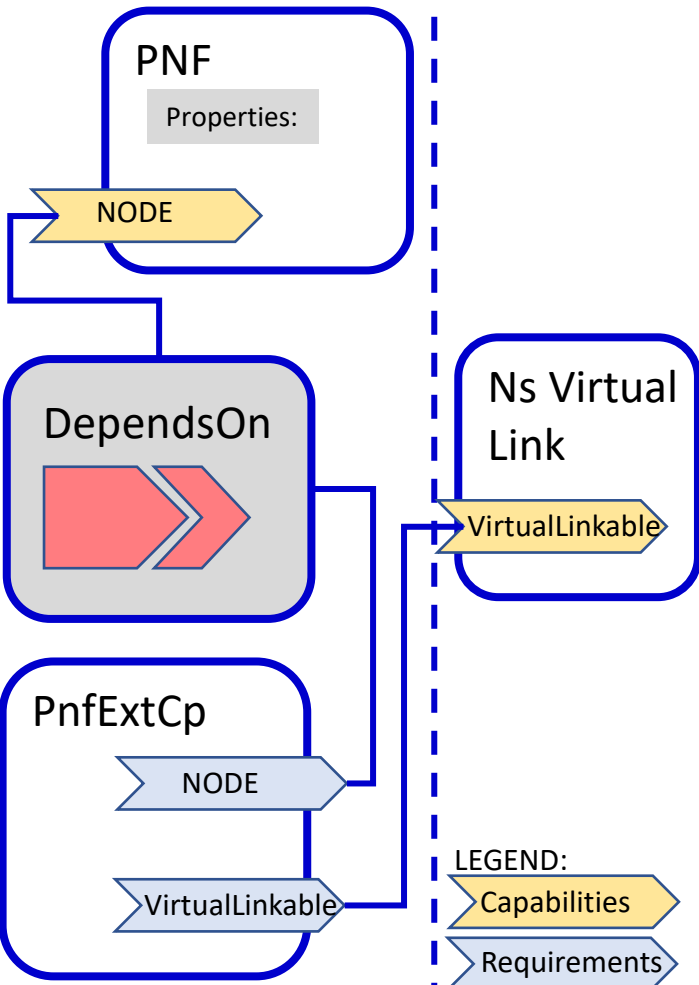

## PLATFORM MODEL (INTERNAL MODEL)

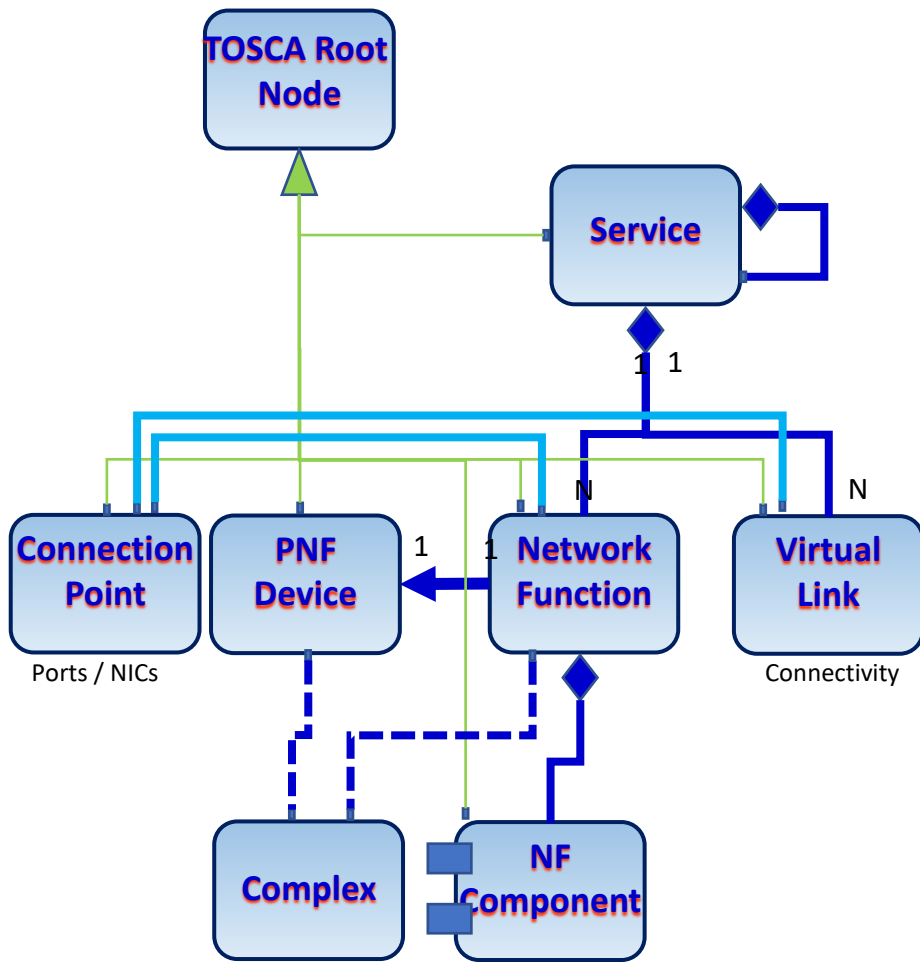

# DsnTm: PNFD > SDC AID



4 Design Time Activities: NF

Onboard Package > SDC catalog

## PNFD DESCRIPTOR

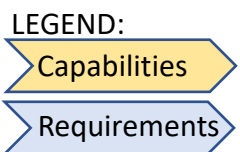
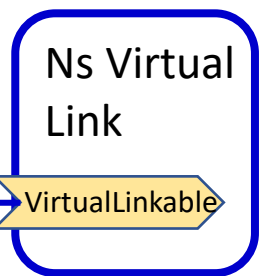
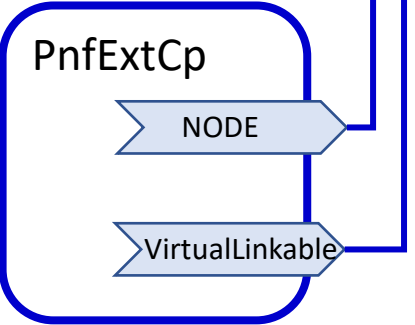
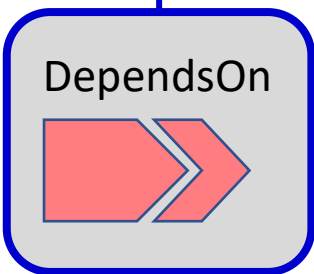
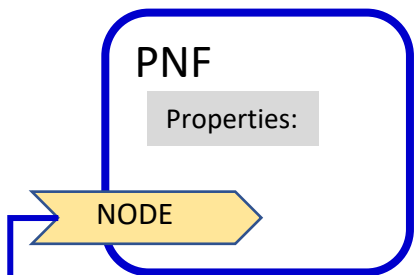

## SDC AID (Architecture Integration Document) Internal Model

# Design-Time Process



## DESIGN-TIME (SDC)

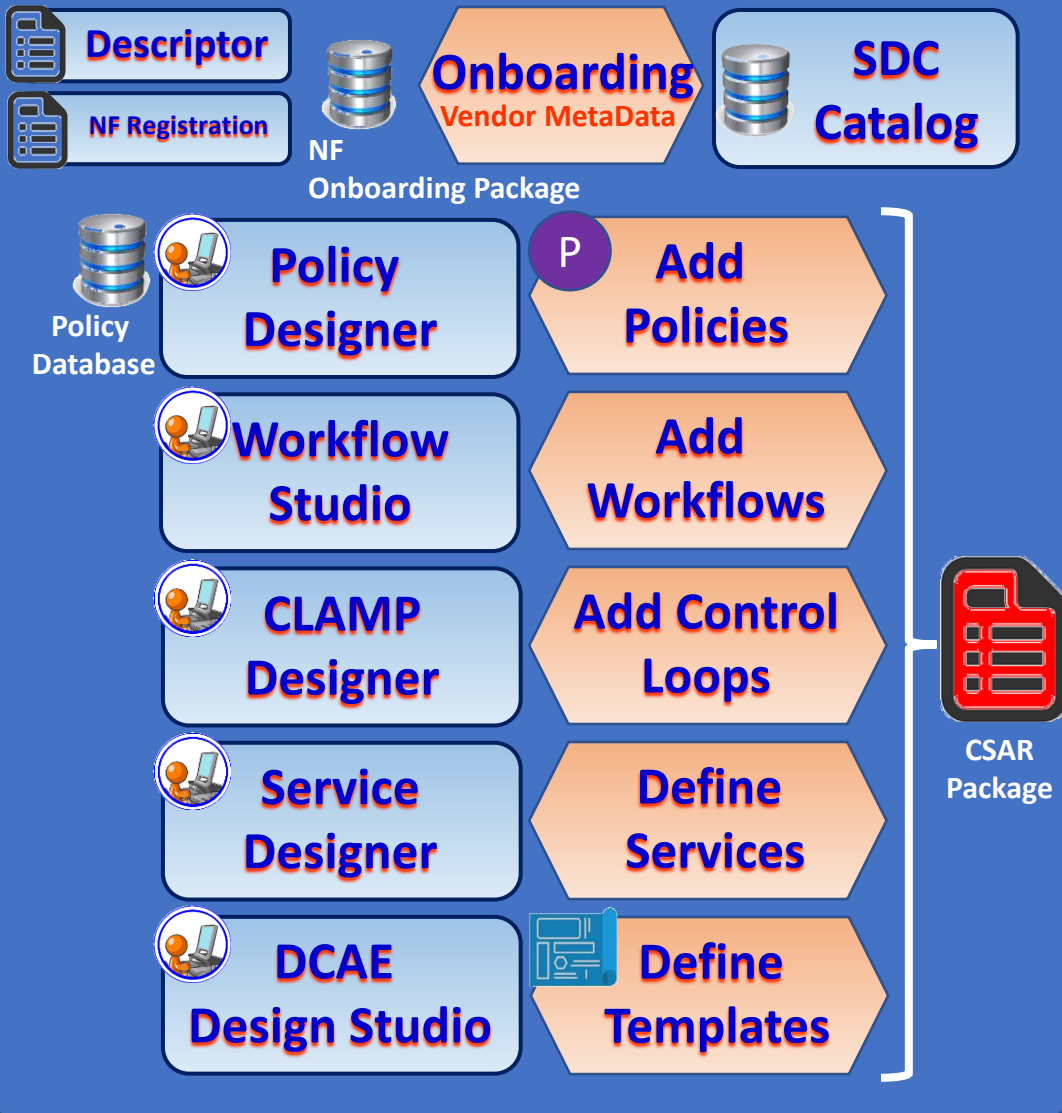

## ONAP RUN-TIME

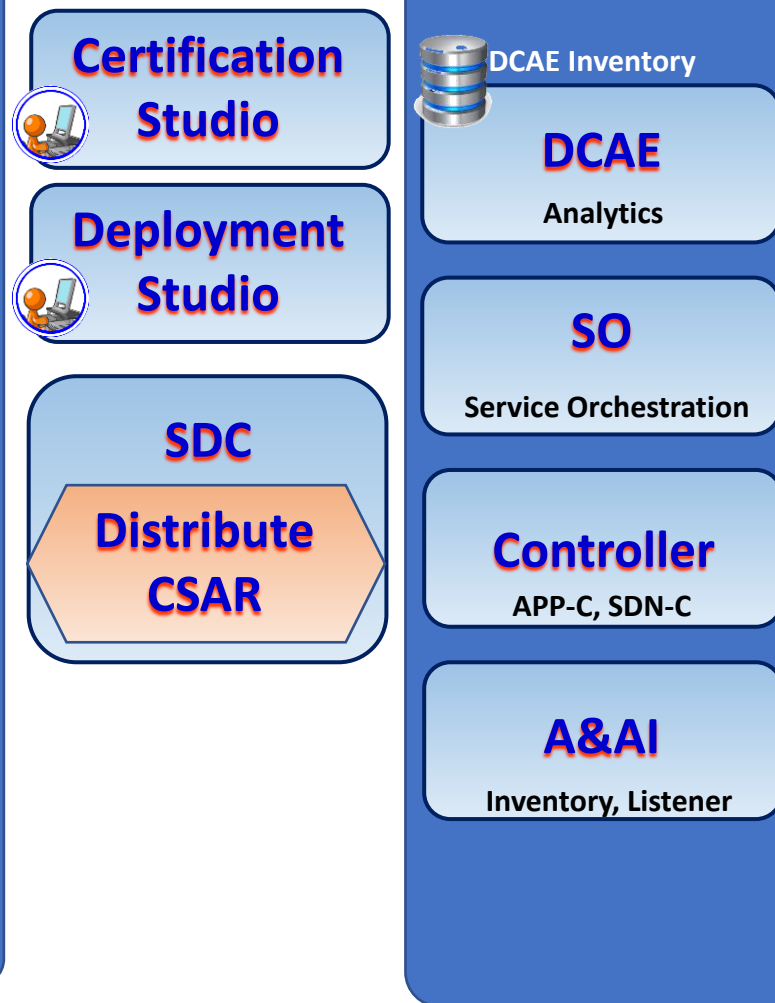



# Defining a Service



**4 Design Time Activities:**  
Designing a Service

Distribute



SDC Service CSAR  
Package

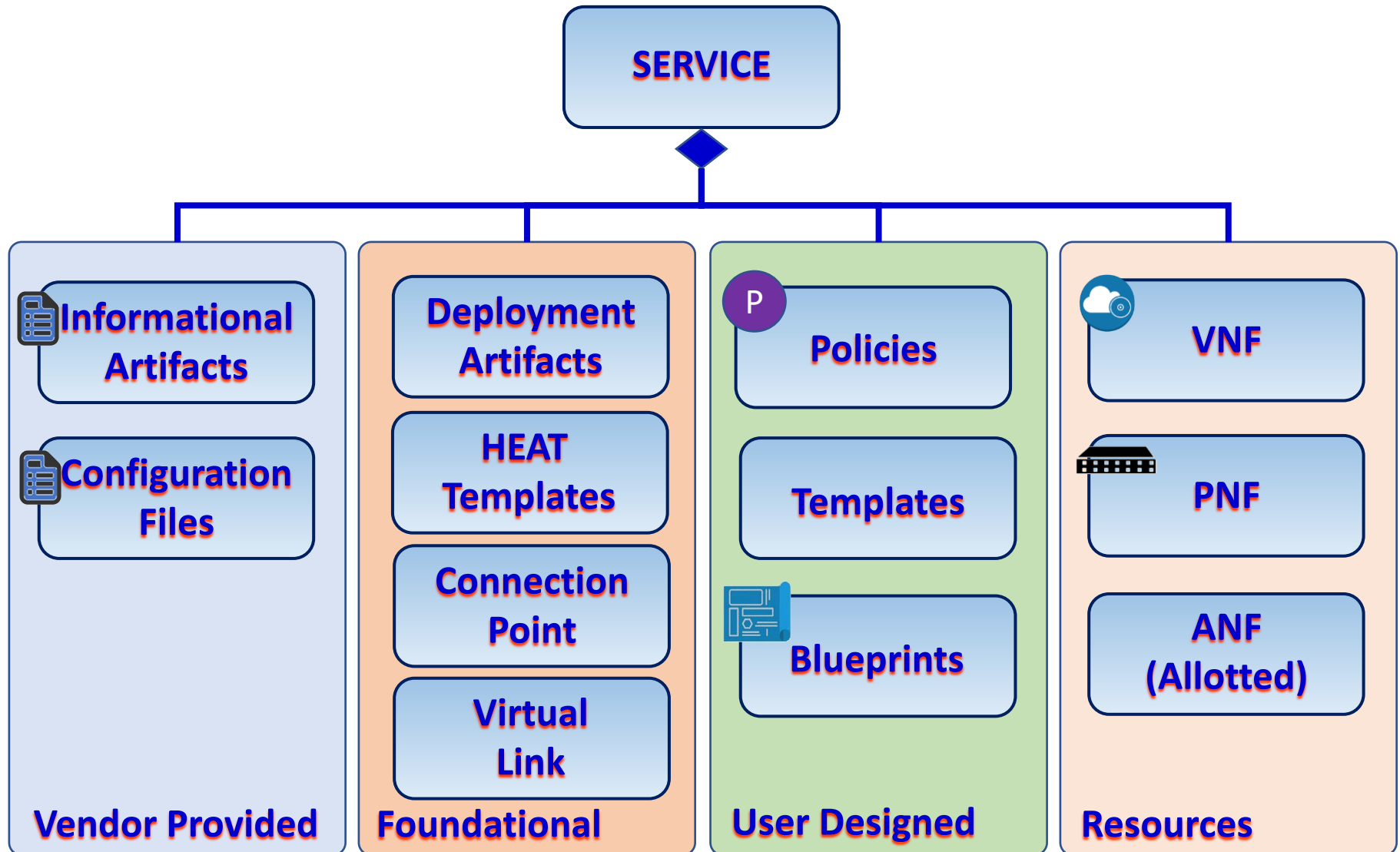

# R4: 5G Base Station (gNodeB)

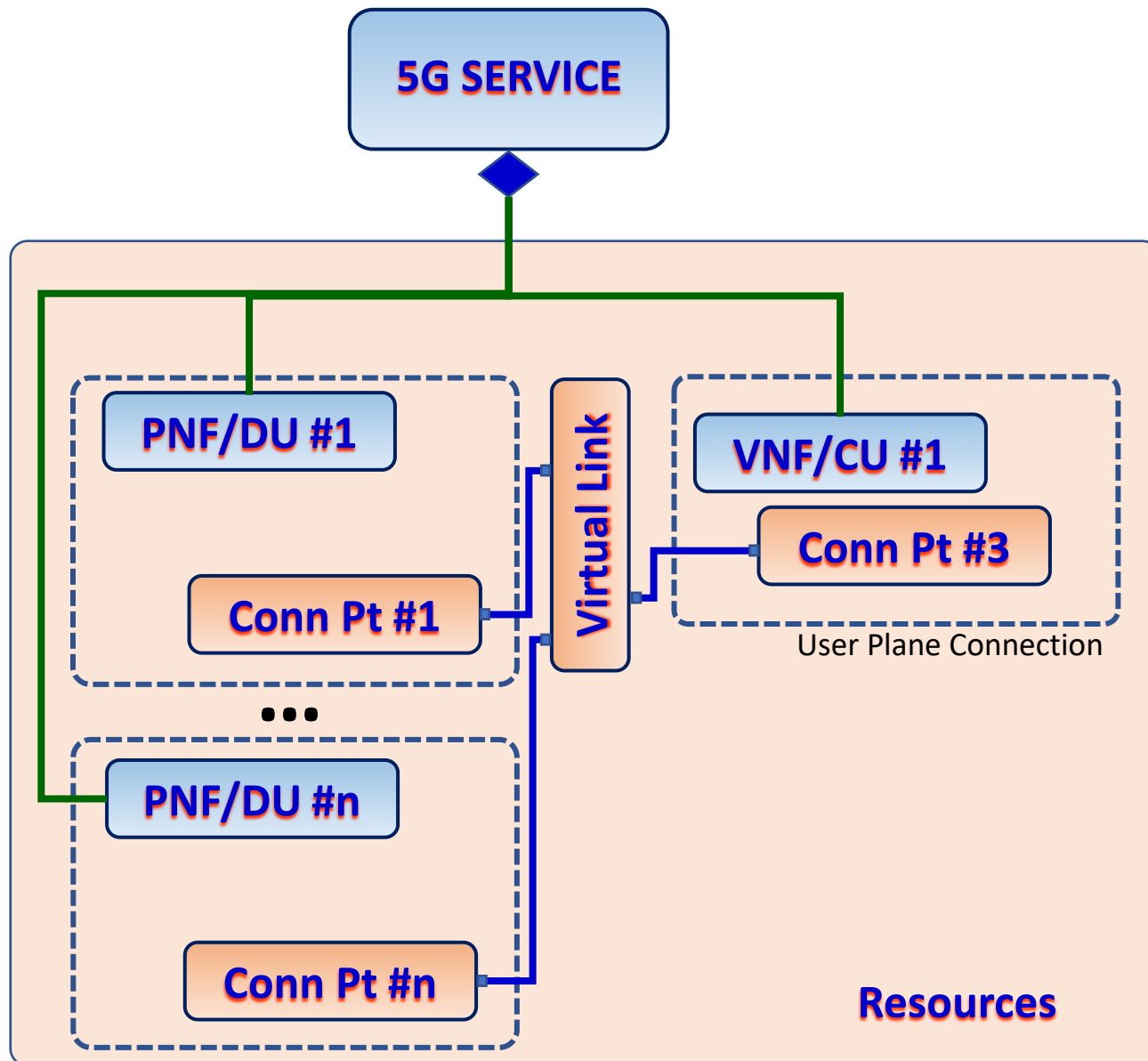
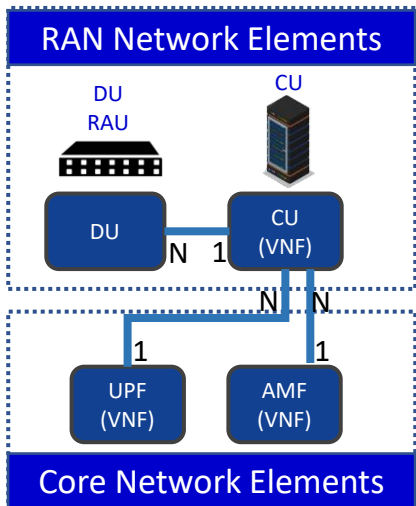

## VNF Requirements



NF Descriptor



Onboarding



Asset Manager



# VNF Requirement extension for PNF

- [VNFRQTS-506](#): [Supporting PNF package onboarding](#)
  - [VNFRQTS-507](#): Project scope to include **PNF**
  - [VNFRQTS-508](#): Add **PNFD** requirements
  - Section 5.1.6:
    - [VNFRQTS-499](#): **PNF** onboarding CSAR package structure based SOL004
    - [VNFRQTS-497](#): Adding package security requirements
  - Section 7.2:
    - Clarifications on the documentation requirements
    - [VNFRQTS-505](#): **PNF** onboarding package artifacts
    - [VNFRQTS-498](#): Add VES Event Registration requirement to **PNF** package
    - Clarifications on artifacts structure requirements
    - [VNFRQTS-496](#): supporting Ansible protocol in **PNF**

# ONAP VNF Descriptor (5.1.9) Requirements

R number	Description	Comments
<a href="#">R-35854</a>	The VNF Descriptor (VNFD) provided by VNF vendor <b>MUST</b> comply with TOSCA/YAML based Service template for VNF descriptor specified in ETSI NFV-SOL001.	Shall applicable to PNFD
<a href="#">R-65486</a>	The VNFD <b>MUST</b> comply with ETSI GS NFV-SOL001 document endorsing the above mentioned NFV Profile and maintaining the gaps with the requirements specified in ETSI GS NFV-IFA011 standard.	Shall applicable to PNFD
<a href="#">R-17852</a>	The VNFD <b>MAY</b> include TOSCA/YAML definitions that are not part of NFV Profile. If provided, these definitions <b>MUST</b> comply with TOSCA Simple Profile in YAML v.1.2.	Shall applicable to PND
<a href="#">R-46527</a>	A VNFD is a deployment template which describes a VNF in terms of deployment and operational behavior requirements. ... including topology, deployment aspect, and VNF lifecycle management (LCM) operations	PNF LCM is not defined yet
<a href="#">R-15837</a>	The major TOSCA Types specified in ETSI NFV-SOL001 standard draft	
<a href="#">R-54356</a> <a href="#">R-54876</a>	VNF Data Types	CpProtocolData AddressData L2AddressData L3AddressData LocationInformation CivicAddressElement
<a href="#">R-67895</a>	VNF Capability Types	VirtualLinkable
<a href="#">R-95321</a>	VNF Relationship Types	VirtualLinksTo
<a href="#">R-32155</a>	VNF Interface Types	
		PNF Node Types: PNF, PnfExtCp, Cp
		PBF Policy Types

# ONAP VNF CSAR Package (5.1.6) Requirements

R number	Description	Comments
<a href="#">R-51347</a>	The VNF package <b>MUST</b> be arranged as a CSAR archive as specified in TOSCA Simple Profile in YAML 1.2.	Shall applicable to PNF package
<a href="#">R-87234</a>	The VNF package provided by a VNF vendor <b>MAY</b> be either with TOSCA-Metadata directory (CSAR Option 1) or without TOSCA-Metadata directory (CSAR Option 2) as specified in ETSI GS NFV-SOL004. On-boarding entity (ONAP SDC) must support both options. <b>Note:</b> SDC supports only the CSAR Option 1 in Casablanca. The Option 2 will be considered in future ONAP releases,	Shall applicable to PNF package
<a href="#">R-10087</a>	The VNF package <b>MUST</b> contain all standard artifacts as specified in ETSI GS NFV-SOL004 including Manifest file, VNFD (or Main TOSCA/YAML based Service Template) and other optional artifacts. CSAR Manifest file as per SOL004 - for example ROOT\ <b>MainServiceTemplate.mf</b>	Shall applicable to PNF package
<a href="#">R-01123</a>	The VNF package Manifest file <b>MUST</b> contain: VNF package meta-data, a list of all artifacts (both internal and external) entry's including their respected URI's, an algorithm to calculate a digest and a digest result calculated on the content of each artifacts, as specified in ETSI GS NFV-SOL004. The VNF Package <b>MUST</b> include VNF Identification Data to uniquely identify the resource for a given VNF provider. The identification data must include: an identifier for the VNF, the name of the VNF as was given by the VNF provider, VNF description, VNF provider, and version.	Shall applicable to PNF package With new valid names/values <ul style="list-style-type: none"> <li>- pnf_provider_id</li> <li>- pnf_product_name</li> <li>- pnf_release_date_time</li> <li>- pnf_package_version</li> </ul>
<a href="#">R-21322</a>	The VNF provider <b>MUST</b> provide their testing scripts to support testing as specified in ETSI NFV-SOL004 - Testing directory in CSAR	Should applicable to PNF package
<a href="#">R-26885</a>	The VNF provider <b>MUST</b> provide the binaries and images needed to instantiate the VNF (VNF and VNFC images) either as: <ul style="list-style-type: none"> <li>• Local artifact in CSAR: ROOT\Artifacts\<b>VNF_Image.bin</b></li> <li>• externally referred (by URI) artifact in Manifest file (also may be referred by VNF Descriptor)</li> </ul> Note: Currently, ONAP doesn't have the capability of Image management, we upload the image into VIM/VNFM manually.	May applicable to PNF package Not supported with current release
<a href="#">R-40820</a>	The VNF provider <b>MUST</b> enumerate all of the open source licenses their VNF(s) incorporate. CSAR License directory as per ETSI SOL004. for example ROOT\Licenses\ <b>License_term.txt</b>	May applicable to PNF package
R-xxxxx	<b>VNF Package Authenticity</b>	May applicable to PNF package

# PNF on-boarding requirements (7.2)

R number	Description	Comments
<a href="#">R-77707</a>	The <b>xNF provider MUST</b> include a Manifest File that contains a list of <b>all</b> the components in the <b>xNF package</b>	<a href="#">OK</a> . Overlapped with <a href="#">R-10087</a> in section 5.1.6.3
<a href="#">R-66070</a>	The xNF Package <b>MUST</b> include xNF Identification Data to uniquely identify the resource for a given xNF provider. The identification data must include: an identifier for the xNF, the name of the xNF as was given by the xNF provider, xNF description, xNF provider, and version.	Part of the descriptor
<a href="#">R-98617</a>	The xNF provider <b>MUST</b> provide information regarding any dependency (e.g., affinity, anti-affinity) with other xNFs and resources.	Part of the descriptor
<a href="#">R-22346</a>	The VNF package <b>MUST</b> provide VES Event Registration for all VES events provided by that xNF.	VES event Registration Should be applicable to PNF
<a href="#">R-89571</a>	The xNF <b>MUST</b> support and provide artifacts for configuration management using at least one of the following technologies; a) Netconf/YANG, b) Chef, or c) Ansible.	
<a href="#">R-30278</a>	The xNF provider <b>MUST</b> provide a Resource/Device YANG model as a foundation for creating the YANG model for configuration. This will include xNF attributes/parameters and valid values/attributes configurable by policy.	
<a href="#">R-27711</a>	The xNF provider <b>MUST</b> provide an XML file that contains a list of xNF error codes, descriptions of the error, and possible causes/corrective action	Not the proposed FM dictionary
<a href="#">R-74763</a>	The xNF provider <b>MUST</b> provide an artifact per xNF that contains all of the xNF Event Records supported. The artifact should include reference to the specific release of the xNF Event Stream Common Event Data Model document it is based on. (e.g., <a href="#">VES Event Listener</a> )	VES event Listener
<a href="#">R-35851</a>	The xNF Package <b>MUST</b> include xNF topology that describes basic network and application connectivity internal and external to the xNF including Link type, KPIs, Bandwidth, latency, jitter, QoS (if applicable) for each interface.	Part of the descriptor?
<a href="#">R-26881</a>	The xNF provider <b>MUST</b> provide the binaries and images needed to instantiate the xNF (xNF and VNFC images).	Not supported by Casablanca
<a href="#">R-96634</a>	The xNF provider <b>MUST</b> describe scaling capabilities to manage scaling characteristics of the xNF.	Not supported by PNF
<a href="#">R-04298</a>	The xNF provider <b>MUST</b> provide their testing scripts to support testing.	Testing Requirements.
<a href="#">R-58775</a>	The xNF provider <b>MUST</b> provide software components that can be packaged with/near the xNF, if needed, to simulate any functions or systems that connect to the xNF system under test. This component is necessary only if the existing testing environment does not have the necessary simulators.	
<a href="#">R-85653</a>	The xNF <b>MUST</b> provide metrics (e.g., number of sessions, number of subscribers, number of seats, etc.) to ONAP for tracking every license.	Only if Licensing is needed
<a href="#">R-40827</a>	The xNF provider <b>MUST</b> enumerate all of the open source licenses their xNF(s) incorporate.	
<a href="#">R-85991</a>	The xNF provider <b>MUST</b> provide a universal license key per xNF to be used as needed by services (i.e., not tied to a VM instance) as the recommended solution. The xNF provider may provide pools of Unique xNF License Keys, where there is a unique key for each xNF instance as an alternate solution. Licensing issues should be resolved without interrupting in-service xNFs.	
<a href="#">R-47849</a>	The xNF provider <b>MUST</b> support the metadata about licenses (and their applicable entitlements) as defined in this document for xNF software, and any license keys required to authorize use of the xNF software. This metadata will be used to facilitate onboarding the xNF into the ONAP environment and automating processes for putting the licenses into use and managing the full lifecycle of the licenses.	



# Q&A







# REFERENCES / APPENDIX / BACKUP SLIDES

Benjamin Cheung, PhD

## VNF SDK Updates



Benjamin Cheung, PhD

NF Descriptor	
Onboarding	
Asset Manager	

# SDK ENHANCEMENTS



sdsc.api.fe.simplifiedemo.onap.org:30206/sdc1/portal#/dash-board

SDC v.1.3.3-SNAPSHOT

HOME CATALOG ONBOARD DCAE-DS WORKFLOW

ACTIVE PROJECTS 4

- Check Out 4
- Check In 0

FOLLOWED PROJECTS 16

- Ready For Testing 0
- In Testing 0
- Certified 16

ADD

Import VFC

Import VSP

Import DCAE asset

Import VF

Select one of the software product component below:

Name	Vendor	Category
1541f87b-cf09-4597-8076	cd18cbda-7af7-41d5-9df4	Generic Abstract
<b>VSP Description:</b> vendor software product		
<b>VSP's Meta Data:</b> Name: 1541f87b-cf09-4597-8076 Lifecycle: CERTIFIED Creator: Carlos Santana		
UUID: c988a8d5-aaf5-48ff-a33f-0aaa307e016 Version: 1.0 Modifier: Carlos Santana		
6077b558-4f67-4dc7-8cce	c94dfaad-d116-41d8-8178	Generic Abstract
774350dc-b0df-48c0-bc12	a9236f3b-9b13-45b2-a172	Generic Abstract
7ad18697-c393-4841-8599	fcc57795-7368-4600-98d5	Generic Abstract
934d85cd-01ff-493c-bcbe	07599e05-7cea-4a40-b978	Generic Abstract
ac743abf-b235-44ef-8493	4cedaece-7762-4395-adcc	Generic Abstract
afb1efb7-90b9-419f-9aa3	ed8e0862-e6a8-4bef-b2aa	Generic Abstract
e18314f7-91ff-4e56-a55d	b7265786-80f5-4c39-adf5	Generic Abstract

Opening 1743e162775491394bcc77f62ec64d6.csar

You have chosen to open:

- 1743e162775491394bcc77f62ec64d6.csar  
which is: csar File (43.7 KB)  
from: bleib

What should Firefox do with this file?

- Open with
- Save File
- Do this automatically for files like this from now on.

OK Cancel

# SDK ENHANCEMENTS



Demo1

V0.1

IN DESIGN CHECK OUT

Certify

Check

General

Information Artifact

TOSCA Artifacts

Composition

Activity Log

Properties Assignment

## TOSCA Artifacts

Name	Type	Version
› Tosca Model	TOSCA_CSAR	0
› Tosca Template	TOSCA_TEMPLATE	0

# VNF SDK Impacts

- [VNFSDK-337](#): Supporting PNF package onboarding
  - [VNFSDK-338](#): Project scope to include PNF
  - [VNFSDK-339](#): PNF CSAR structure based SOL004
  - [VNFSDK-340](#): PNF manifest file
  - [VNFSDK-341](#): PNFD validation based on SOL001
  - [VNFSDK-342](#): Support packaging security
  - [VNFSDK-343](#): Enhancement of the test on PNF package

## PLATFORM MODEL / MODELING A SERVICE



Benjamin Cheung, PhD

Platform Model	
Design Time	
Service Designer	

# Platform Data Model

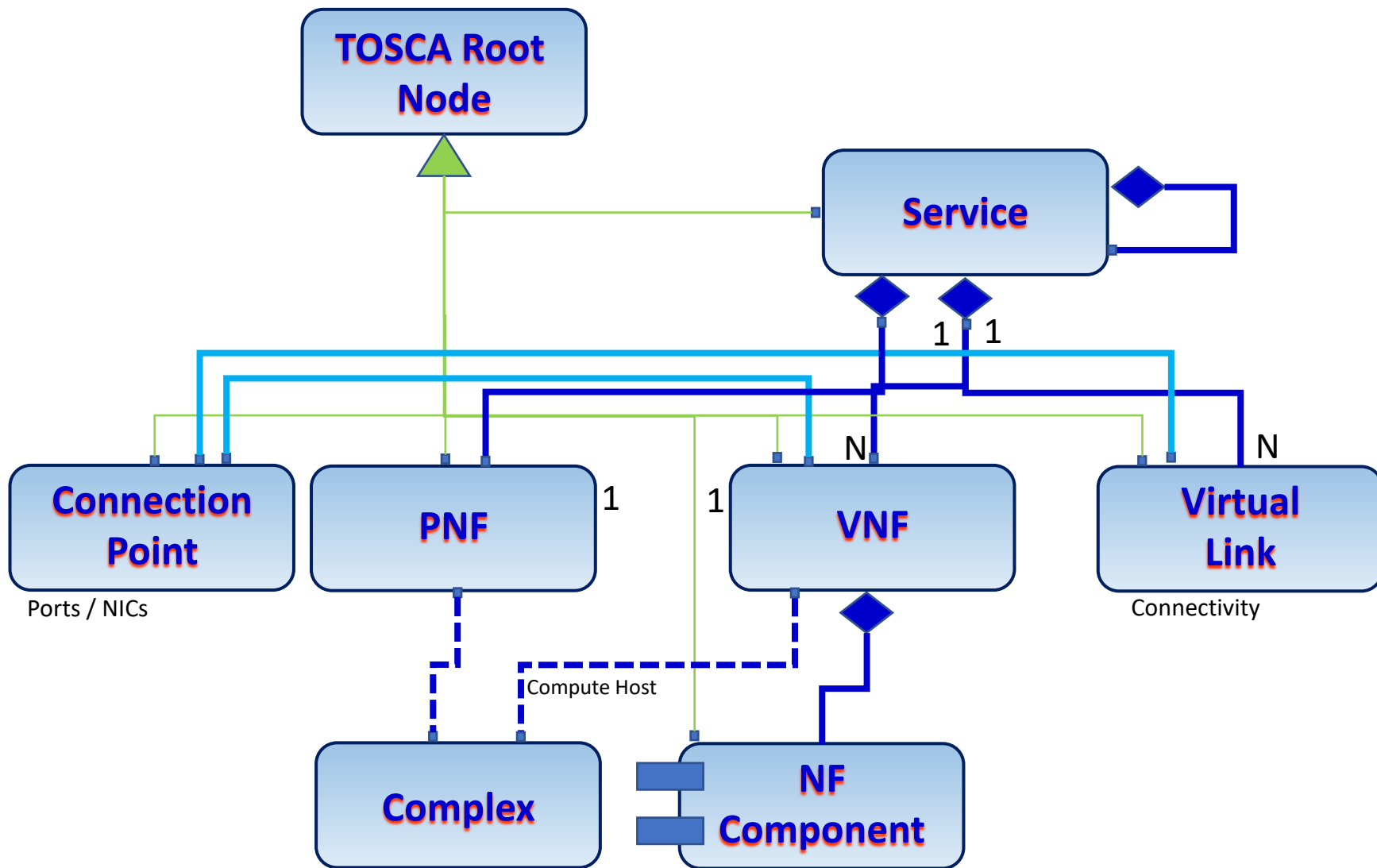

Design time view of a service  
Internal representation of a model  
Onboarding Model > SDC produces

# Platform (Internal) Information Model

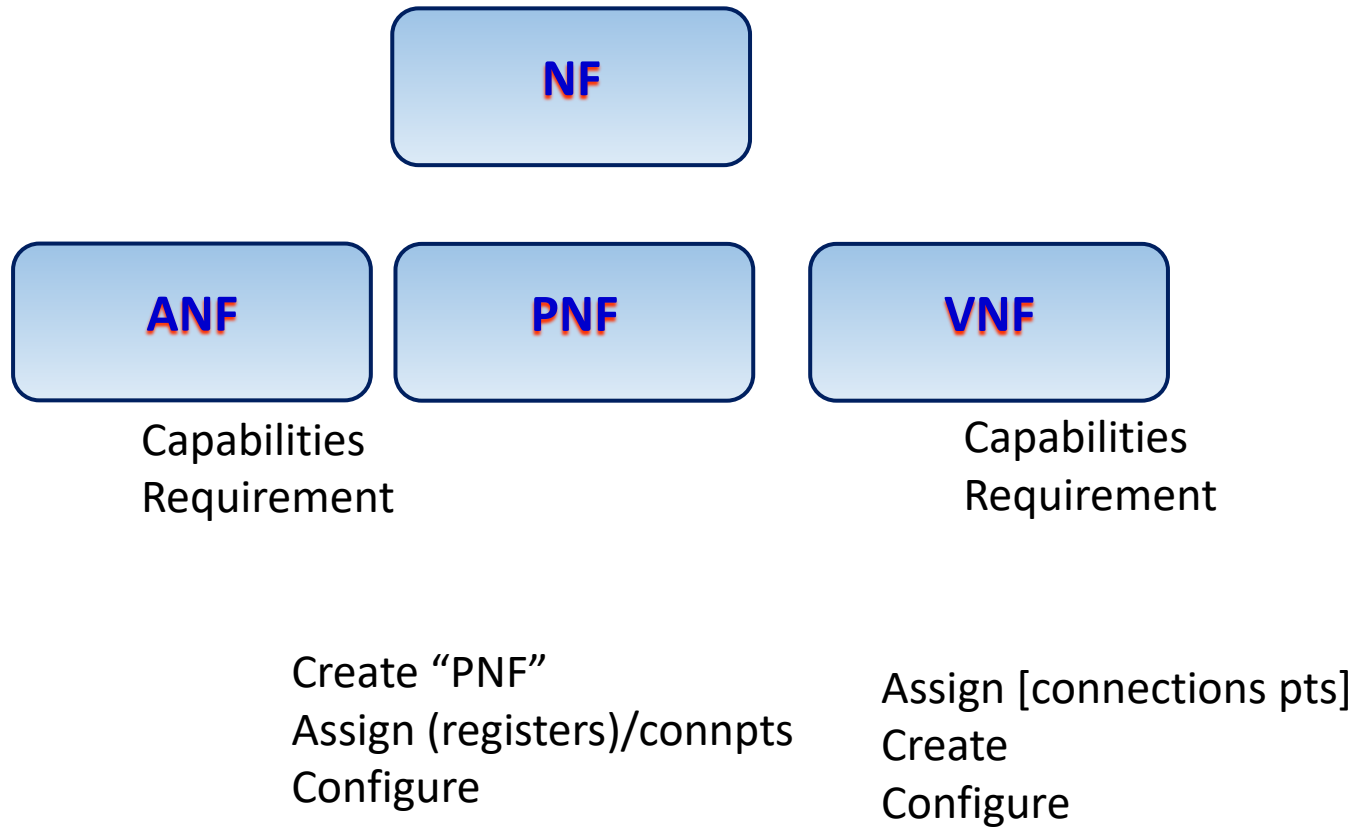



# PNF Descriptor > ONAP Platform Model



## PNFD DESCRIPTOR

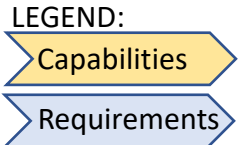
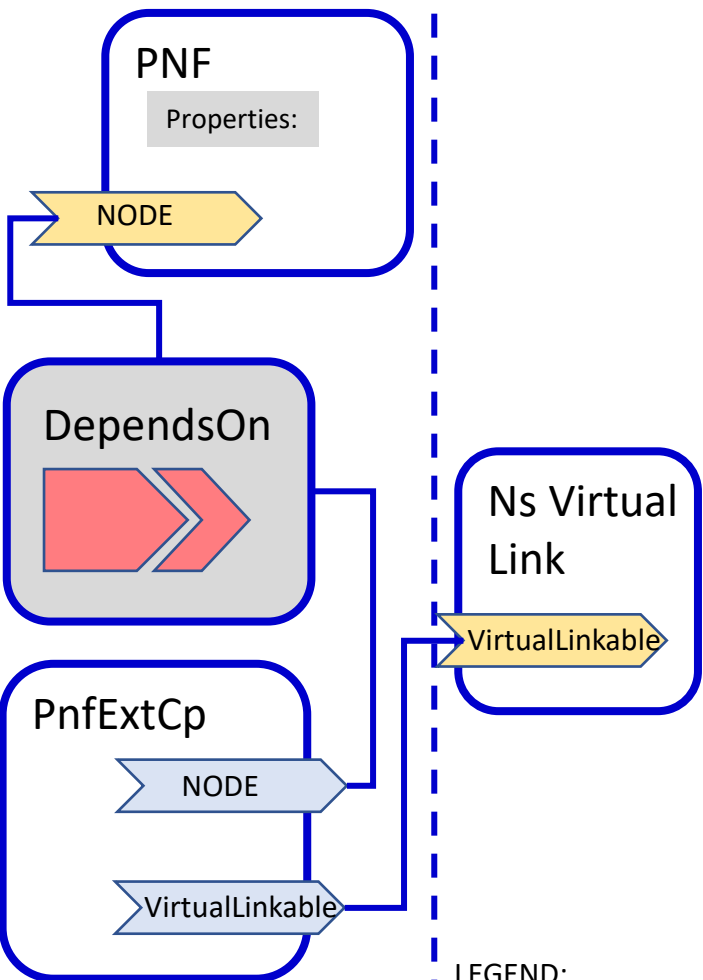

## PLATFORM MODEL (INTERNAL MODEL)

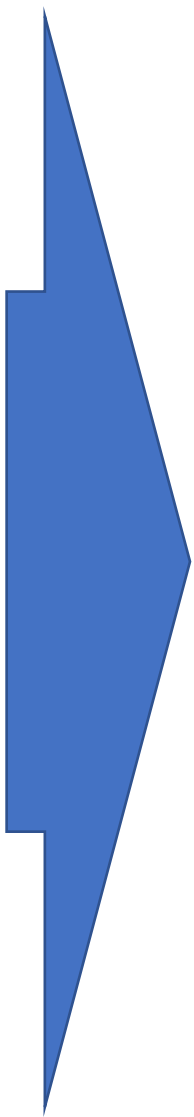
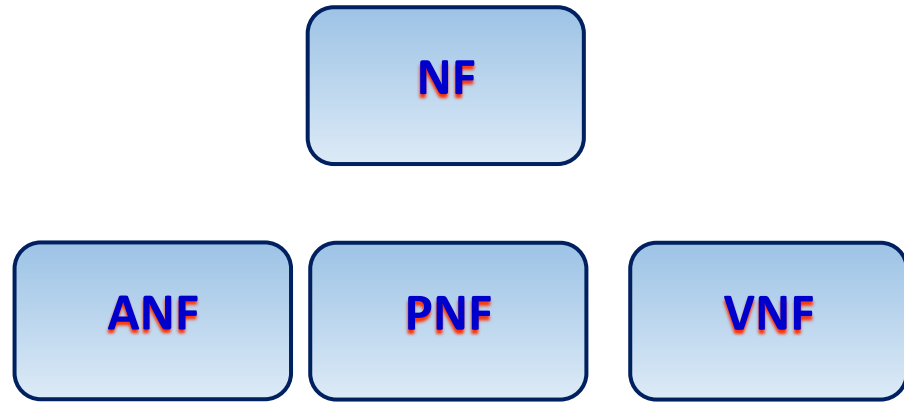

# Policy Example



## DESIGN-TIME (SDC)

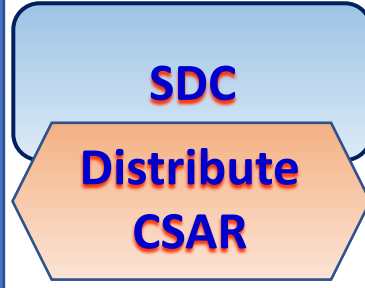
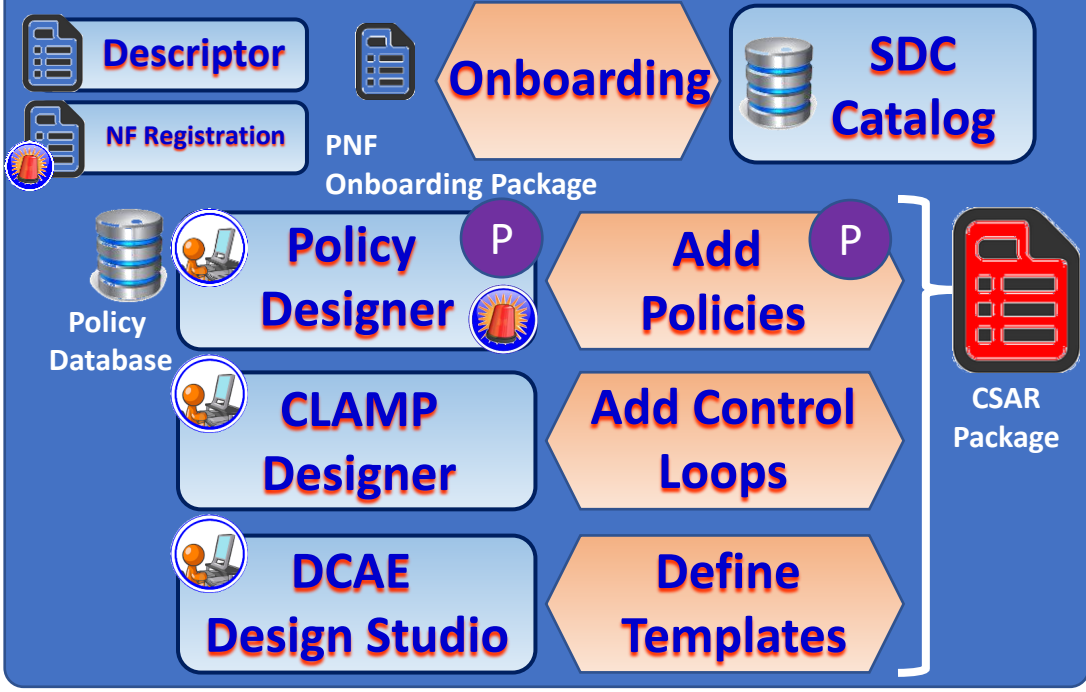

## DCAE (Run Time)

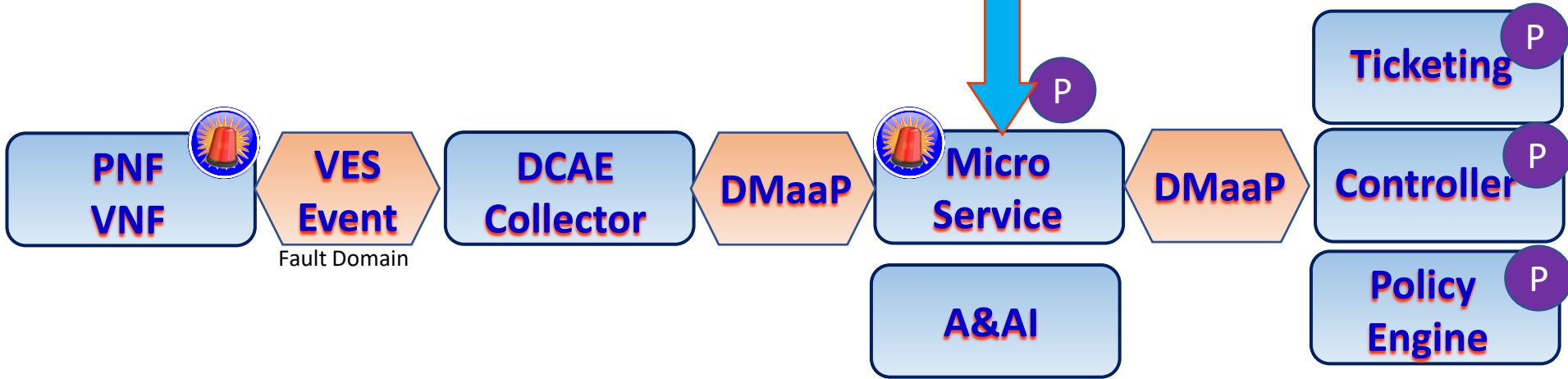
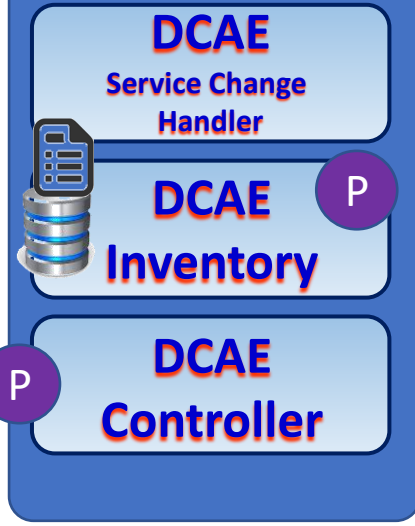

# Onboarding and Design Time

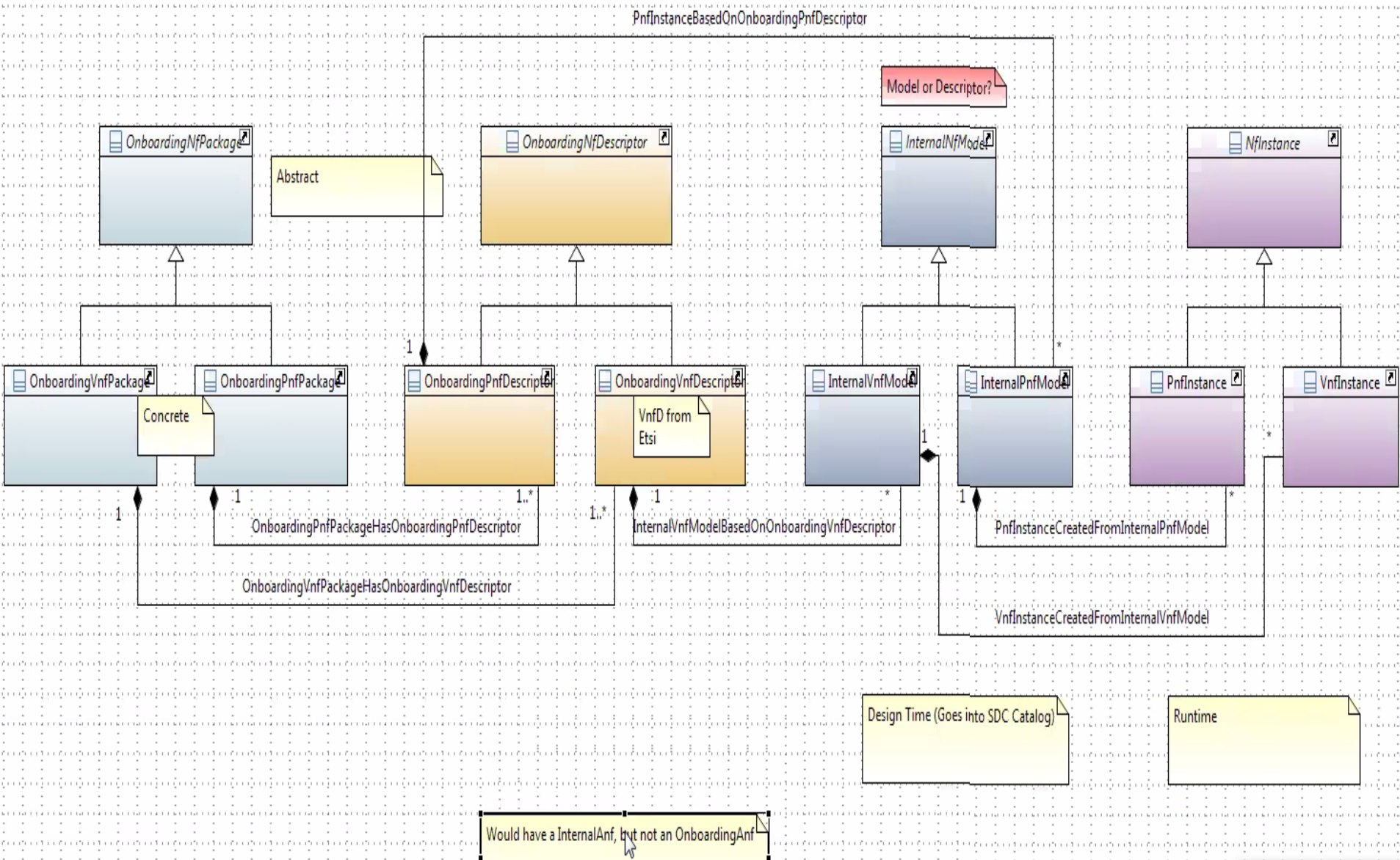



# 5G RAN Wireless Systems



Benjamin Cheung, PhD

# 3GPP Release 15, IMT-2020 = 5G



## eMBB (enhanced Mobile Broadband)

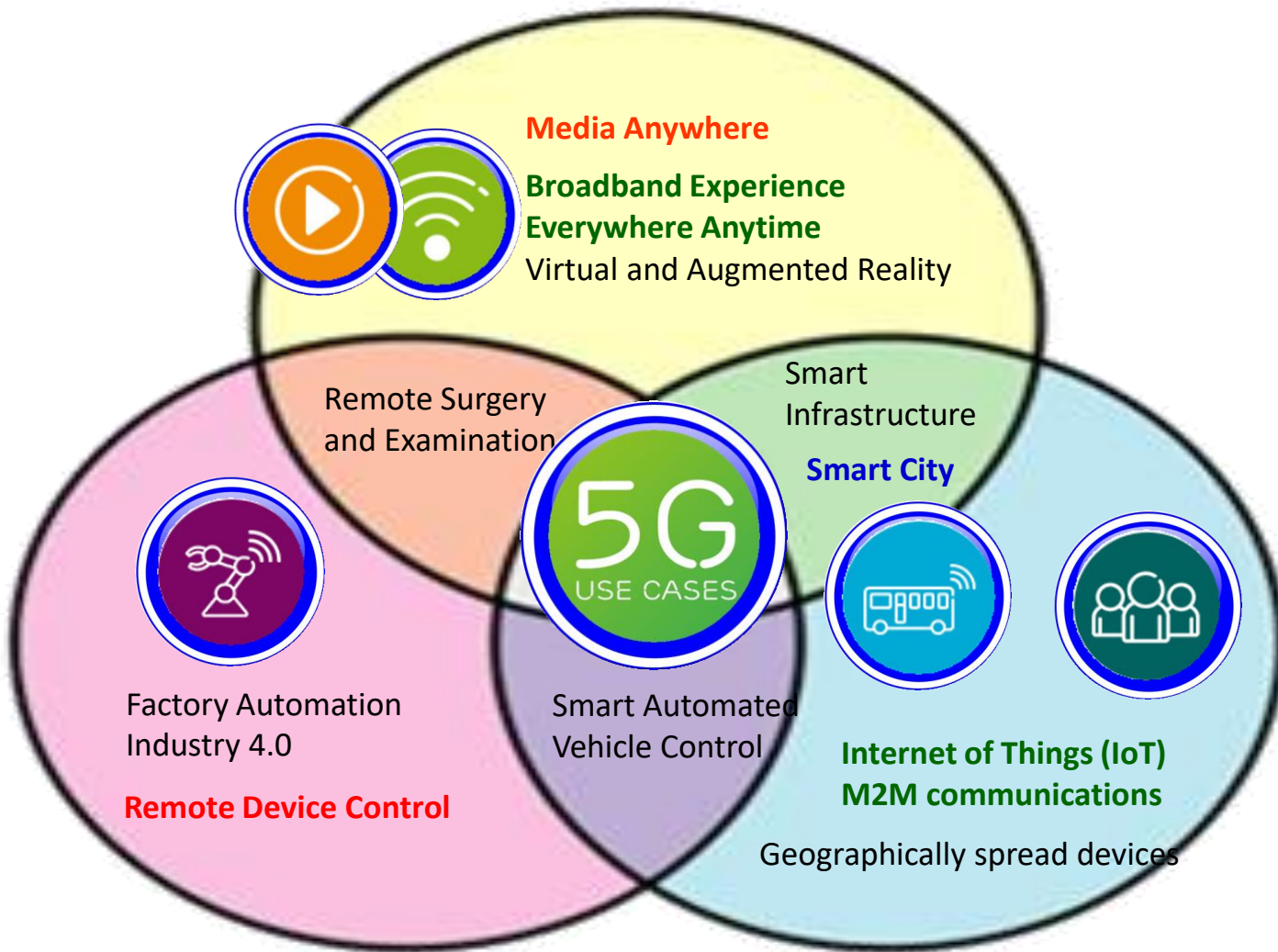

- Smart
- Connected
- Collaborate
- Access
- Interactive
- Aware

**URLLC (Ultra Reliable Low Latency Communications)**

**mMTC (massive Machine Type Communications)**

# 5G Key Technology Components



**New Spectrum (Rel 15, 52.6 GHz/39 GHz, Rel 16 > 52.6 GHz)**



**Advanced Beamforming**



**Multi-Connectivity (NSA, SA, Option 3, 4, 7)**



**Network Slicing**



**Edge Computing**



**Software Defined Networking (SDN)**



**Network Functions Virtualization (NFV)**



**Fog Computing (FC)  
Mobile Edge Computing (MEC)**



# 5G RAN Wireless Systems & ONAP



# 5G RAN Wireless Network

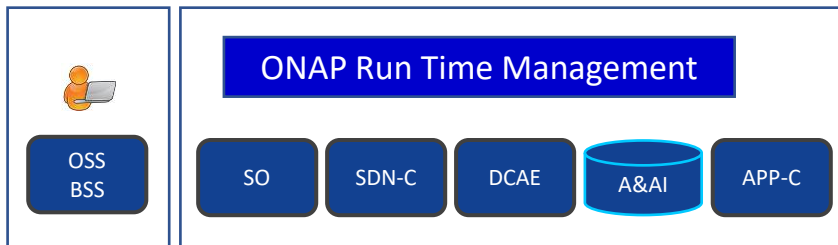

SO – Service Orchestrator  
 SDN-C – Service Design Network Controller  
 DCA&E – Data Collection Analytics & Events  
 A&AI – Available & Active Inventory  
 APP-C – Application Control

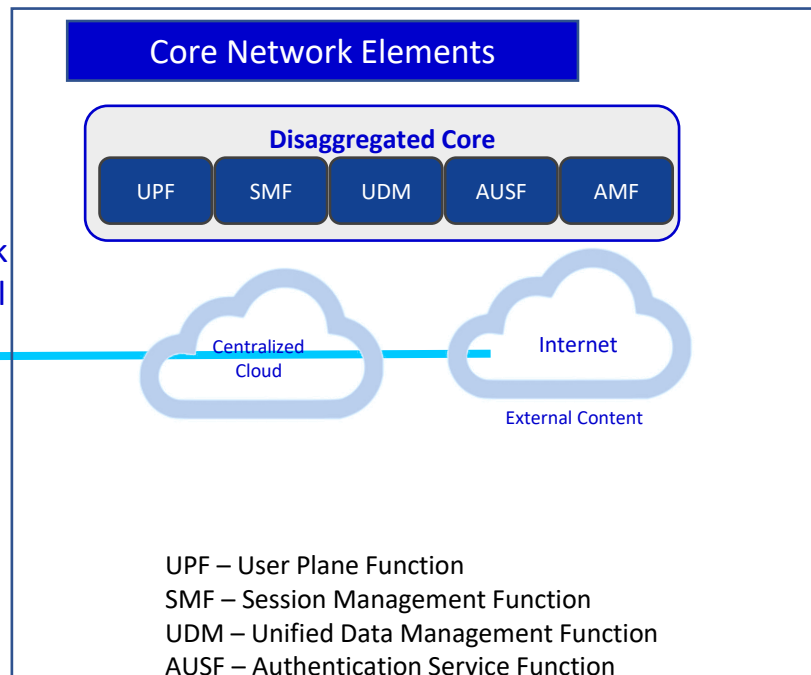
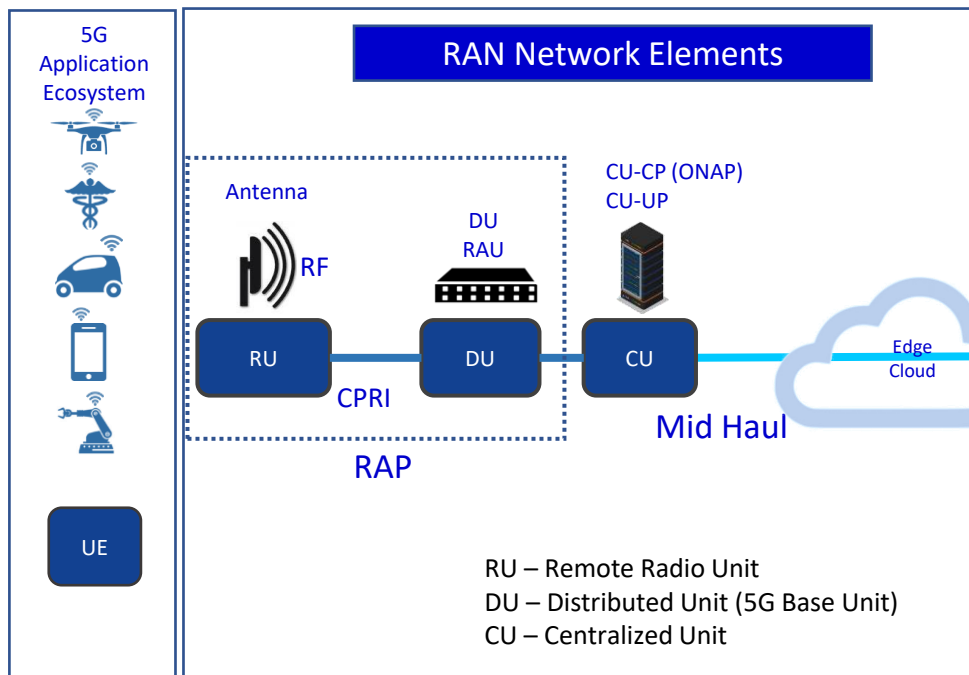



# R4: Modeling a 5G Service

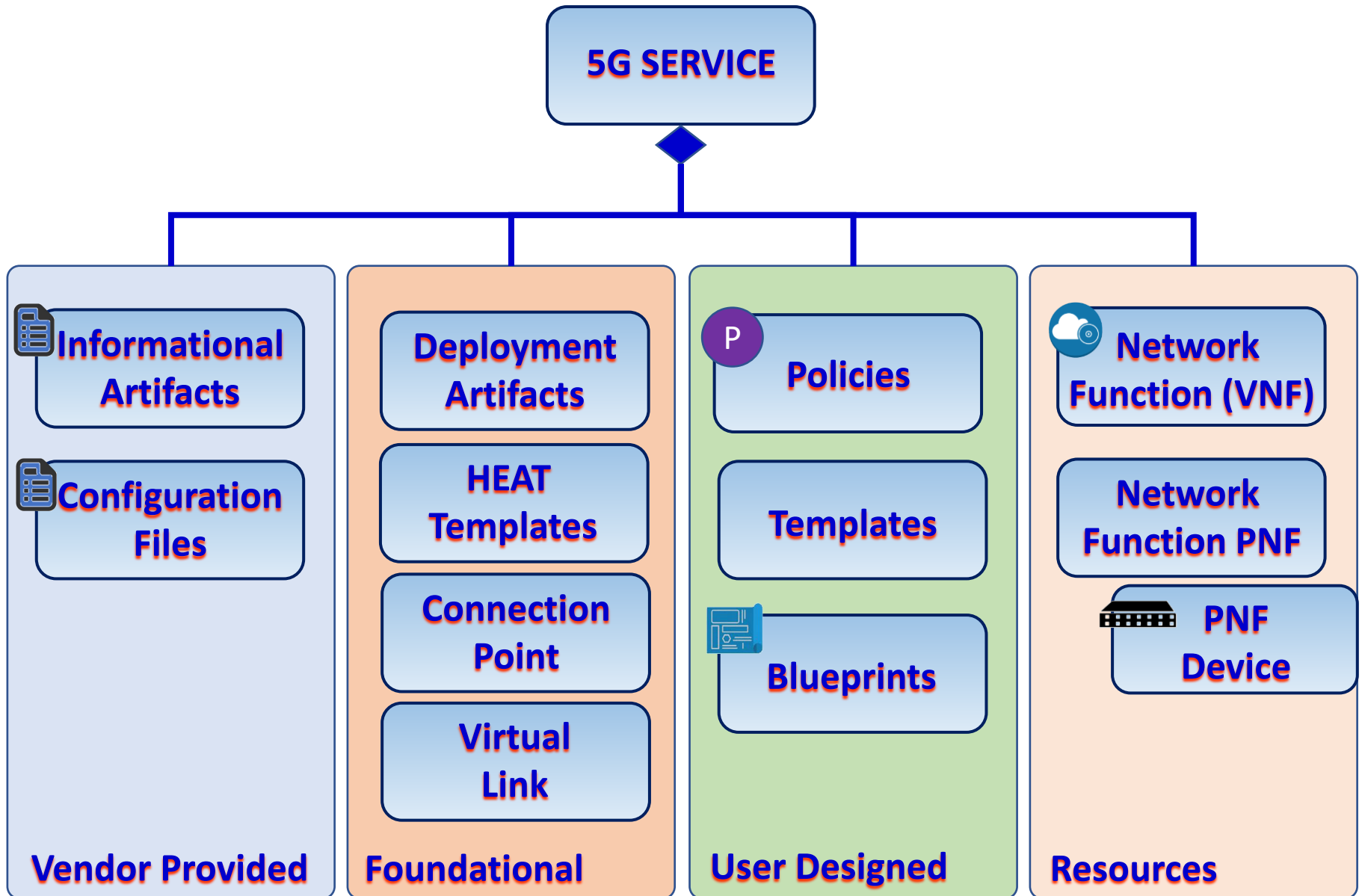

# R4: 5G Base Station (gNodeB)



## RAN Network Elements

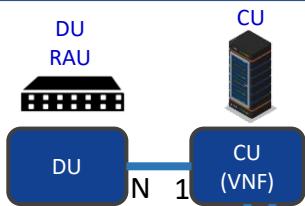

## Core Network Elements

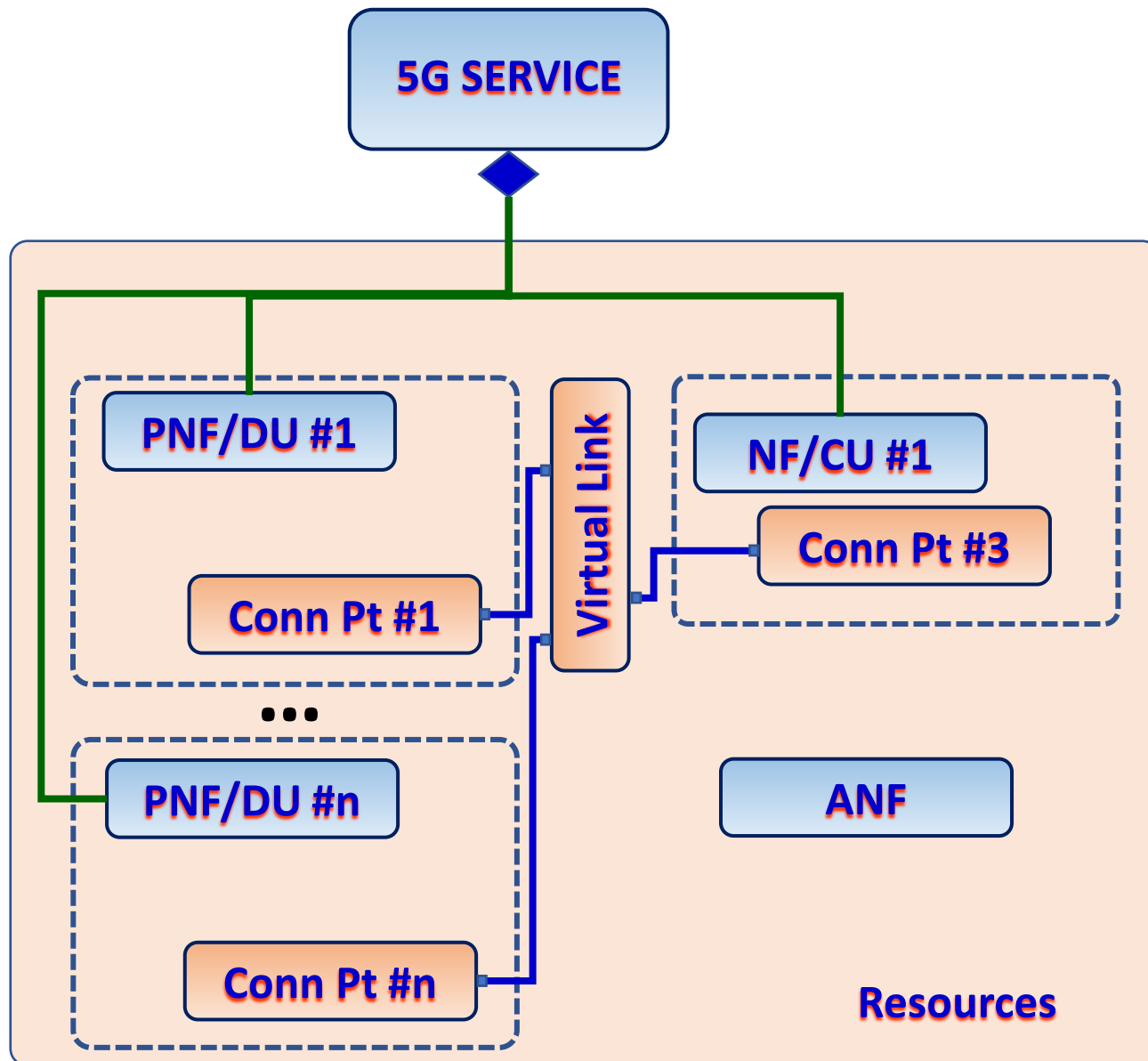
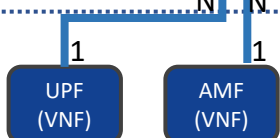

## Configurations



# MODELING WITHIN A PNF (DU)

## 5G DU (PNF)

NF PNF – “Application” S/W does 5G voice/data  
N/F Node Type  
Hardware PNF - Modem (5G DU) [Hardware]  
H/W Node Type

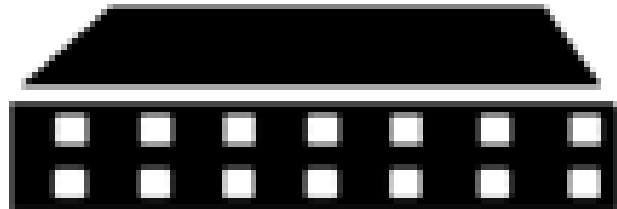

Sub-Component #1



Sub-Component #2

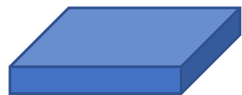

Sub-Component #n



SFP #1 = Port #1



SFP #n = Port #n



Software Function of a DU

**Network Function**

“Hardware Aspects of a PNF”

**Connection Point**

Ports / NICs

The hardware Ports  
(e.g. SFP/Backhaul Ports)

**PNF Device**

FUTURE

**NF Component**

Sub-components within PNF

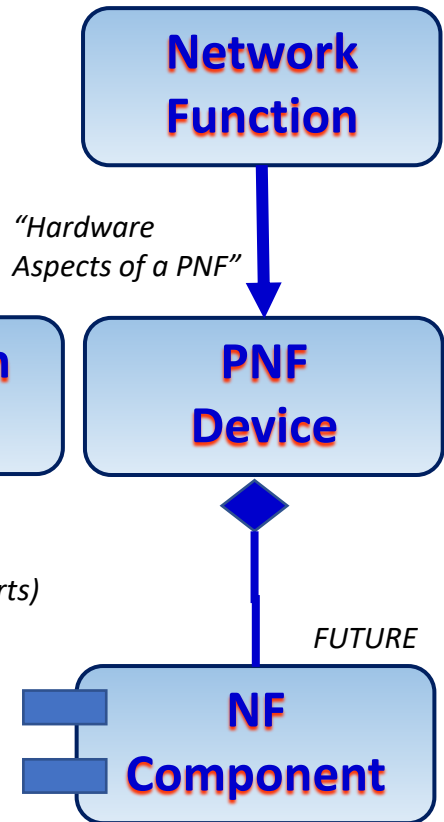

# DU Configurations

## DRIVE PARTITIONS

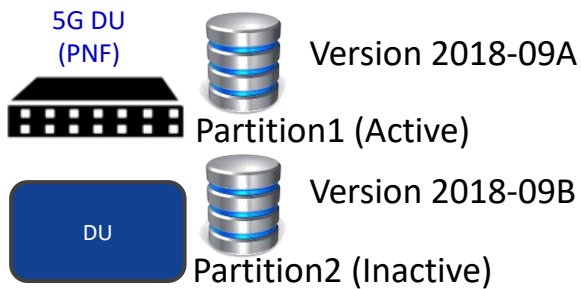

## SUBCOMPONENTS (R4+)

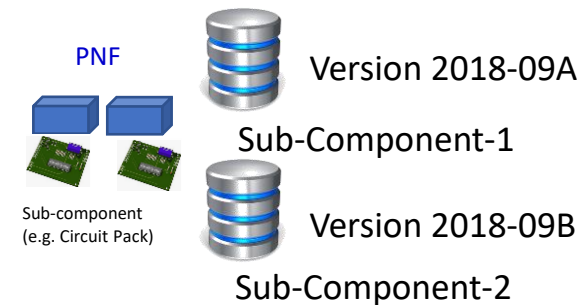

## MULTI-PNF DAISY CHAIN CONFIG

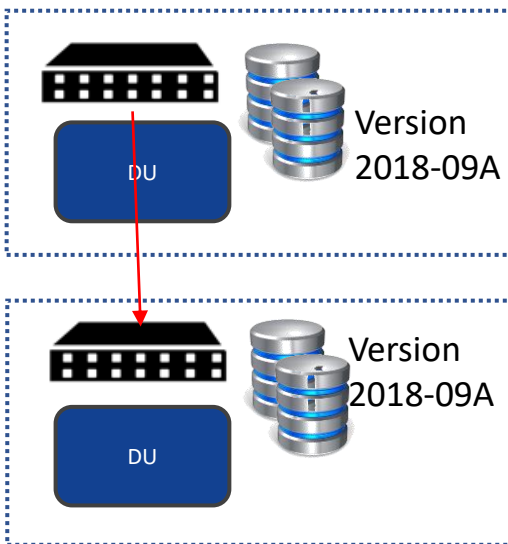

## TANDEM CHASSIS CONFIGURATIONS

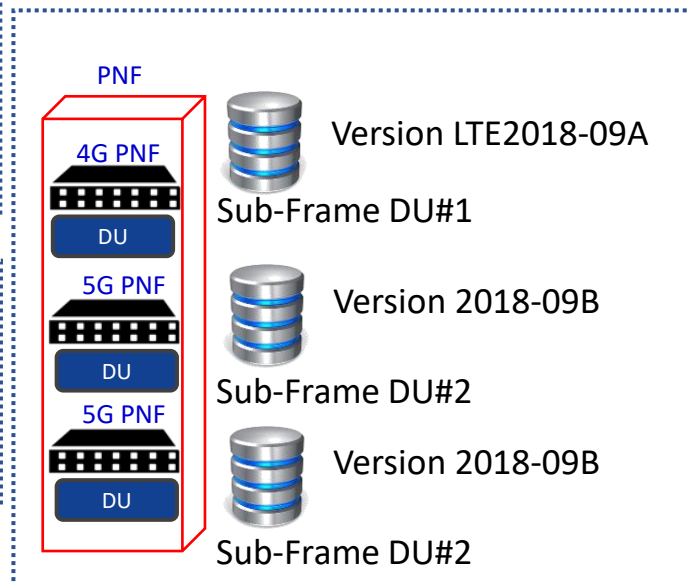



ETSI (SOL 001, SOL 004, SOL005, SOL 007)



Benjamin Cheung, PhD

# ETSI SOL Standards

Design Time

Run Time

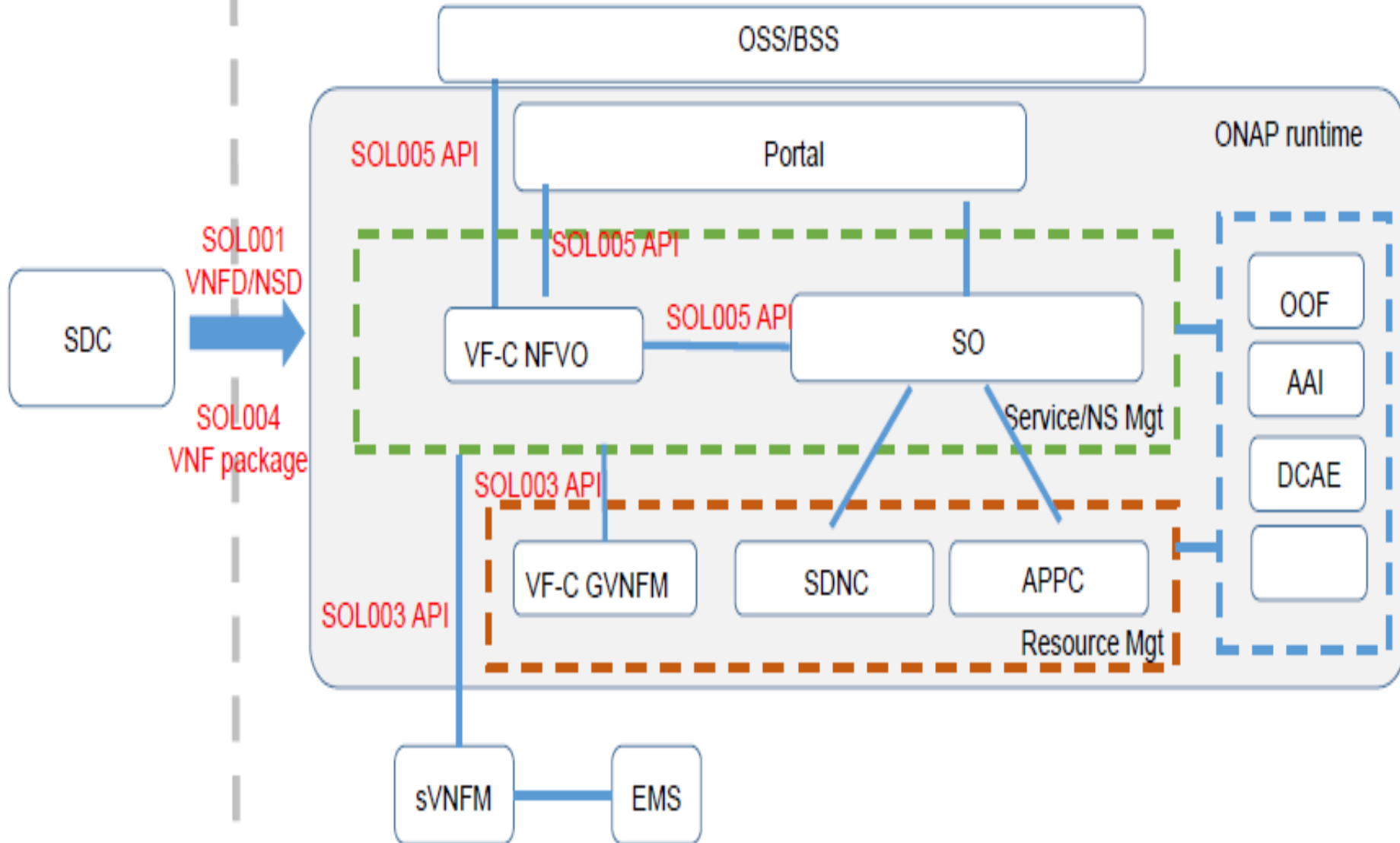

# ETSI SOL Standards Alignment

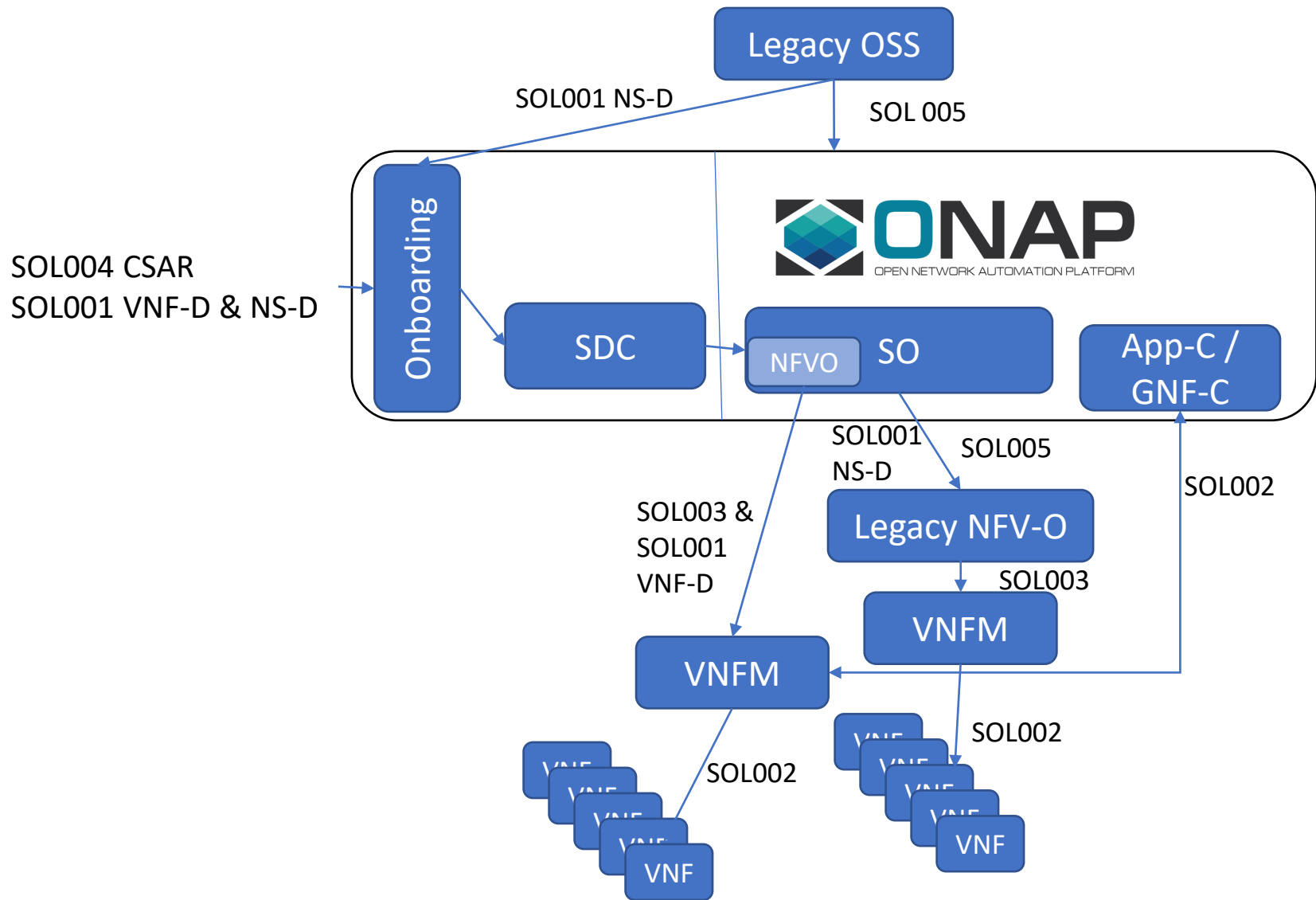



# VNFD/PNFD/NSD PROPERTIES ALIGNMENT

On-going ETSI discussion

PNFD	VNFD	NSD	Comments
descriptor_id	descriptor_id	descriptor_id	
version	descriptor_version	descriptor_version	Proposed new name in PNFD: <b>descriptor_version</b>
provider	provider	provider	
name	product_info_name	name	Better to be aligned. Proposed new name in VNFD: <b>name</b>
-	software_version	software_version	<p><b>New in PNFD</b></p> <ol style="list-style-type: none"> <li>1. Better to align with VNFD. VNFD uses <b>software_version</b> for only software change. <b>descriptor_id</b> might be changed only due to descriptor evolution itself like security adding.</li> <li>2. Long-term view, it would be useful to upgrade PNF software.</li> <li>3. It is also useful for service provider to get such information for OAM view like trouble-shooting, service checking, PNF packability checking and so on</li> <li>4. Align with ONAP model</li> </ol>
function_description	product_info_description	-	Proposed new name in VNFD: <b>function_description</b> .
descriptor_invariant_id	product_name	invariant_id	Add <b>function_description</b> into NSD
geographical_location_info	-	-	Proposed new name in VNFD / PNFD: <b>invariant_id</b>

# SOL004 EXPANDED SCOPE OPTION

On-going ETSI discussion

- Tentative updated SOL004 title :  
“Network Functions Virtualisation (NFV) Release 2; Protocols and Data Models; VNF Package specification **and PNF file specification**”
- Tentative updated scope:  
The present document specifies the structure and format of a **VNF** package file and its constituents, fulfilling the requirements specified in ETSI GS NFV-IFA 011 [1] for a VNF package **and in ETSI GS NFV-IFA 014 [x] for a PNFD**.
- Working schedule:

<u>Milestone name</u>	<u>Target date</u>
• CR approval with expanded scope of 2.6.1	2018/12/07
• Functional CRs approved	2018/12/13
• WG approval	2018/12/31
• TB approval	2019/01/31

- General
- Deployment Artifact**
- Information Artifact
- TOSCA Artifacts
- Composition
- Operation
- Activity Log
- Deployment
- Properties Assignment

## Deployment Artifact

Name	Type	Deployment timeout	Version	UUID	
VF License	VF_LICENSE		1	e6e2400c-a2de-483f-acd1-c31acba7ef46	<a href="#">↓</a>
base_vfw	HEAT	60	2	1622eb22-0902-4468-079e-23f4dfed4c4f	<a href="#">↓</a>
VF HEAT ENV	HEAT_ENV		0		<a href="#">↓</a>
Vendor License	VENDOR_LICENSE		1	08c22b3a-6087-46ee-0192-af9399491239	<a href="#">↓</a>

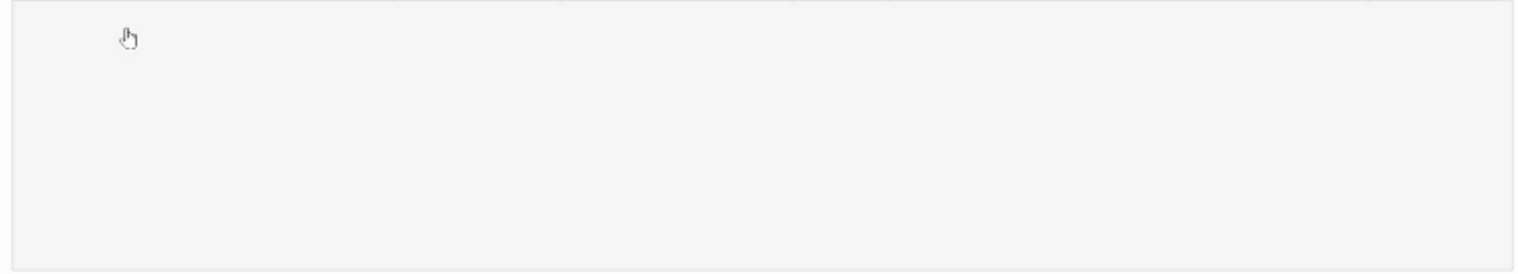

Deployment Artifact

Name	Type	Deployment timeout	Version	UUID	
VF License	VF_LICENSE		1	e6e2400c-a2de-483f-act1-c31acba7ef46	<a href="#">↓</a>
base_vfw	HEAT	60	2	1622eb22-0902-4468-079e-23f4dfe4c4f	<a href="#">↓</a>
VF HEAT ENV	HEAT_ENV		0		<a href="#">↓</a>
Vendor License	VENDOR_LICENSE		1	08c22b3a-6087-46ee-9192-af9399491239	<a href="#">↓</a>

General

**Deployment Artifact**

Information Artifact

TOSCA Artifacts

Composition

Operation

Activity Log

Deployment

Properties Assignment

```

171 networks:
172 - network: { get_param: public_net_id }
173 - port: { get_resource: vfw_private_0_port }
174 - port: { get_resource: vfw_private_1_port }
175 - port: { get_resource: vfw_private_2_port }
176 metadata: {vnf_id: { get_param: vnf_id }, vf_module_id: { get_param: vf_module_id }}
177 user_data format: RAM
178 user_data:
179 str_replace:
180 params:
181   __dcae_collector_ip__ : { get_param: dcae_collector_ip }
182   __dcae_collector_port__ : { get_param: dcae_collector_port }
183   __repo_url_blob__ : { get_param: repo_url_blob }
184   __repo_url_artifacts__ : { get_param: repo_url_artifacts }
185   __demo_artifacts_version__ : { get_param: demo_artifacts_version }
186 template: |
187   #!/bin/bash
188
189   DCAE_COLLECTOR_IP=__dcae_collector_ip__
190   DCAE_COLLECTOR_PORT=__dcae_collector_port__
191   REPO_URL_BLOB=__repo_url_blob__
192   REPO_URL_ARTIFACTS=__repo_url_artifacts__
193   DEMO_ARTIFACTS_VERSION=__demo_artifacts_version__
194
195   # Download required dependencies
196   add-apt-repository -y ppa:openjdk-r/ppa
197   apt-get update
198   apt-get install -y make wget openjdk-8-jdk gcc libcurl4-
199   apt-get install -y maven
200   pip install jsonschema
201
202   # Download vFirewall code for virtual firewall
203   mkdir /opt/config
204   mkdir /opt/honeycomb
205   cd /opt
206   wget $REPO_URL_BLOB/org.openecomp.demo/vnfs/vfw/$DEMO_ARTIFACTS_VERSION/v firewall_init.sh
207   wget $REPO_URL_BLOB/org.openecomp.demo/vnfs/vfw/$DEMO_ARTIFACTS_VERSION/vfirewall.sh
208
209   mvn org.apache.maven.plugins:maven-dependency-plugin:2.10:get -DremoteRepositories=$REPO_URL_ARTIFACTS
210   -Dartifact=org.openecomp.demo.vnf:sample-distribution:$DEMO_ARTIFACTS_VERSION:tar.gz:hc -Dtransitive=false -Ddest=.
211   mvn org.apache.maven.plugins:maven-dependency-plugin:2.10:get -DremoteRepositories=$REPO_URL_ARTIFACTS -Dartifact=org.openecomp.demo.vnf:ves:ves:$DEMO_ARTIFACTS_VERSION:tar.gz:
212   -Dtransitive=false -Ddest=.
213   mvn org.apache.maven.plugins:maven-dependency-plugin:2.10:get -DremoteRepositories=$REPO_URL_ARTIFACTS
214   -Dartifact=org.openecomp.demo.vnf:ves:ves_vfw_reporting:$DEMO_ARTIFACTS_VERSION:tar.gz:demo -Dtransitive=false -Ddest=.
215
216   tar -zxvf ves-$DEMO_ARTIFACTS_VERSION-demo.tar.gz
217   mv ves-$DEMO_ARTIFACTS_VERSION VES
218   tar -zxvf ves_vfw_reporting-$DEMO_ARTIFACTS_VERSION-demo.tar.gz
219   mv ves_vfw_reporting-$DEMO_ARTIFACTS_VERSION VESreporting_vfw
220   tar -zxvf sample-distribution-$DEMO_ARTIFACTS_VERSION-hc.tar.gz
221   mv sample-distribution-$DEMO_ARTIFACTS_VERSION honeycomb

```

Find dialog box showing search options. The search text is "vc". The "Find Next" button is highlighted. The status bar at the bottom of the dialog says "Find: Found the 1st occurrence from the top. The end of the document has been reached."

certificates

Just in time instantiation of resources

VNFD

U/C deploy VNFC in K8S dynamically provision the platform.

NFaaS

Inventory; order, capacity

RACK of H/W

redfishAPI, RestFUL API envelope of specification (TOSCA)

Declarative,

Physical infrastructure manager

















Multicloud layer

IaaS , Service based style-guide

AWS Azure

PNF Box, NF, composition API dynamically created.

Scarce res composable infrastructure multi-tenancy. Compose/r

-   Ben Cheung (me)
-   YURIY MALAKOV (Host)
-   Alexis de Talhouët
-   Call-in User\_2
-   DAN TIMONEY
-   Lalena Aria
-   Marc-Alexandre Choquette
-   Ofir Sonsino
-  Oskar Malm

## SDC Internal Package

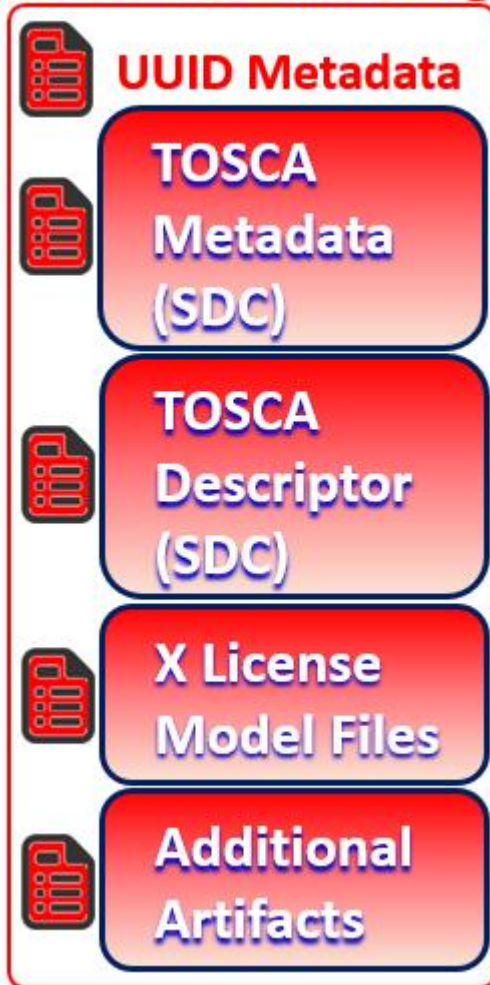

## SDC Internal Package

