



Orchestration for Edge-Computing (WIP) - Background work to identify gaps

For more information

Edge-Automation group in ONAP

Contact: Srinivasa.r.addepalli@intel.com on this presentation

Network E2E (5G – An Edge computing enabler)

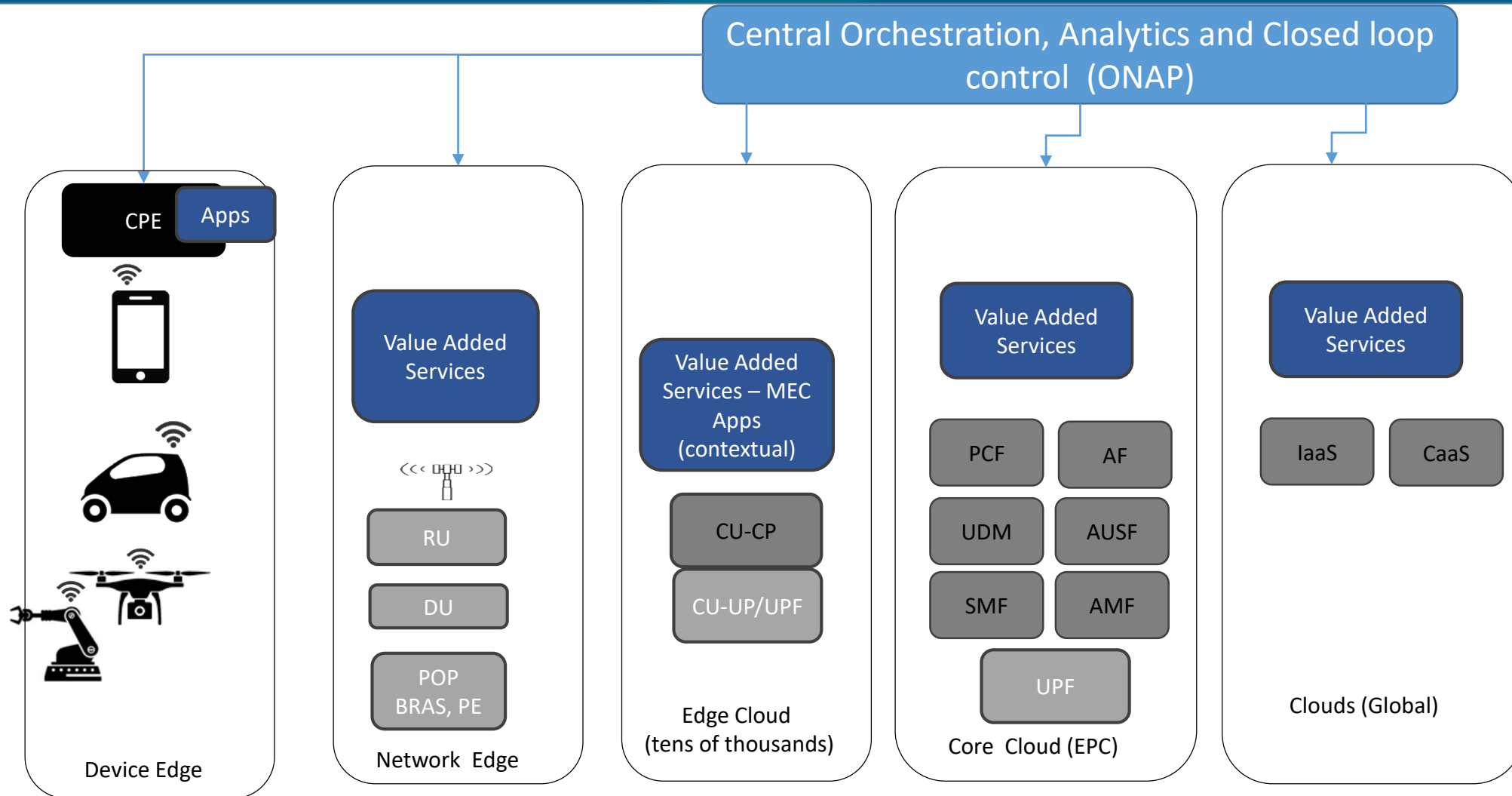

Initial focus of Industry – Edge Cloud support for Edge-computing

Why Edge?

Massive Data from/to Devices – Data Reduction to Clouds

(Upstream : Data from Drones, Autonomous vehicles, factories
Downstream : 4K Streaming, AR/VR, Sports Casting, Live Gaming)

Real time and Ultra real time performance

(Closed loop control in case of IOT, On-demand compute for AR/VR, Live Gaming etc...)

Contextual Services

(User based Services, Location based Services)

Edge Requirements (to ONAP)

Scalability

(Ability to address large number of Edge Clouds, switches at Edges, Support various edge controller technologies)

Security

(Infrastructure verifications, Securing secrets/keys)

Regulations

(Keep data local, GDPR – Encrypt all user data at storage/memory/on-wire)

Performance in Constrained Environment

(Very low latency, High performance, Performance determinism, data reduction, Lesser utilization of resources)

Zero touch provisioning

(Faster bring up of Edge Clouds, Easy upgrades)

Edge App provisioning

(Traffic Redirection, Providing contextual information, slice aware)

ONAP Enhancements to support Edges – Summary

(Green in Started in R3, Red – start in R4 and rest later)_

Edge Requirement	ONAP Changes (WIP)
Scalability	<i>Optimization needed to address large number of edge-clouds – Edge Cloud Provider - Parent-Child ONAP (Distributed/Delegated – domain orchestration), Fabric Control, Closed loop</i>
Security	Mutual TLS with Edges, Secrets/keys protection (HSM/DHSM), Hardware rooted security, Verification of Edge stack (Attestation), Centralized security for FaaS.
Regulations	GDPR – Symmetric keys protection, KMS at ONAP Placement decisions based geography location.
Performance	Containerized VNFs (ONAP talking to K8S based Edge Clouds) SRIOV-NIC, FPGA-NIC support (HPA++) – Enhancements needed in ONAP, Fabric Control
Edge App provisioning (MEC or others)	<i>ONAP to expose API for Application providers – to create MEC Service, instantiate MEC Service, provide MEC status, MEC analytics etc... Integration with MEC Platform by creating MEC EMS in ONAP. Use NEV SDK as MEC platform (as VNF – Container/VM)</i>
Zero Touch provisioning (Install/Update)	Ability for ZTP systems to interact with ONAP to provide information about Edge inventory. <i>Edge connectivity (using private IP addresses)</i>
Network Slicing/PNF provisioning (5G use case requirements), Optimization constraints support, SON integration	Being addressed in 5G use case group.
Container & VM & FaaS deployments	Unified networking (OVN/Contiv CNI) support from ONAP Support for FaaS platforms (OpenWhisk, OpenFaaS, Kubeless, Fn etc...) Modeling enhancements to support container and FaaS workloads
Analytics	Aggregation of statistics & ML analytics for various edge deployments and provide infrastructure information to application providers.



ONAP

OPEN NETWORK AUTOMATION PLATFORM

Scalability – Hierarchical
Federation

Edge Deployment Architecture – ONAP for Service Orchestration

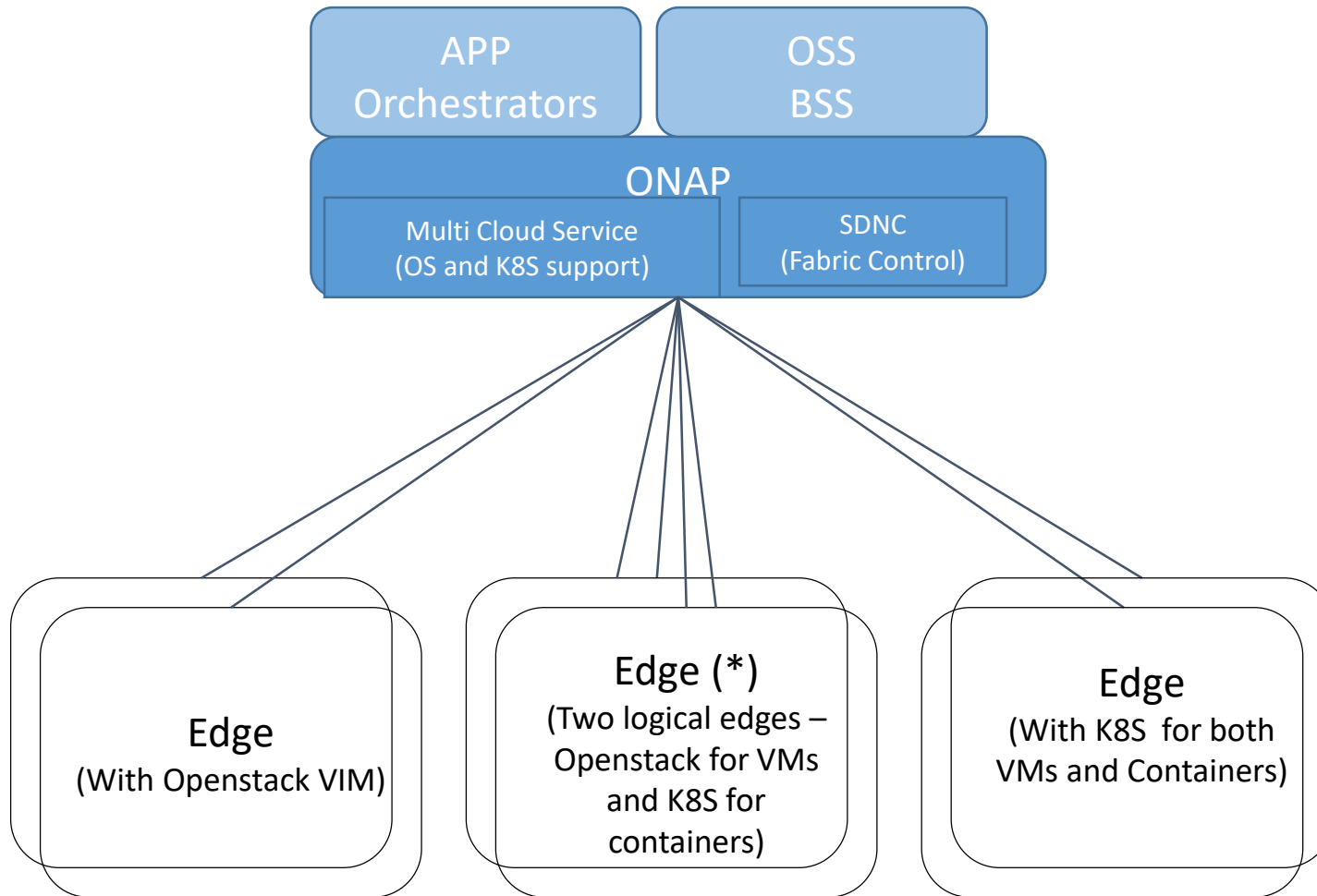

- Support for both Openstack based Edges and K8S based Edges.
- Support for K8S based Edges that do both VM and Container VNF management
- Fabric Control to manage switch (Manage Stratum, dNOS based switches)

- Challenges
 - Can it handle large number of edges?
--> Automation Offload Platform at different sites.

Edge Deployment Architecture – ONAP + Akraino

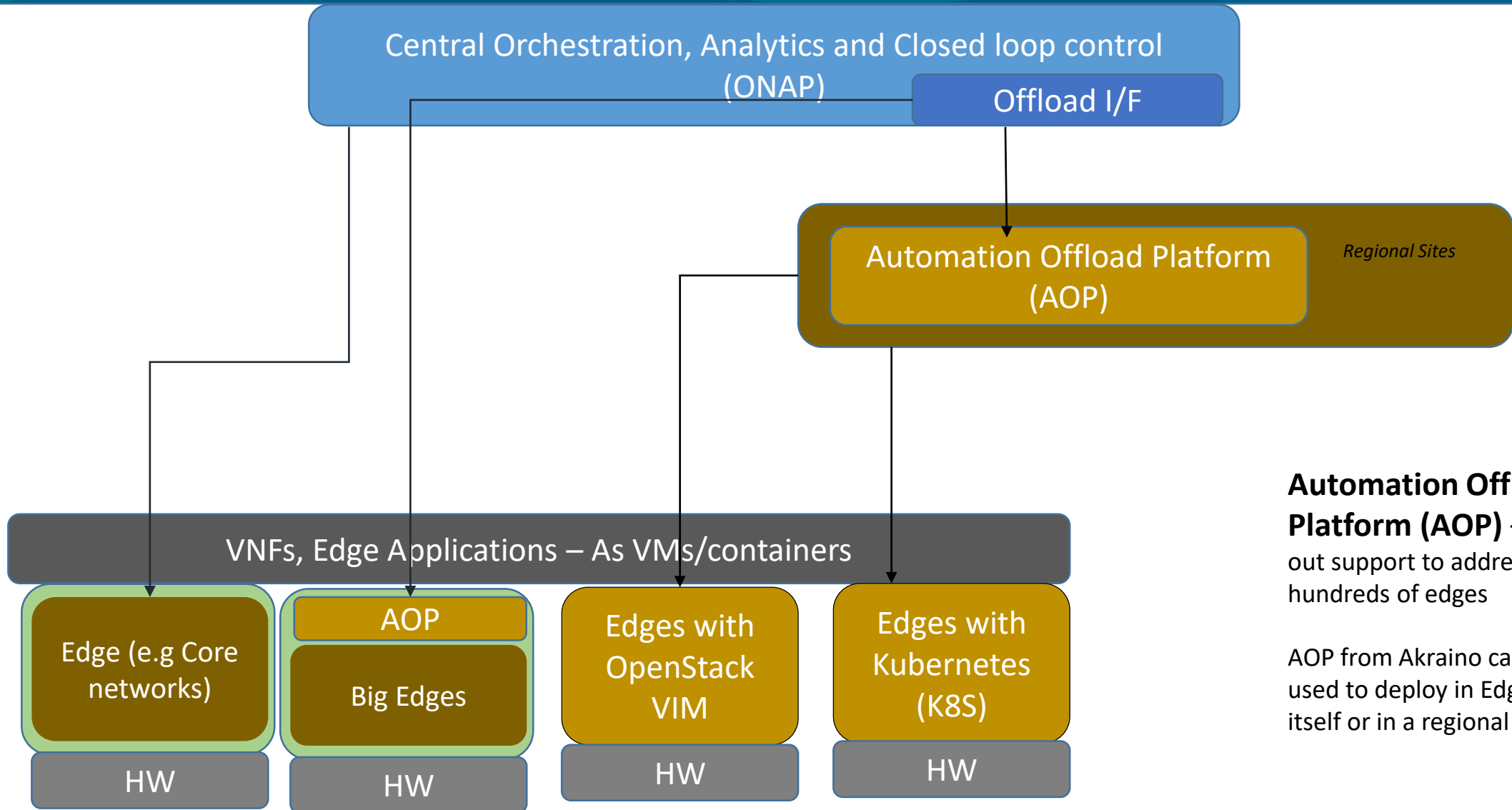

Automation Offload Platform (AOP) – Scale-out support to address hundreds of edges

AOP from Akraino can be used to deploy in Edge site itself or in a regional site.

ONAP - Edge scalability

ONAP and Edge-Scalability (Addressing 1000s of Edge Clouds)_

- Support for various VIMs (eg. **Akraino**, Openstack, **K8S**, *VIO*, *Titanium*, *Azure*, *AWS* etc..)
- Tune/Enhance – for performance
 - Hierarchical Federation: Site-level orchestration, Fabric control, Gateway control, Analytics, Topology discovery and capability distribution
 - Placement decisions across thousands of Edges (eg. OOF, Multi-Cloud)
 - Discovery of Edges and edge capabilities
 - Fault/Alarm/Statistics collection agents
 - Service scale-out
 - Database limitations
- Usability/Simplicity
 - Auto registration : Avoid manual addition & Deletion of each Edge (Collaboration between ONAP and Akraino)
- Fabric Control (Controlling L2/L3 physical switches for VLAN/VXLAN/QoS/Policies, mainly for SRIOV-NIC VNFs)
 - Collaboration between ONAP and Akraino.
 - Take advantage of Stratum project and avoid new plugins in AOP & ONAP
- Fault/Alarm/Statistics Collection
 - Collaboration between ONAP and Akraino to define Data models and protocols, RESP

Edge Deployment Architecture – Offload Interface points

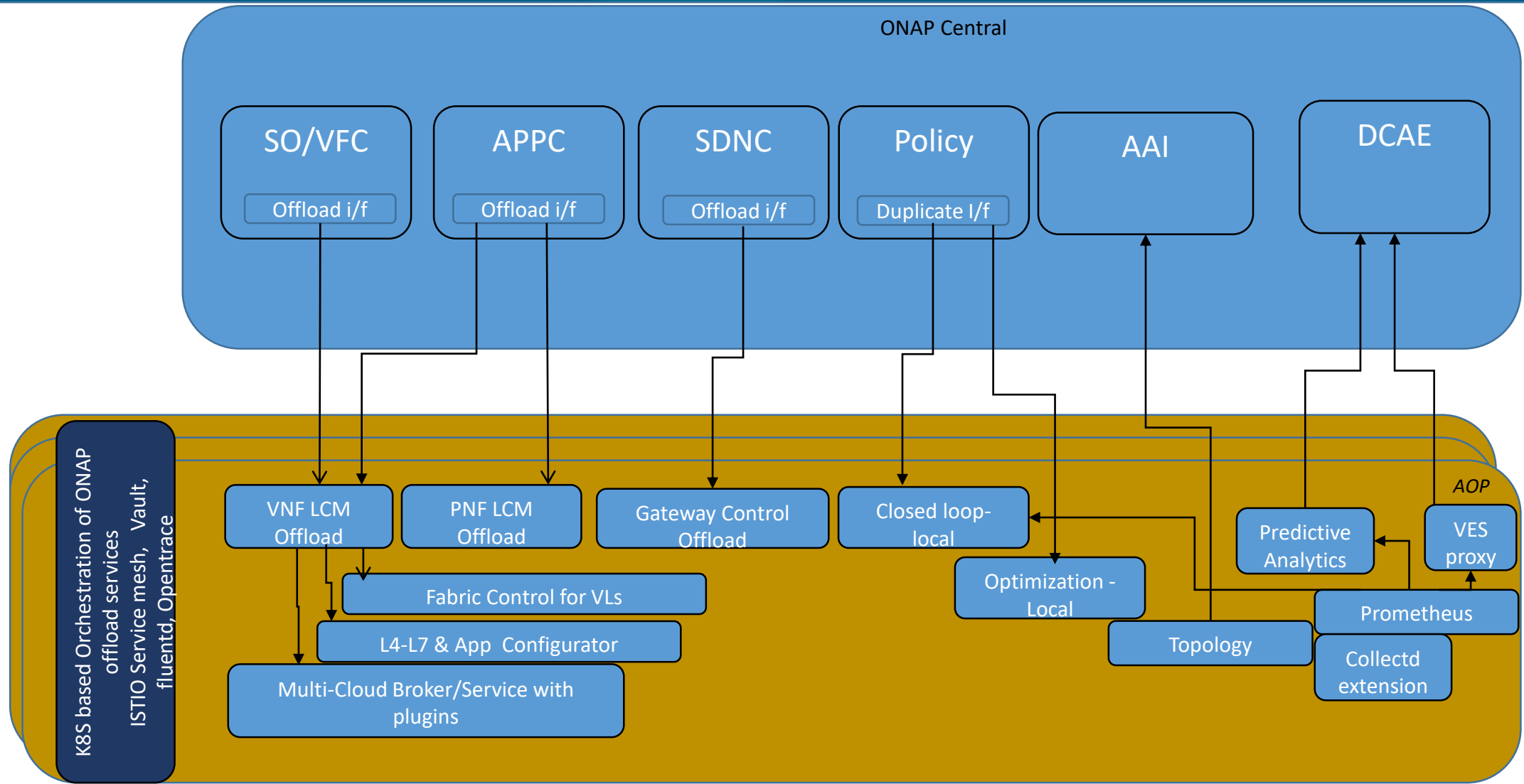

Hierarchical Federation – Site registration

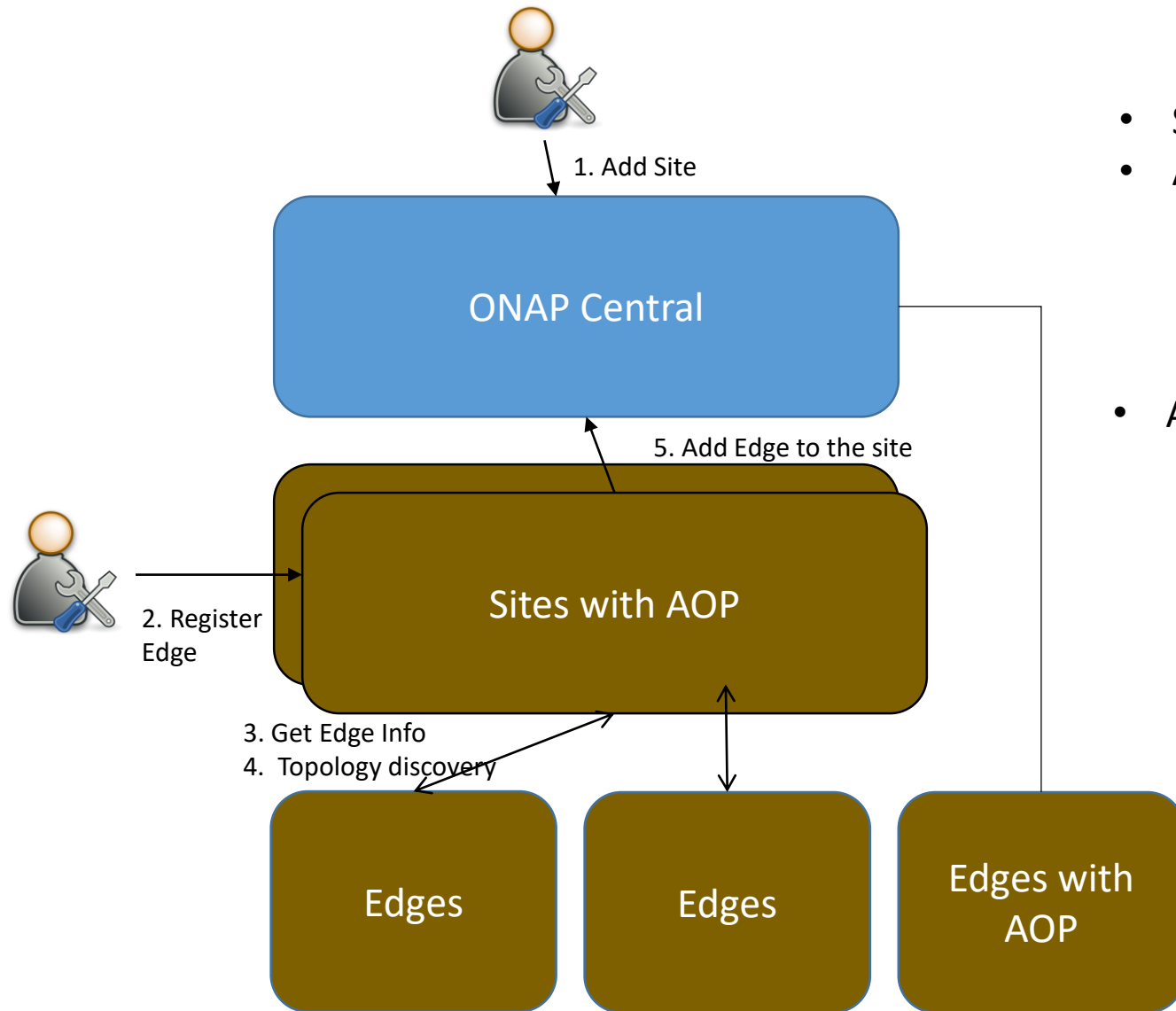

- Sites are added to Central ONAP by administrator
- AOP adds information about edges to the Central ONAP

- AOP collects information about Edges
 - HPA information
 - Fabric topology and Fabric element capacity

Projects: A&AI
AOP Topology Project – Leverage
A&AI software

Hierarchical Federation – VNF LCM

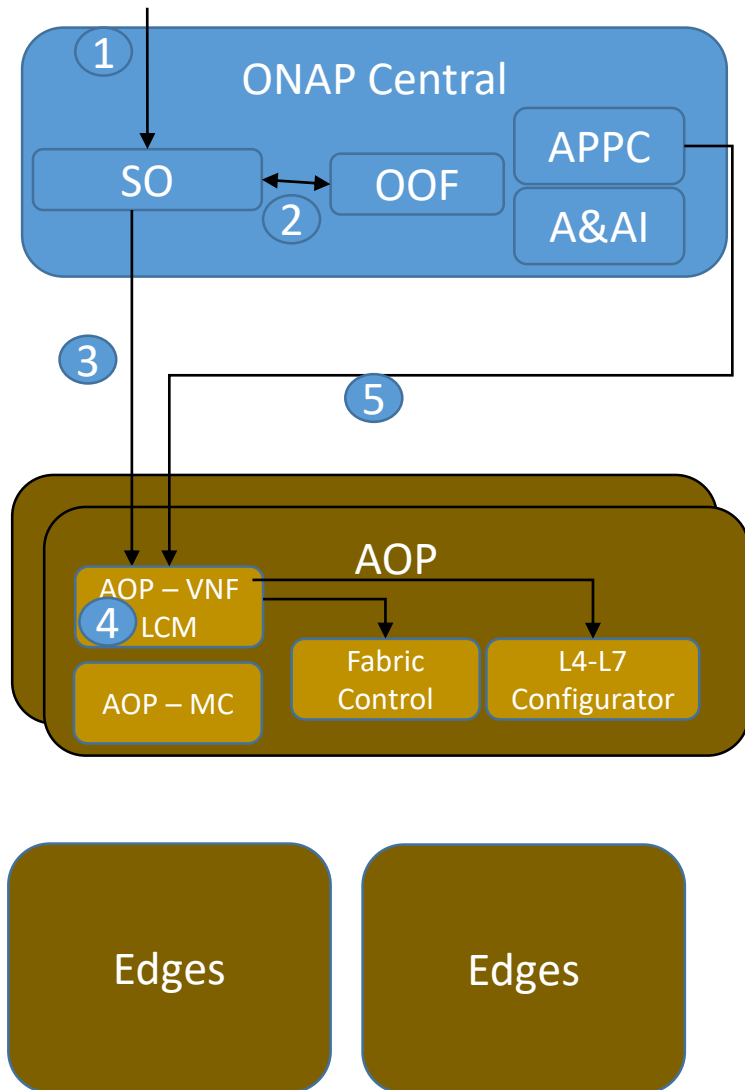

1. Service instantiation request (SO decomposes NSD)
2. For each VNFD, SO requests OOF to get the best sites to place VNF and get the edges that can host VNF. Modifies VNFD and VLs with the information from OOF. Also sends any artifacts related to VNF LCM such as initial configuration data
3. SO finds the Site that controls Edge and sends modified VNFD and VLs (in TOSCA) to AOP
4. AOP-VNFLCM decomposes VNFD & VLs from TOSCA and uses AOP-MC to bring up workloads and Fabric control to program the switches in the edge. Also via L4-L7 configurator, it configures VNF applications.
5. APPC sends any configuration update to AOP

AOP also does monitoring, Healing, Scale-out, migration on existing VNFCs

AOP informs SO if it can't do any part of LCM

Projects: SO, APPC

Networking – Fabric Control

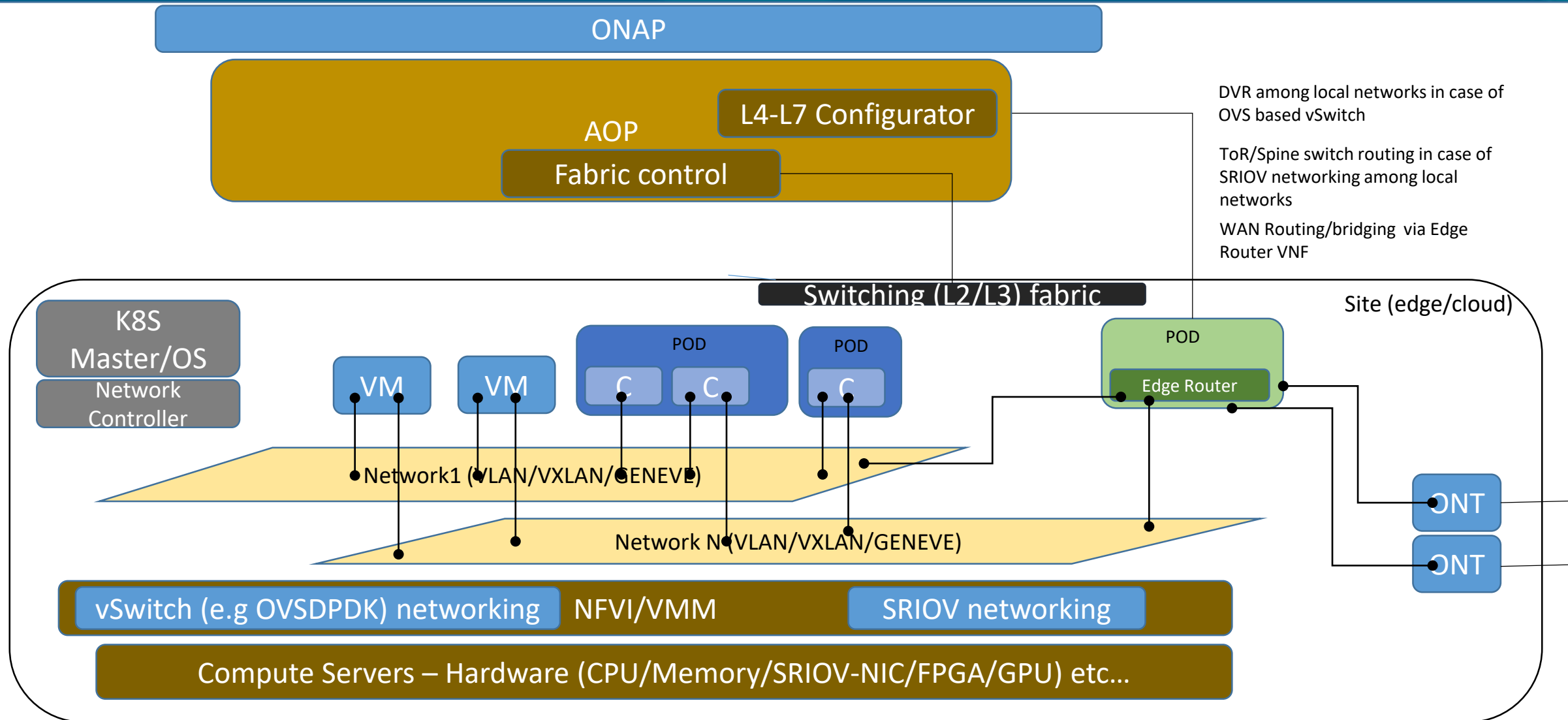

Scalability - Casablanca

- Fix any scalability issues in ONAP – Ongoing
 - Benchmarking (with at least 100 Edge Clouds)
 - Fix any gaps/issues
- Define ONAP-AOP Interfaces
- Define architecture of AOP.
 - Identify common components.
 - Identify new components to be developed.
- Stretch Goal:
 - VNF LCM



ONAP

OPEN NETWORK AUTOMATION PLATFORM

Security

Security – ONAP Enhancements

Security requirements & ONAP enhancements

- Mutual TLS on every communication between ONAP and Edges
 - Enhancements at Multi-Cloud layer & DCAE
- Certificate Enrollment
 - CA Instance that provides certificates for Edges
 - Auto Certificate enrollment (Ability for CA to verify the Edges)
- Certificate Private key protection using PKCS11 at Edge nodes
 - ONAP CA to wrap the certificate private key using public key of Edge TEE(eg. TPM) – Joint initiative/project between ONAP and Akraino
- ONAP supplied Secret/Passwords protection at Edge nodes
 - ONAP to provide a way to wrap passwords using public key of Edge TEE – Joint initiative/project between ONAP and Akraino
- Software tamper detection of Edges and blacklisting edges
 - Software/firmware/hardware attestation at the ONAP – Joint project between ONAP and Akraino
- Security analytics – Joint project between ONAP/Akraino



ONAP

OPEN NETWORK AUTOMATION PLATFORM

Regulations

Regulations – ONAP Enhancements

Regulation requirements & ONAP enhancements

- GDPR – Need for securing the data at Edges.
 - Encryption of data requires keys and keys should not be in storage.
 - Key Management Service at the ONAP to provide keys on demand basis
- Data placement restrictions/regulations
 - Enhance OOF with policies that specify data placement regulations
 - ONAP SO to place VNFs accordingly.



ONAP

OPEN NETWORK AUTOMATION PLATFORM

Performance

Performance – ONAP Enhancements

Performance requirements & ONAP enhancements

- Containerized VNFs
 - ONAP to control K8S based Edge-Clouds.
 - ONAP to use K8S for both VMs and container placement.
 - ONAP to allow specification of VNF (TOSCA) with both VMs and containers
- Support SRIOV Networking for performance determinism for highly real time applications
- Unified networking between VMs and ONAP (possible choices : OVN or Contiv)
- Multiple interfaces – Device tagging support in ONAP



ONAP

OPEN NETWORK AUTOMATION PLATFORM

Zero Touch Provisioning

Zero Touch Provisioning – ONAP Enhancements

Zero Touch Provisioning & ONAP enhancements

Auto Edge registration to ONAP – ZTP to help?



ONAP

OPEN NETWORK AUTOMATION PLATFORM

Edge App Provisioning

MEC Architecture

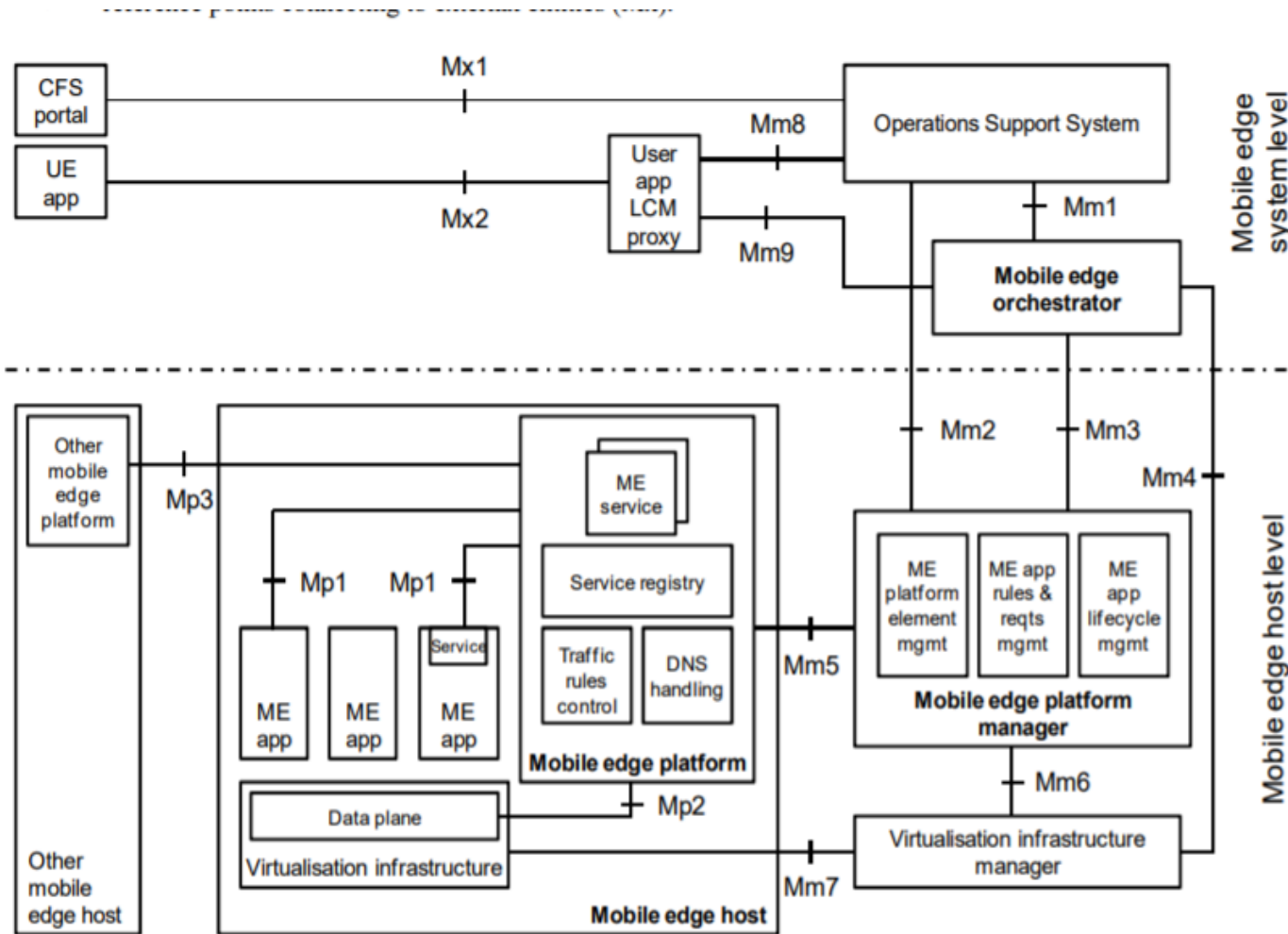

Figure 6-1: Mobile edge system reference architecture

MEC Specifications

- GS MEC 009: General Principles for Mobile Edge Service APIs
- GS MEC 012: Radio Network Information API
- GS MEC 013: Location API
- GS MEC 014: UE Identity API
- GS MEC 015: Bandwidth Management API
- GS MEC 016: UE Application Interface
- GS MEC 010: System, Host and Platform Management
- GS MEC 011: Mobile Edge Platform Application Enablement

Virtualization & Containers

- MEC027 – Container study
- MEC020 - NFV Study

Reference:

http://www.etsi.org/deliver/etsi_gs/MEC/001_099/003/01.01.01_60/gs_MEC003v010101p.pdf

MEC Architecture – Challenges (in 4G)

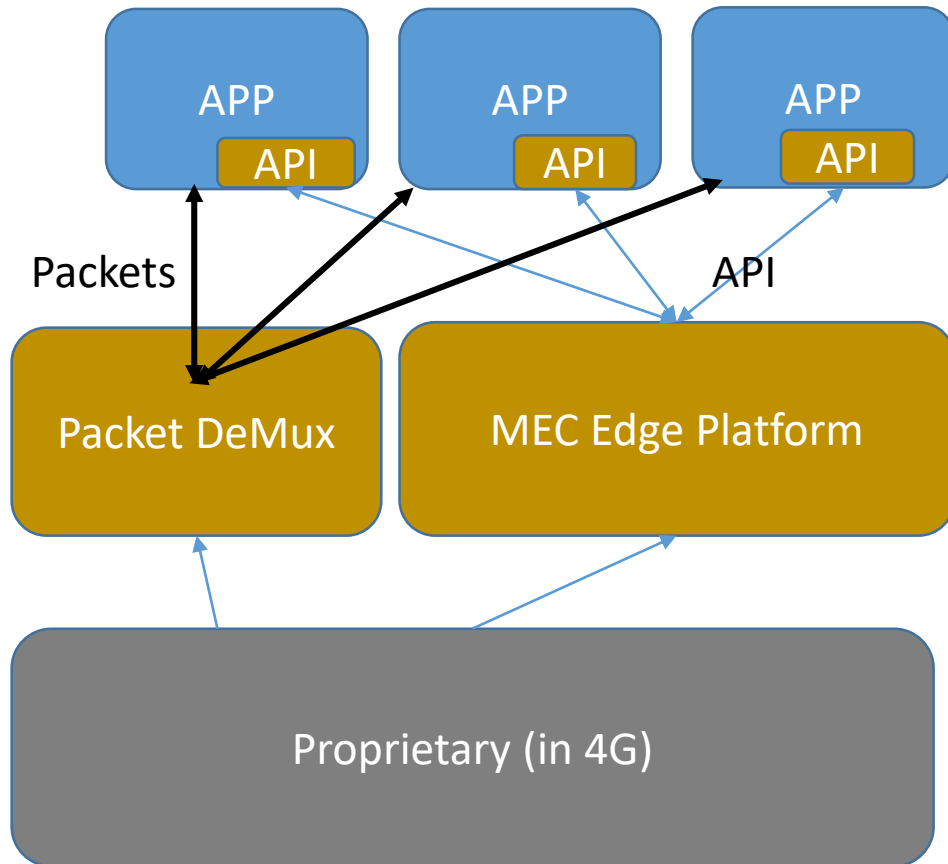

MEC has decent RESTful API definition to provide contextual information

4G challenges

- No standard way to provide contextual information to MEC edge platform.
- No standard way to De multiplex the UL traffic and aggregate DL traffic.

5G and MEC

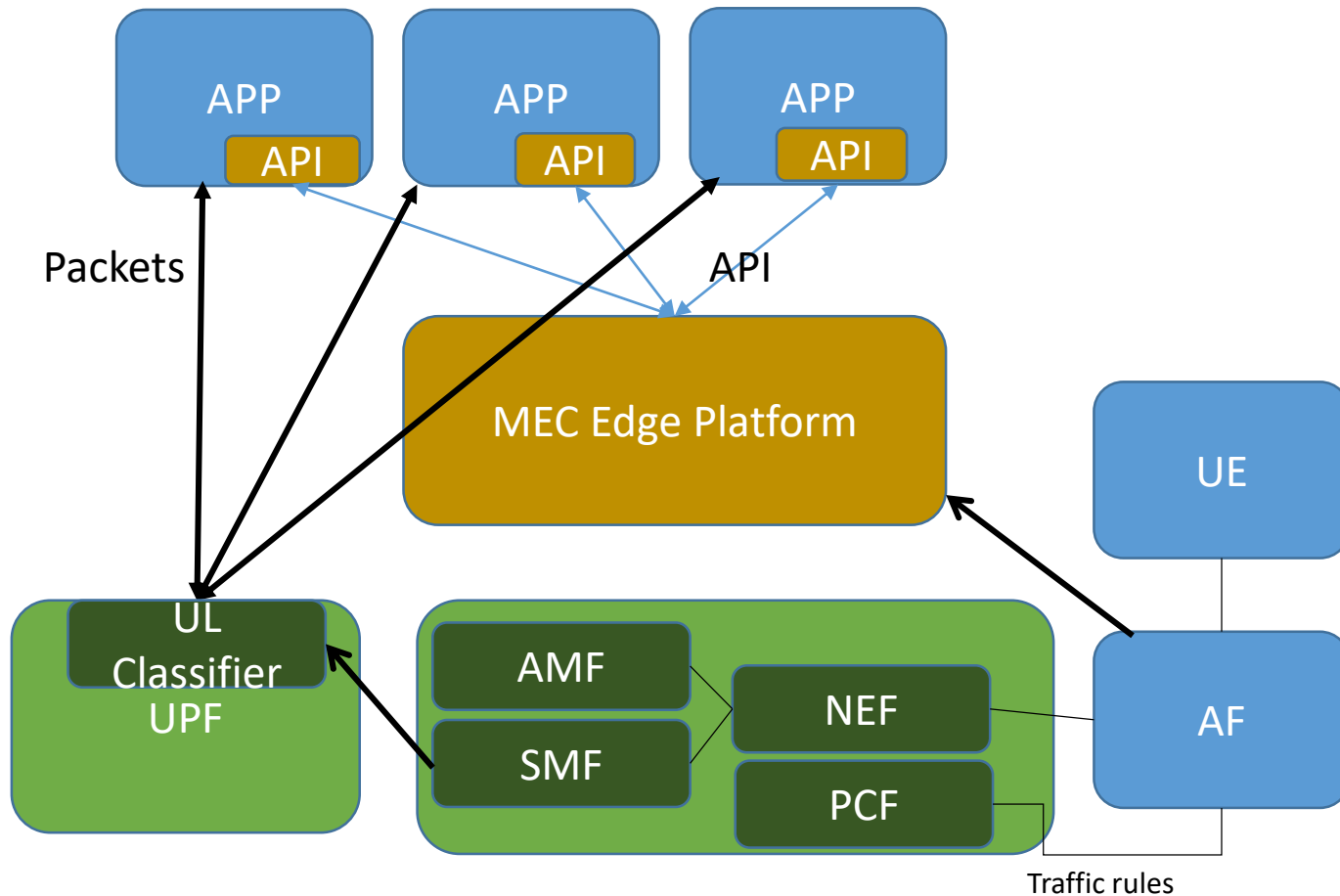

5G is defining standard way to redirect the traffic (SMF and UPF).

5G is also defining standard way to get hold of contextual information (AMF and SMF with NEF).

Mobile Edge Platform VNF can be a translator between 5G exposed information to APPs that use MEC API to get contextual information.

MEC Application Provider and ONAP deployments – Choice 1 (ONAP-Managed Edge App provisioning)

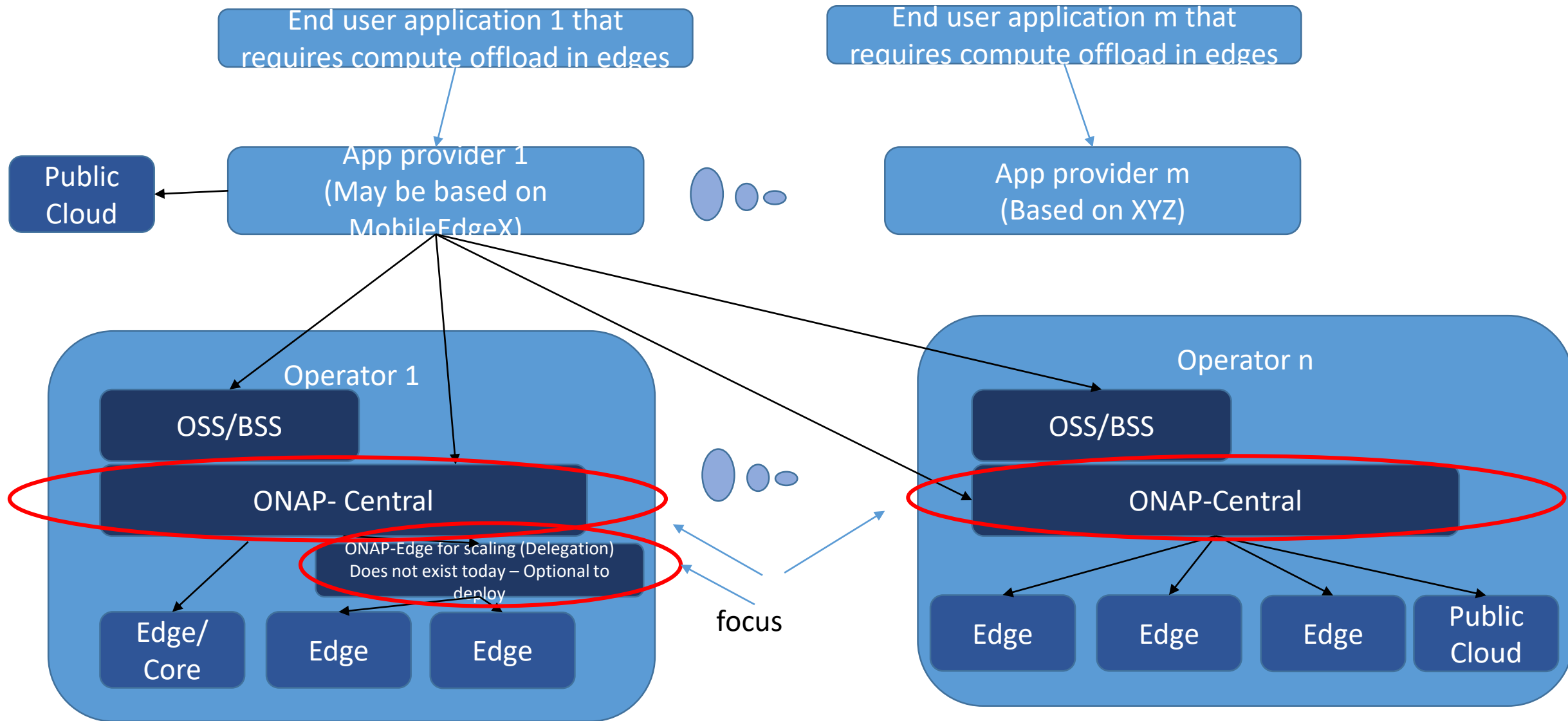

Edge Application use case – Compute offload by User Entity

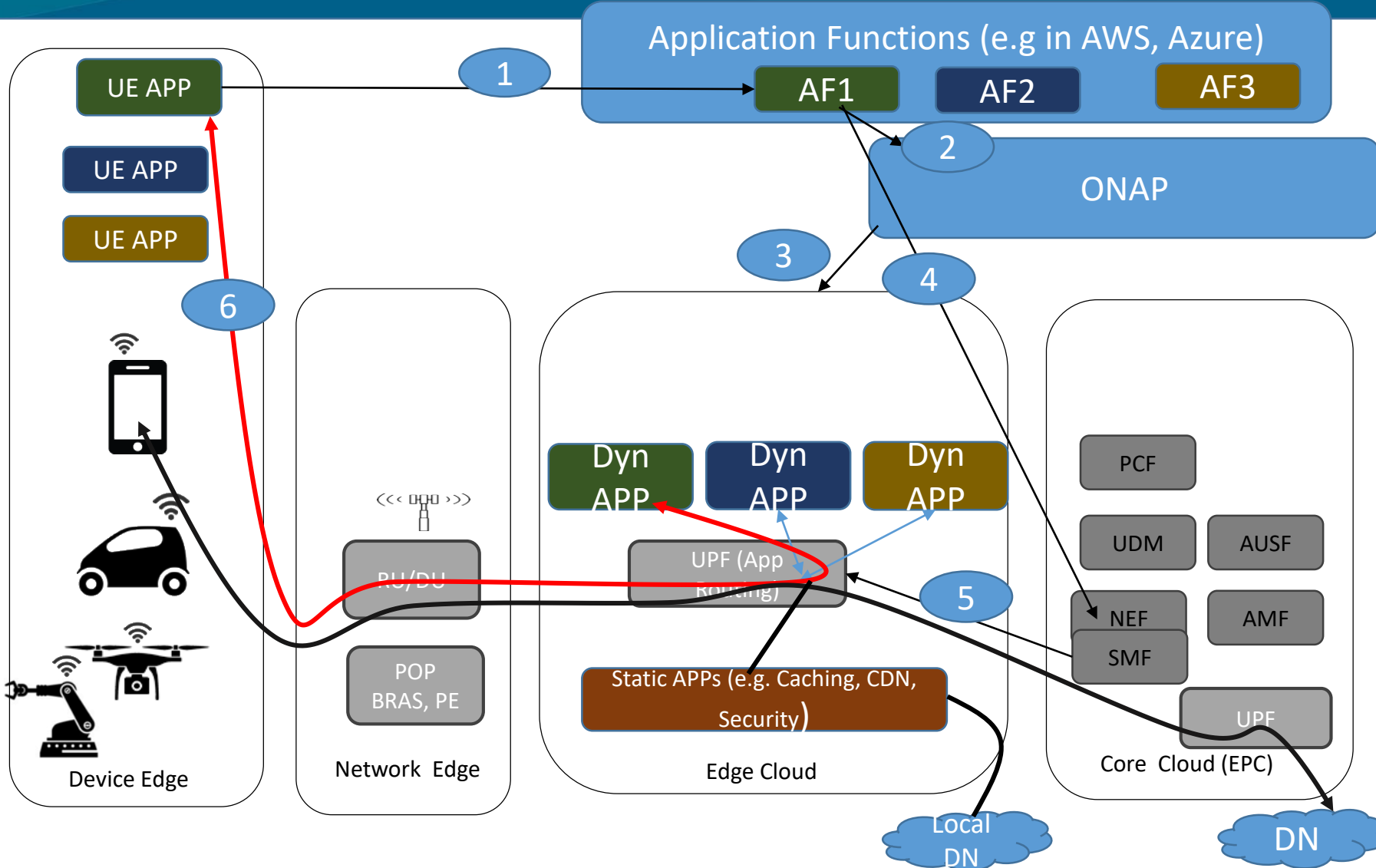

1. UE APP requests AF to create compute for it (e.g. AR/VR, Gaming offload). UE provides information such as 'coordinates', 'max cost', 'max latency', etc...
2. AF requests ONAP to create DynApp (can be a VNF too) in closest edge that satisfies UE requirements (ONAP figures out the best region out of thousands of clouds).
3. ONAP brings up DynApp/VNFs on the Edge Cloud using VIM API
4. AF informs NEF/SMF to create traffic rule (to enable redirection of UE APP traffic to newly-created VNFs).
5. SMF informs UPF in the edge cloud (i.e., programs UE classifier of UPF).
6. Traffic from a UE app is directed to the correct edge cloud app.

Network E2E with Edge Apps – MEC Apps & Contextual information

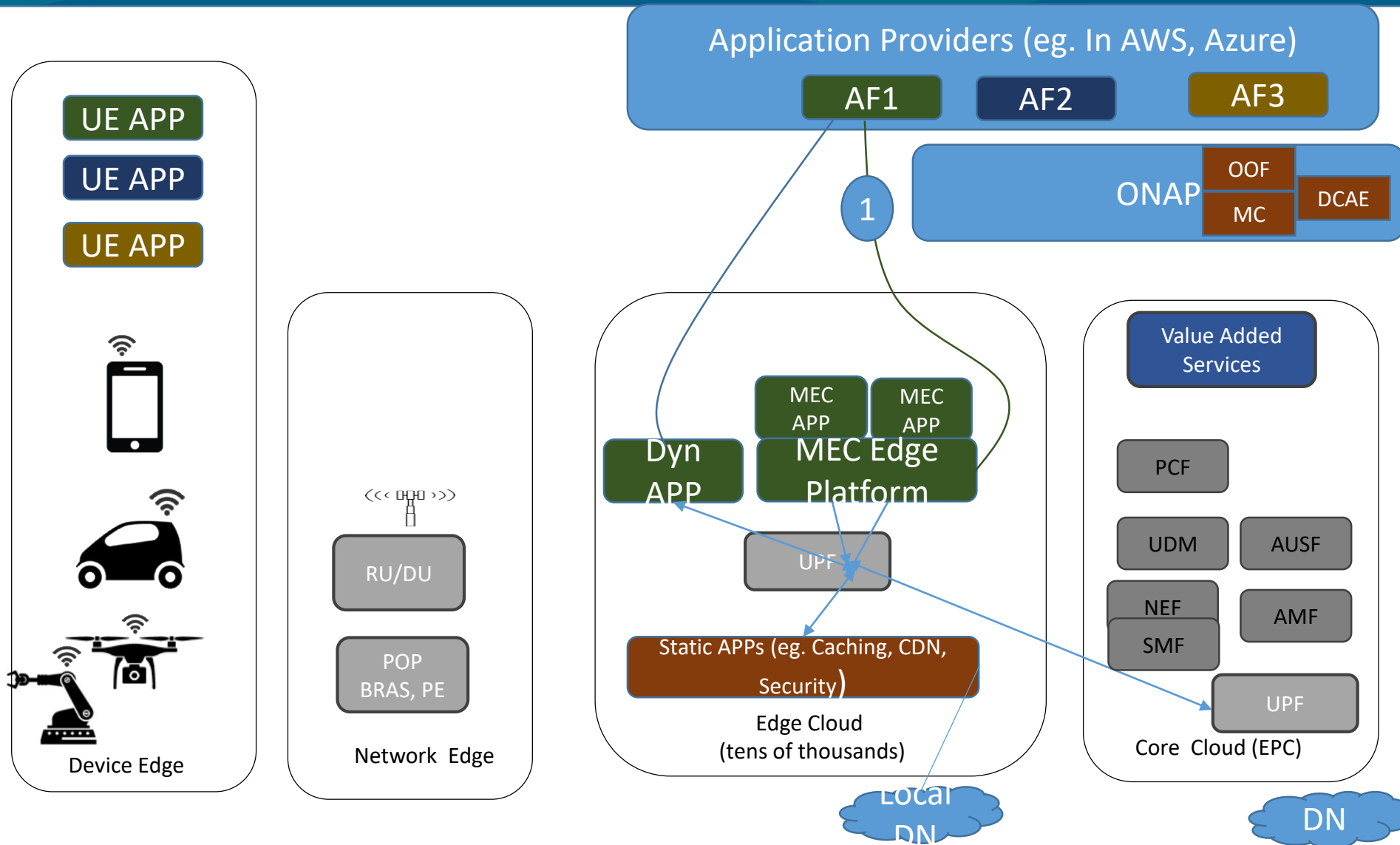

- Dyn Apps get contextual information from AFs.
 - Legacy MEC Applications can be supported.
1. AF can get the information from SMF and AMF (location, Subscriber ID and others) and make it available to “MEC Edge Platform”. MEC Edge Platform can in turn expose this information via ETSI MEC API

Question: Do we see MEC Edge platform by each application provider? Or one platform for entire edge by operator? Or support both cases?

MEC Application Provider and ONAP deployments – Choice 2 (ONAP-unaware Edge App provisioning)

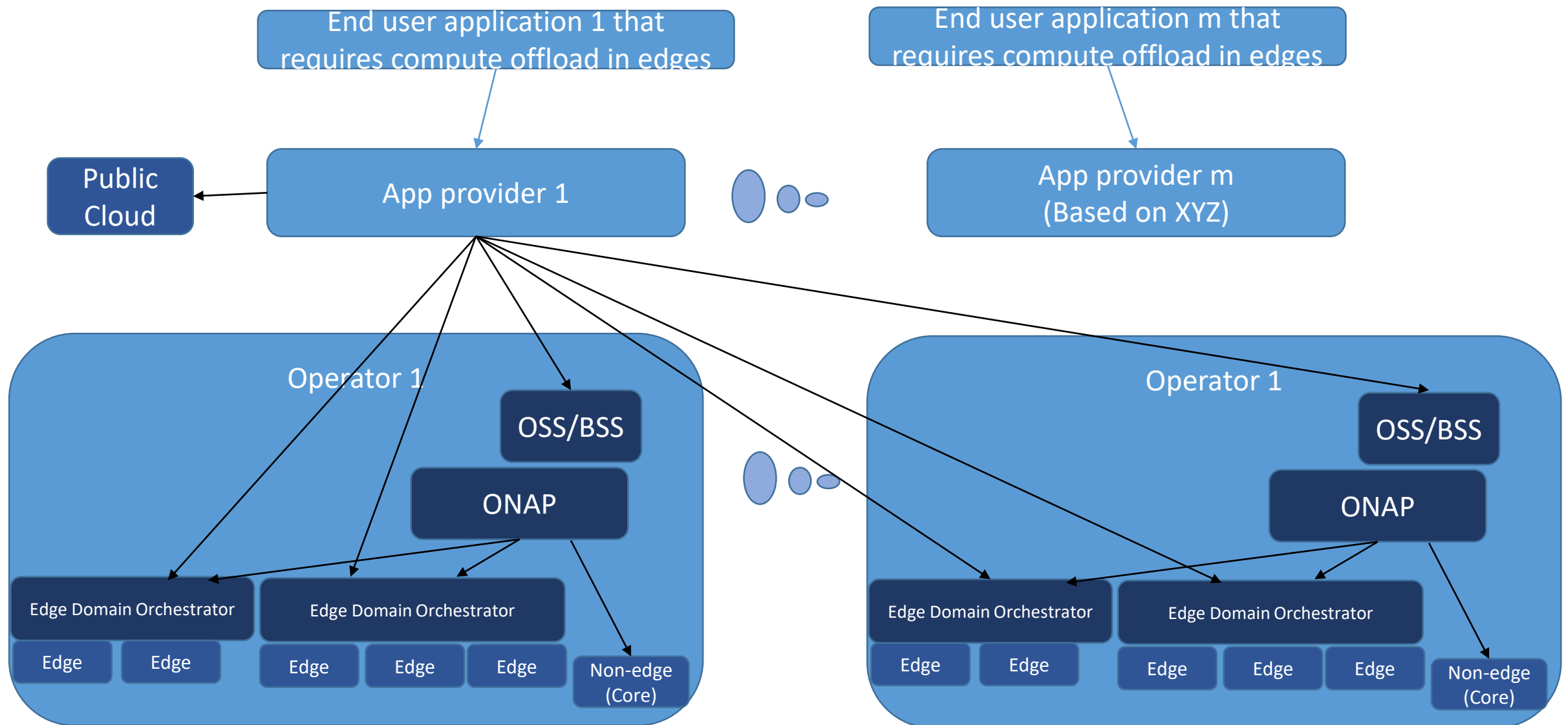

Comparison between ONAP-Managed vs ONAP-unaware Edge App provisioning

ONAP Managed Edge App provisioning:

- App providers only see the ONAP interface to provision applications in any edges managed by ONAP. (ONAP is the entry point for any application provisioning)
- ONAP is used for both telecom VNFs and VNFs & Apps from App providers.
- For scaling with large number of edges, ONAP-Edge (to be developed) will take care of virtualization life cycle management. ONAP-Edge can be instantiated across regional sites.

Pros:

- One interface point per operator to application providers.
- ONAP as an orchestrator for edge apps -> More use cases for ONAP.

Cons:

- ONAP scope change as it deployed third party VNFs/Apps.

ONAP-unaware App provisioning:

- New project – Edge domain Orchestrator. (May be Akraino project or may be MobileEdgeX project or something else)
- App providers communicate with the Edge Domain Orchestrators. ONAP is also considered as one of the consumers of Edge Domain Orchestrators.
- ONAP is only used to on-board & instantiate only telecom VNFs.
- For scaling with large number of edges, Edge Domain Orchestrators will have its own scaling methods.

Pros:

- ONAP scope is unchanged.
- ONAP can be made consumer of Edge Domain orchestrator slowly in future.

Cons:

- Some Edge Domain Orchestrator functionality overlaps with ONAP functionality such as placement decisions, VNF/service onboarding etc...

Edge App Provisioning – ONAP Enhancements (for Choice1)

Edge App provisioning

- ONAP External API (Study and find the gaps)
 - Registration of Application providers (AFs)
 - Dynamic onboarding of NSDs (Services with DynApps/VNFs)
 - Authenticate/authorization of Application providers (Token/Cert based), Mutual TLS
 - Providing information about NEF Manager reachability information (for AF to look for events), DynAPP reachability information to help in creating traffic rules
 - Auto-scaling notifications.
- Traffic rule (steering) creation
 - In UPF via NEF/SMF (ONAP to talk to NEF management systems?).
 - Inter-VNF SFC enhancements in ONAP (DynApp might consists of multiple workloads and may need SFC).
- PNF on boarding (If UPF is PNF) – Existing feature
- ONAP to provide a way to select the best region to place dynamic apps (using UE coordinates, cost and other parameters) – Already existing, more enhancements?
- ONAP to act as Service registry? Or leave it to AF vendors (Leave it to AF vendors to have service registry as workload)
- AF interaction related enhancements in ONAP Network Slicing Controller
- MEC Edge Platform Manager as EMS by Application Providers – ONAP to provide right information to EMS (when Apps come up, App instances go down, etc..) - Should ONAP provide its own MEC platform Manager?



ONAP

OPEN NETWORK AUTOMATION PLATFORM

BACKUP

What changes required in ONAP

Edge Requirement	ONAP Changes (To be filled)
Scalability	
Security	
Regulations	
Performance & Constrained environment	
Edge App provisioning (MEC or others)	
Zero Touch provisioning (Install/Update)	
Network Slicing	
Container & VM VNF deployments	
Analytics	

Edge Deployment Architecture – Various Edge Groups

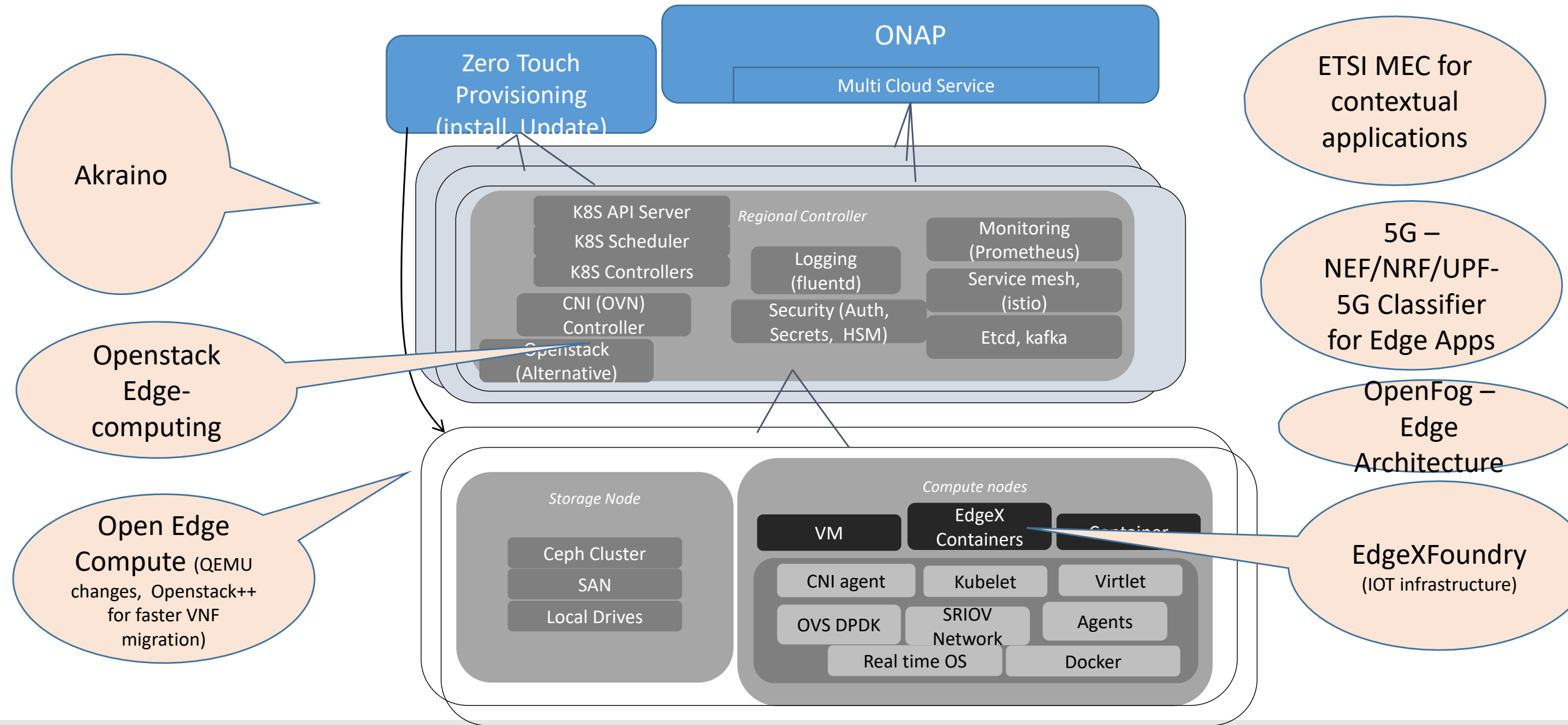



ONAP

OPEN NETWORK AUTOMATION PLATFORM