

# 3GPP management and orchestration of 5G networks and network slicing

Thomas Tovinger, 3GPP SA5 chair

# Contents



- Brief 3GPP introduction
- The role of 3GPP SA5
- 5G Management and orchestration framework
- Key 5G management specification contents
- Network Slicing
- SA5 work plan
- Conclusions

# 3GPP standards eco-system



Participation in 3GPP is made possible by companies and organizations becoming members of one of the 3GPP **Organizational Partners**, the seven Standards Developing Organizations (SDOs) - from China, Europe, India, Japan, Korea and the United States.

Specific inputs, in the form of market requirements may also come in to the Project via any of the twenty **Market Representation Partners** in 3GPP. These organizations have all signed up to the 3GPP Project scope and objectives.

There is also a lot of external cooperation with other standards bodies and a broad variety of other groups, by way of formal Liaisons.

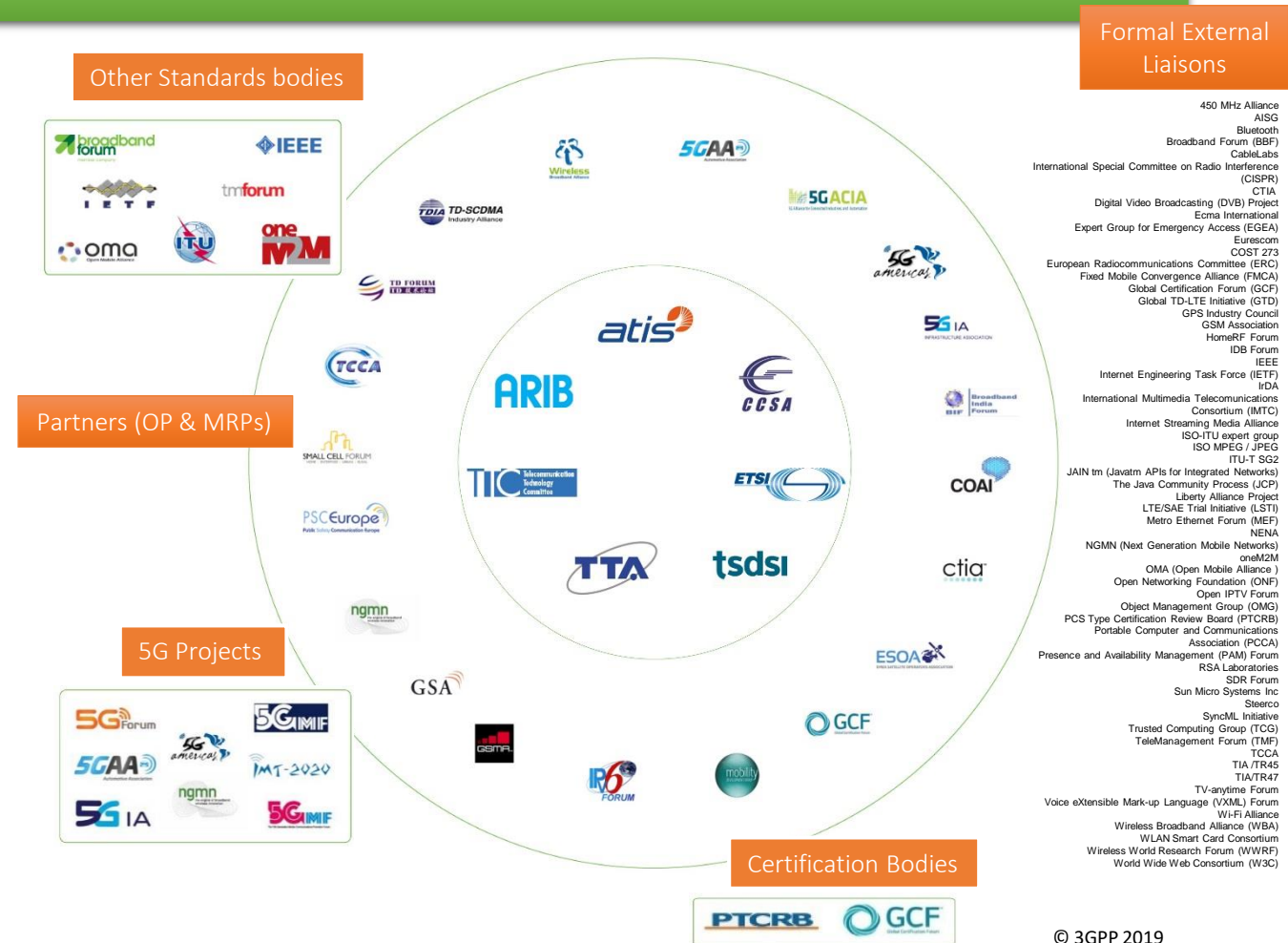

# The role of 3GPP



- 3GPP is part of the invention, proof of concept, **standardization**, trials, commercialization ...cycle
- Its role is to specify and maintain a complete system description for mobile telecommunications
- The system description is characterized by a number of standardized interfaces, not a description of standardized deployment
- This standardization approach enables an interoperable, multi-vendor approach to deployment and generates mass market economies of scale, without stifling innovation

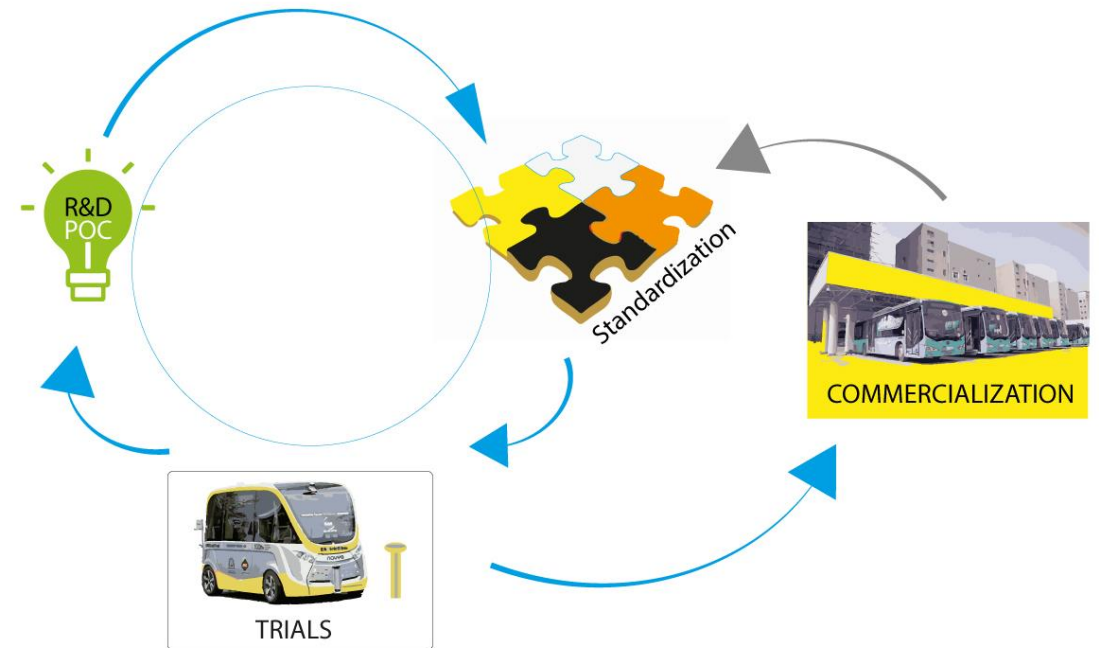

# Where are we now on 5G?



- 3GPP continues to expand the LTE platform to improve its efficiency to meet the mobile broadband demand
- 3GPP is on schedule with the standardization of 5G, addressing the expanded connectivity needs of the future
- Phases for the normative 5G work
  - Phase 1 (Rel-15): Addresses the more urgent subset for commercial deployments
  - Phase 2 (Rel-16): Completes the IMT 2020 submission, addresses all identified use cases & requirements



# 3GPP organization



## Project Coordination Group (PCG)

<b>TSG RAN</b> Radio Access Network
RAN WG1 Radio Layer 1 spec
RAN WG2 Radio Layer 2 spec Radio Layer 3 RR spec
RAN WG3 Iub spec, Iur spec, Iu spec UTRAN O&M requirements (Radio CN Interfaces)
RAN WG4 Radio Performance Protocol aspects
RAN WG5 Mobile Terminal Conformance Testing
RAN WG6 GSM EDGE Radio Access Network

<b>TSG CT</b> Core Network & Terminals
CT WG1 MM/CC/SM (Iu) (end-to-end aspects)
CT WG3 Interworking with external networks
CT WG4 MAP/GTP/BCH/SS (protocols within the CN)
CT WG6 Smart Card Application Aspects

<b>TSG SA</b> Service & Systems Aspects
SA WG1 Services
SA WG2 Architecture
SA WG3 Security
SA WG4 Codec & Media
SA WG5 Telecom Management
SA WG6 Mission-Critical Applications

# Bringing the work in to the groups

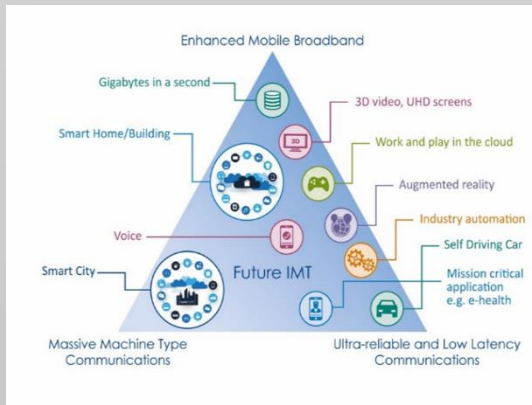

## Use Cases

- Higher Data Rates
- Higher User Mobility
- Highly variable data rates
- Diverse Deployments
- Improved Coverage

## Overall Goals

- **Enable new business**
- **Greater Efficiency (lower cost per bit for capital investment, operations & energy)**
- **Flexibility (not one-size fits all system)**

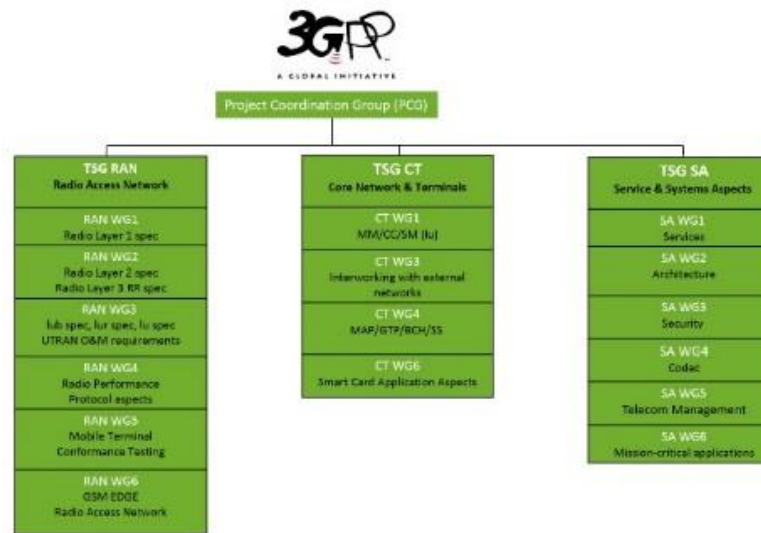
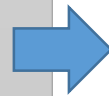

## 3GPP Specifications and Reports:

Requirements	21 series
Service aspects ("stage 1")	22 series
Technical realization ("stage 2")	23 series
Signalling protocols ("stage 3") - user equipment to network	24 series
Radio aspects	25 series
CODECs	26 series
Data	27 series
Signalling protocols ("stage 3") -(RSS-CN) and OAM&P and Charging (overflow from 32.- range)	28 series
Signalling protocols ("stage 3") - intra-fixed-network	29 series
Programme management	30 series
Subscriber Identity Module (SIM / USIM), IC Cards. Test specs.	31 series
OAM&P and Charging	32 series
Security aspects	33 series
UE and (U)SIM test specifications	34 series
Security algorithms	35 series
LTE (Evolved UTRA), LTE-Advanced, LTE-Advanced Pro radio technology	36 series
Multiple radio access technology aspects	37 series
Radio technology beyond LTE	38 series

# The role of 3GPP SA5



- The sole group responsible for management, orchestration and charging standards for 3GPP networks
- Coordinates with all 3GPP working groups
- Communicates with other SDOs and industry fora

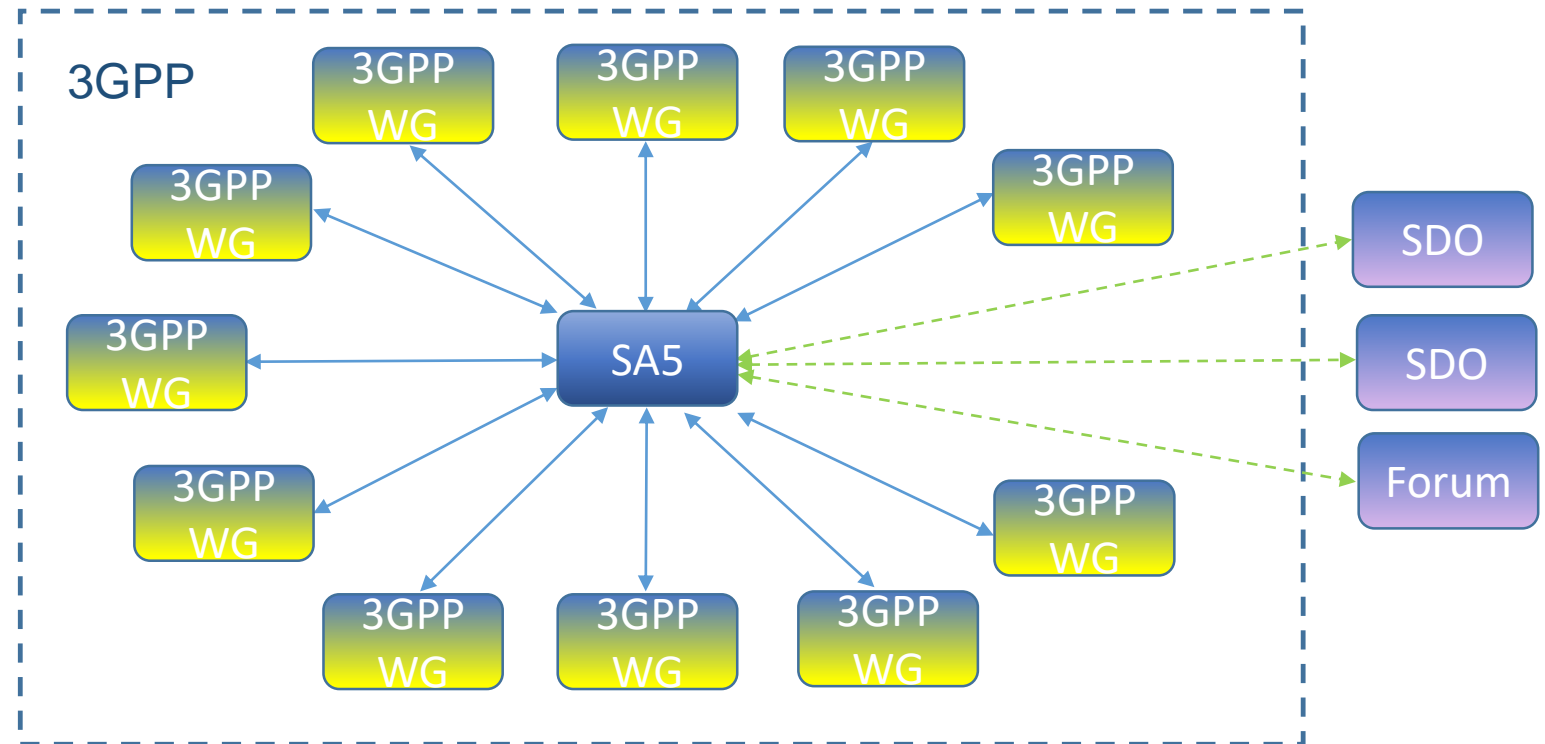



# Management and orchestration framework



- Service oriented
- Based on management service components (MnS): type A, B, C



# Management and orchestration framework



Examples of MnSs and component type A, B and C

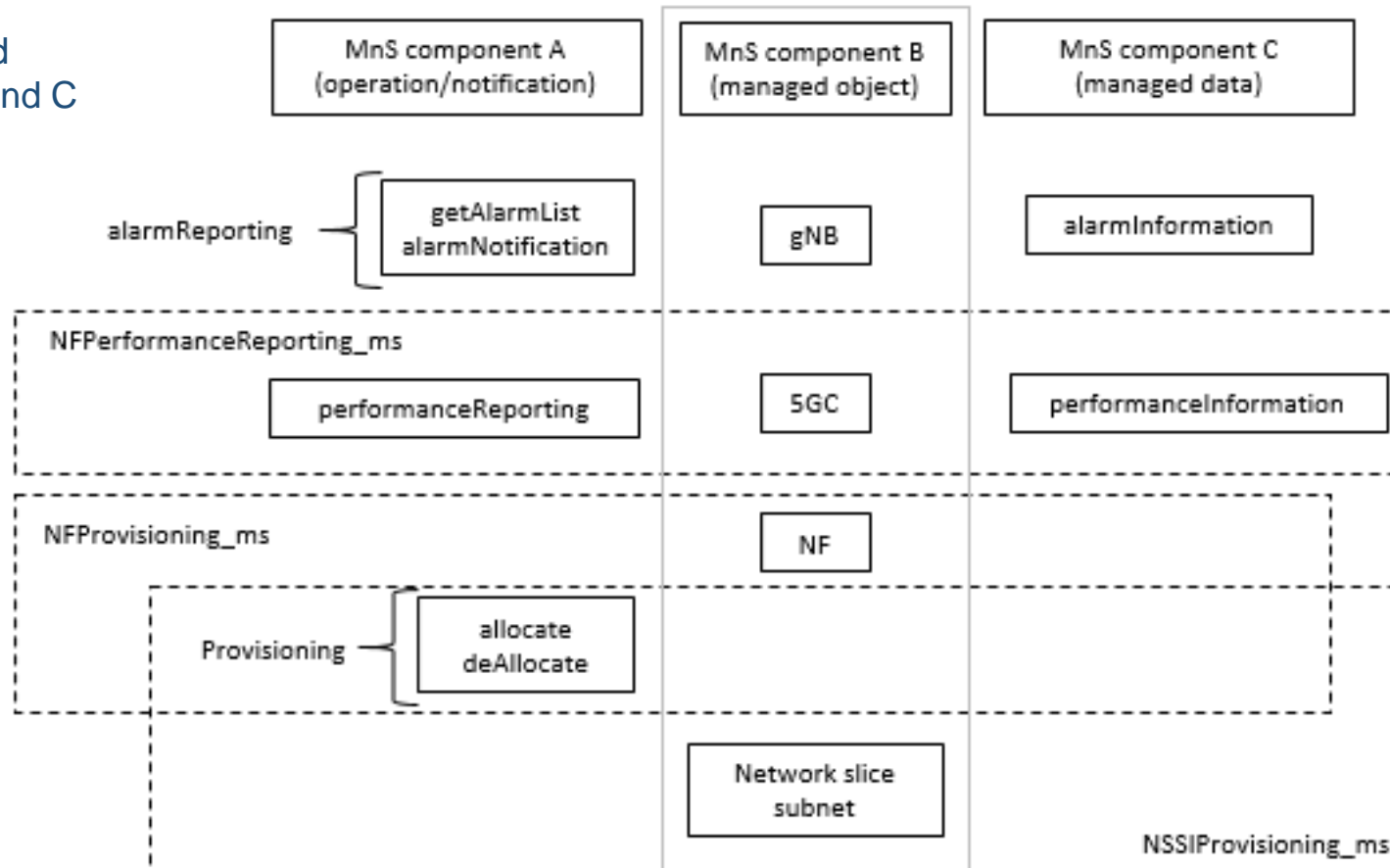

# Management and orchestration framework

- Management Function (MnF): Plays the role of either Management Service (MnS) producer or MnS consumer, or both.

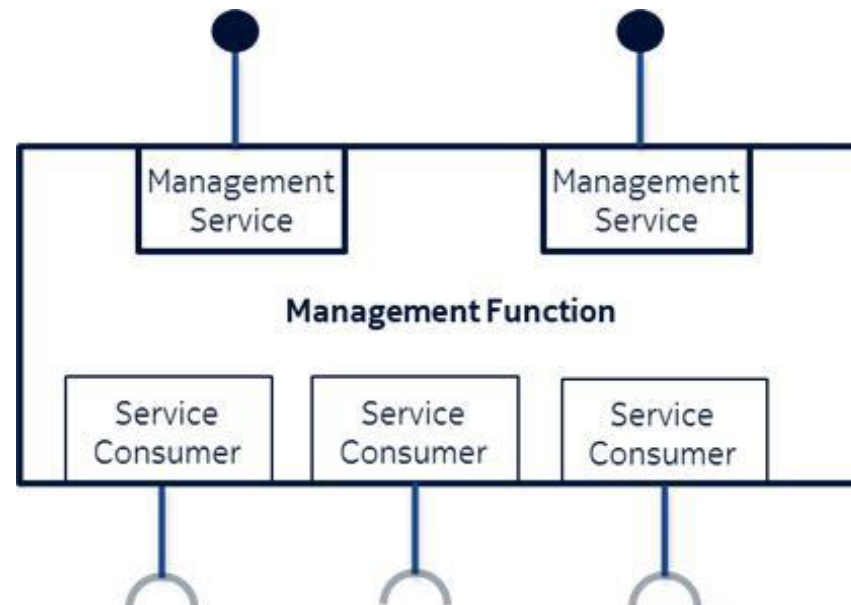

# Management and orchestration framework

Example of deployment scenario for management of a mobile network including network slicing

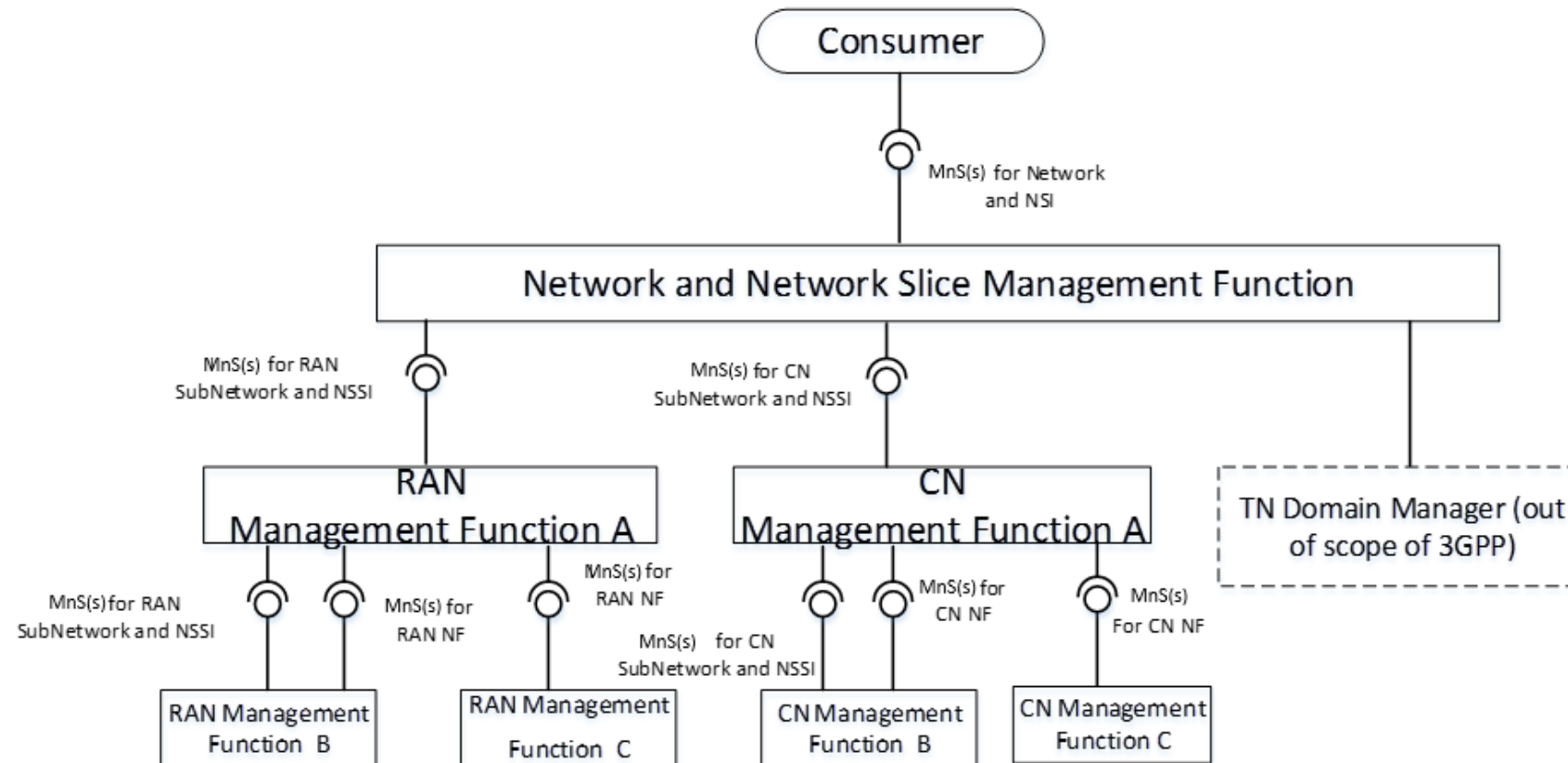

# Management and orchestration framework

Example deployment scenario for NSSI management with interface to NFV-MANO

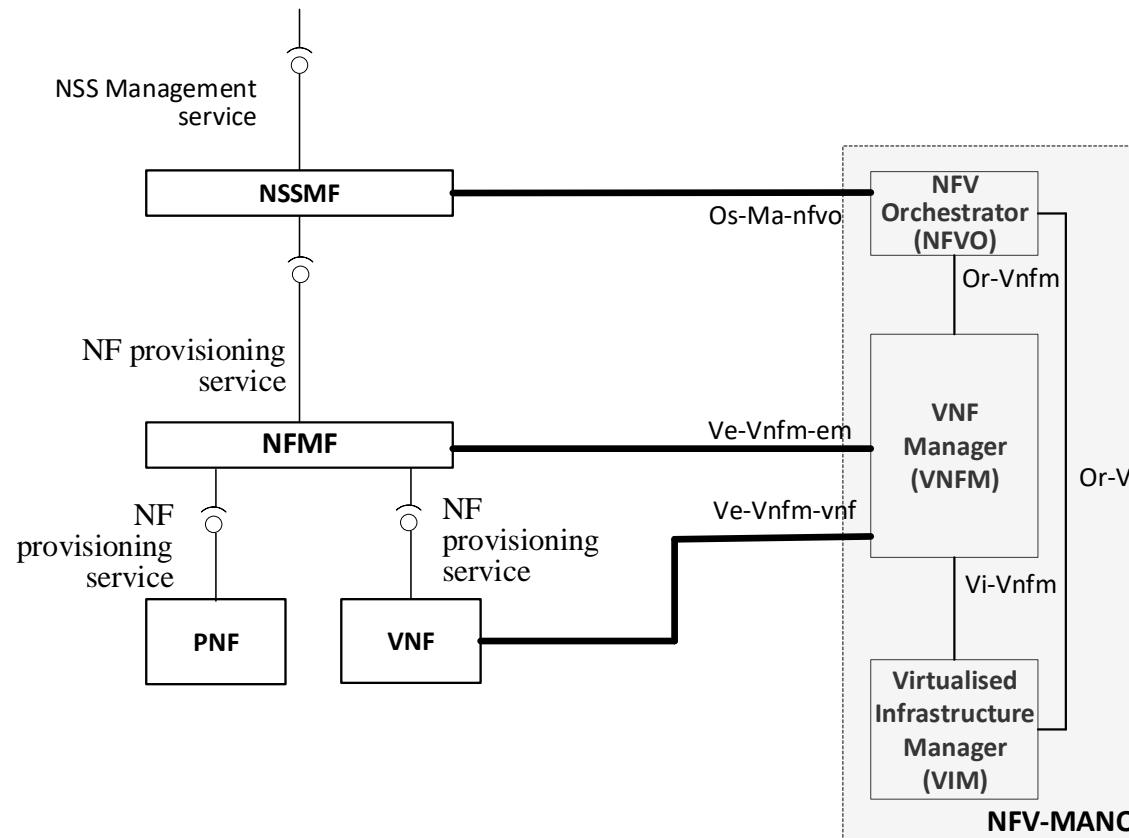

# Key 5G management specifications / contents



- Management concept, use cases, requirements, framework and architecture: 3GPP TS 28.530, 28.533
- Provisioning: TS 28.531
- Generic management services (for Provisioning, FM, PM): 28.532
- Network Resource Model (NRM): TS 28.540, 28.541
- Performance measurements/KPIs & assurance: TS 28.550/552/554

- Requirements: E.g. Requirements for network slice provisioning service
- Use cases: E.g. Network slice instance creation
- Management services for provisioning: E.g.
  - Management services for network slice provisioning:
    - createMOI operation
    - allocateNsi operation
    - notifyProvisioning notification
    - etc.

# Network Resource Model (NRM)

## Scope and structure of the NRM

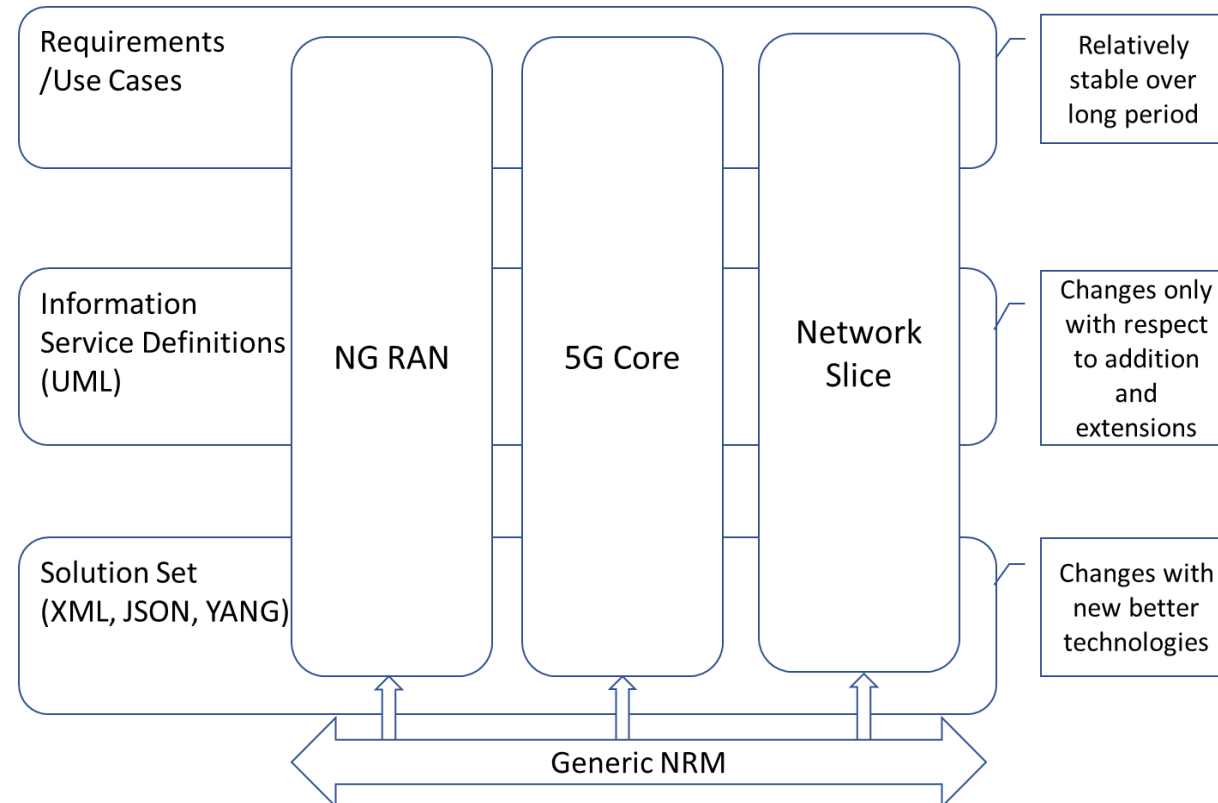



# Network Resource Model (NRM)

## Generic NRM

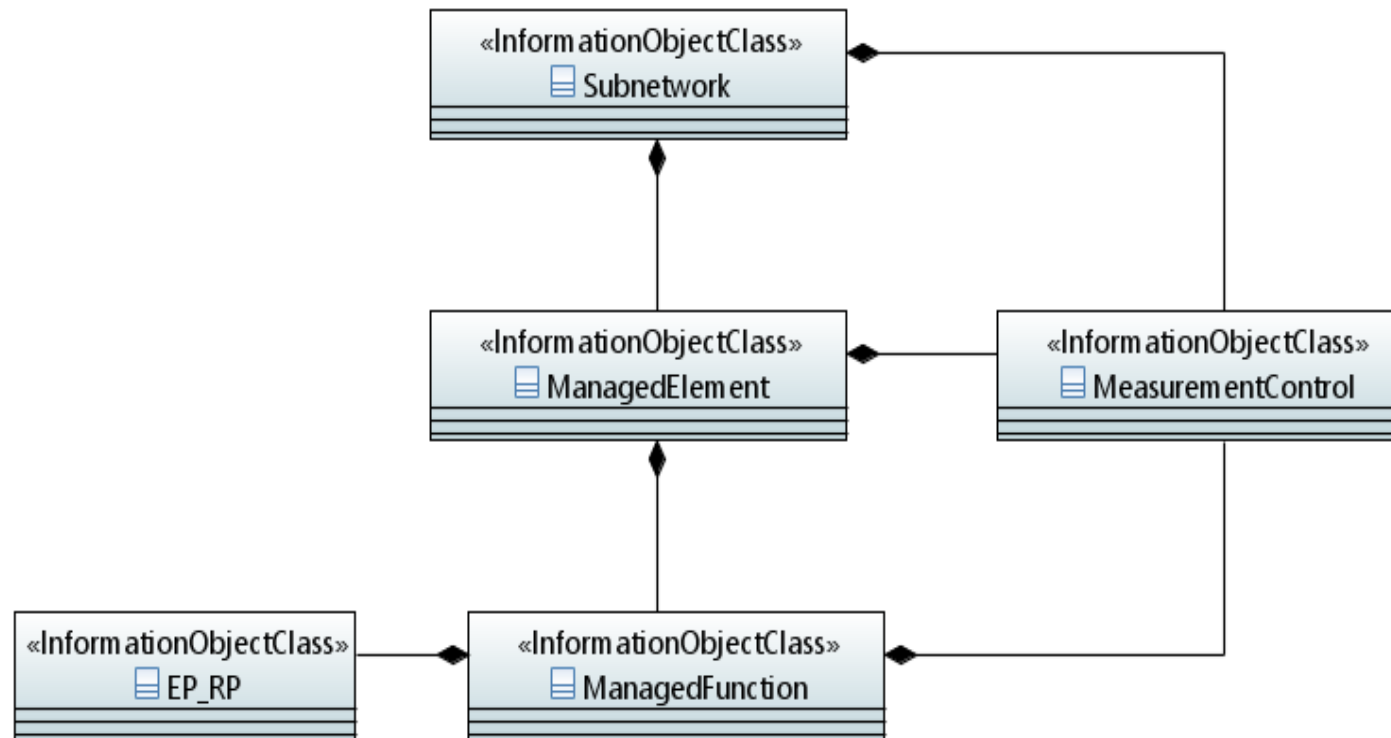

# Network Resource Model (NRM)

NG-RAN – High-level and cell relation view

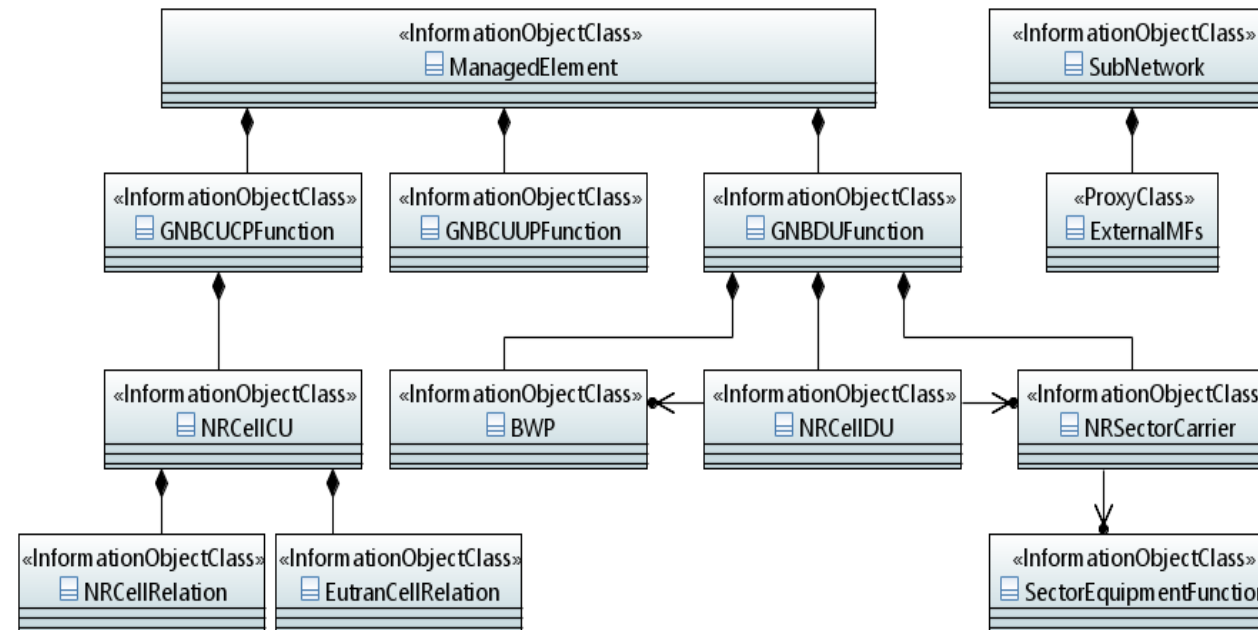

# Network Resource Model (NRM)

## NG-RAN – Combined gNB cell state diagram

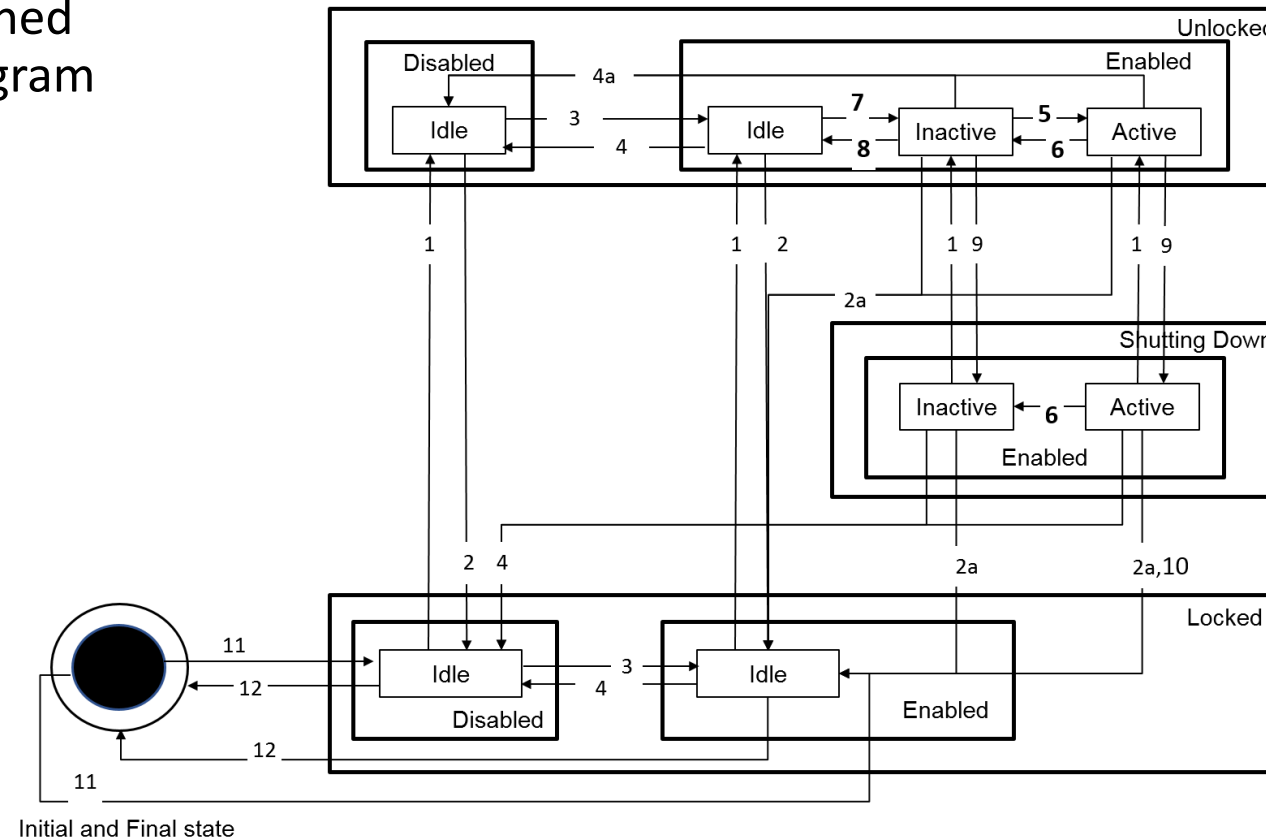

# Network Resource Model (NRM)

5GC – High-level view

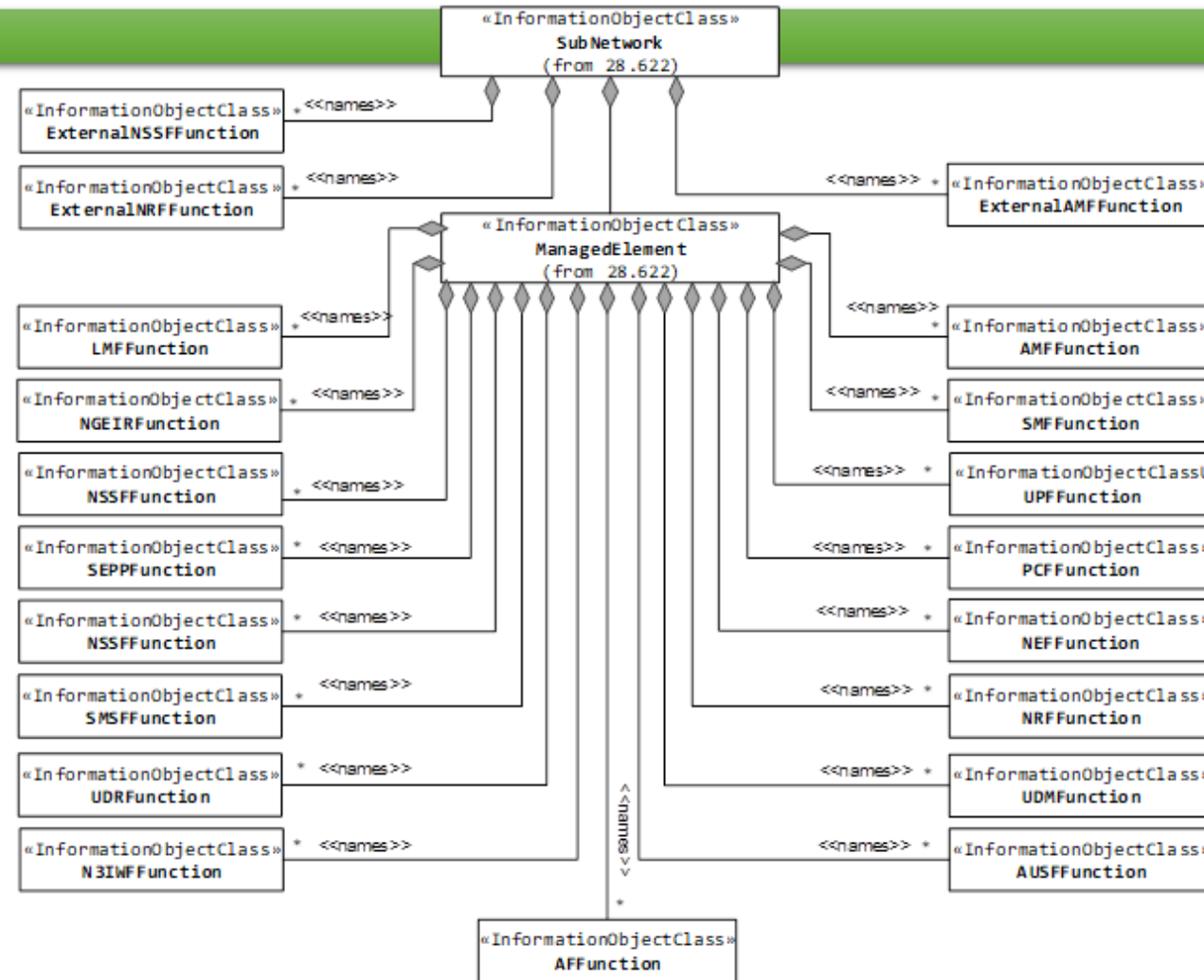

# Network Resource Model (NRM)

## 5GC - Transport view of SMF NRM

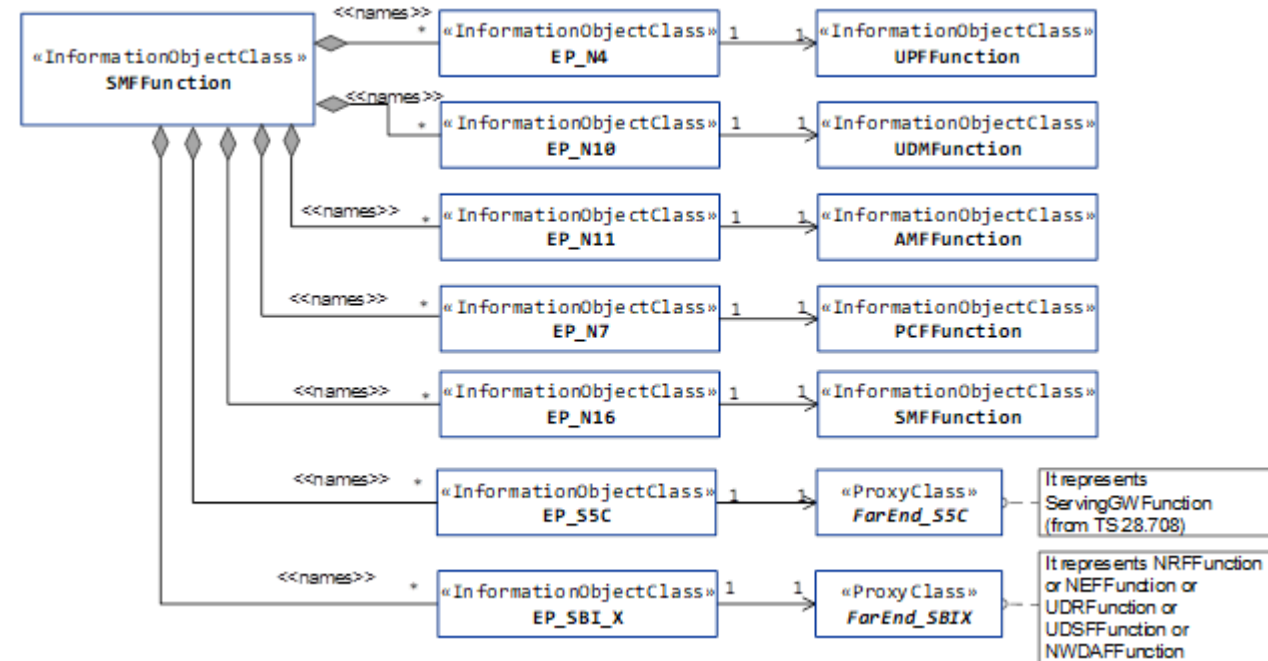

# Network Slicing

- Definition of concepts & terms for network slicing in addition to the basic terms defined by SA2 in TS 23.501
- Provisioning operations, notifications etc. (seen above)
- Measurements/KPIs
- NRM definitions:

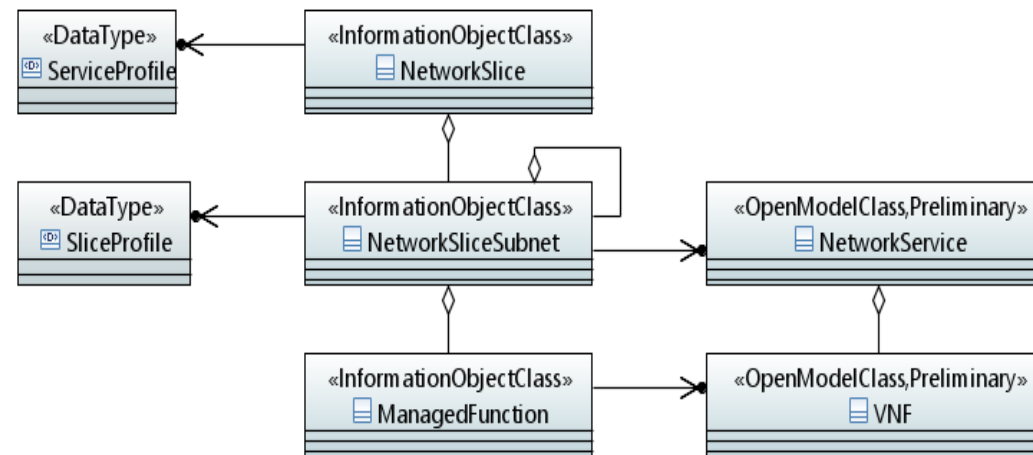

# 5G Performance measurements/KPIs & assurance



- Performance measurements and KPIs are defined for network functions including NG-RAN and 5GC, and for network slice instances in terms of E2E QoS.
- Measurement job control service: To allow the consumer to create, stop and list the measurement jobs.
- The consumer can choose to get the measurement results by file or by streaming.

# SA5 work plan



# Summary of ongoing work items (1/3)



WI Title	Target date
Volume Based Charging Aspects for VoLTE	SA#84 (06/2019)
Nchf Online and Offline Charging Services	SA#85 (09/2019)
Charging Enhancement of 5GC interworking with EPC	SA#85 (09/2019)
Network Exposure Charging in 5G System Architecture	SA#86 (12/2019)
Charging AMF in 5G System Architecture Phase 1	SA#85 (09/2019)
Study on Charging Aspects of Network Slicing	SA#85 (09/2019)

# Summary of ongoing work items (2/3)



WI Title	Target date
Management of QoE measurement collection	SA#85 (09/2019)
Energy efficiency of 5G	SA#86 (12/2019)
Network policy management for mobile networks based on NFV scenarios	SA#85 (09/2019)
Methodology for 5G management specifications	SA#84 (06/2019)
Intent driven management services for mobile network	SA#86 (12/2019)
Enhancement of performance assurance for 5G networks including network slicing	SA#86 (12/2019)
Discovery of management services in 5G	SA#85 (09/2019)
NRM enhancements	SA#85 (09/2019)
Trace Management in the context of Services Based Management Architecture	SA#84 (06/2019)
Integration of ONAP and 3GPP 5G management framework	SA#87 (03/2020)

# Summary of ongoing work items (3/3)



WI Title	Target date
Study on management aspects of edge computing	SA#85 (09/2019)
Study on protocol enhancement for real time communication	SA#86 (12/2019)
Study on tenancy concept in 5G network and network slicing management	SA#85 (09/2019)
Study on management aspects of communication services	SA#85 (09/2019)
Study on Self-Organizing Networks (SON) for 5G	SA#86 (12/2019)
Study on non-file-based trace reporting	SA#84 (06/2019)
Study on non-public networks management	SA#86 (12/2019)
Study on management and orchestration aspects with integrated satellite components in a 5G network	SA#86 (12/2019)

# Conclusions



- 3GPP is an industry driven standardization activity with truly global reach
- Standardization of interfaces enables an interoperable, multi-vendor approach to deployment and generates mass market economies of scale
- NR remains high focus for RAN groups
- IMT-2020 '5G' process progressing – 3GPP leading the way
- Release 16 focus continues to expand towards new use cases and new sectors
- 5G will be a multi-Release technology (beyond Release 16)
- SA5 remains the focal point for management and orchestration

# Acknowledgements

- To Ms. Jing Ping (Nokia) for designing the NRM diagrams used in this presentation, originally made for a special “Operations” issue of the Journal of ICT standardization (<https://www.riverpublishers.com/journal.php?j=JICTS>)
- To Ms. Zou Lan (SA5 rapporteur, Huawei) and Dr. Jean-Michel Cornily (SA5 VC and rapporteur, Orange) for constructive suggestions and comments on this presentation.

# Thank you!



For more Information:



[info@3gpp.org](mailto:info@3gpp.org)

[thomas.tovinger@ericsson.com](mailto:thomas.tovinger@ericsson.com)



[www.3gpp.org](http://www.3gpp.org)

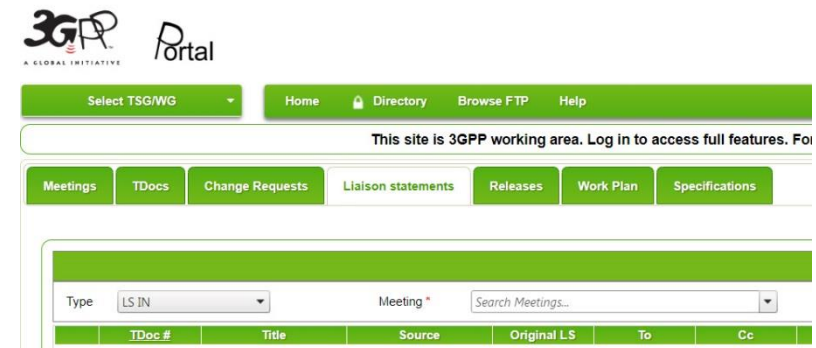

[portal.3gpp.org](http://portal.3gpp.org)