



ONAP

OPEN NETWORK AUTOMATION PLATFORM

Open Wireless Lab

2019-06-12

WINLAB at Rutgers University – ONAP Community Lab



WINLAB Tech Center Facility

WINLAB founded in 1989 as a collaborative industry-university research center with specialized focus on wireless networking



~25 faculty/staff, most from the ECE and CS departments at Rutgers

~40-50 grad students (80% PhD, 20% MS)

- Center's research portfolio spans information theory, radio technology, wireless systems, mobile networks and computing
- Extensive experimental research infrastructure including ORBIT & GENI testbeds, SDR, SDN, ...



Low Power IoT Device



Massive MIMO



SDR



ORBIT Radio Grid Testbed



GENI Rack



SDN



CloudLab Rack

WINLAB Designated by NSF as NJ/NYC PAWR Testbed

COSMOS

Cloud Enhanced Open Software Defined Mobile Wireless Testbed for City-Scale Deployment

The COSMOS project is aimed at design, development, and deployment of a city-scale advanced wireless testbed in order to support real-world experimentation on next-generation wireless technologies and applications.

The COSMOS architecture has a particular focus on ultra-high bandwidth and low latency wireless communication tightly coupled with edge cloud computing. The COSMOS testbed will be deployed in upper Manhattan and will consist of 40-50 advanced software-defined radio nodes along with fiber-optic front-haul and back-haul networks and edge and core cloud computing infrastructure. Researchers will be able to run experiments remotely on the COSMOS testbed by logging into a web-based portal which will provide various facilities for experiment execution, measurements, and data collection.

Open Wireless Lab (OWL) at WINLAB/COSMOS

- Environment
 - Entry point at console located at console.sb10.orbit-lab.org
 - 10 Ubuntu servers, all managed by OpenStack
 - Control Node: Node 1-1
 - Compute Nodes: Node 2-1 through 2-9
- Access Methods
 - One can gain access by requesting an account at WINLAB
 - <https://wiki.onap.org/pages/viewpage.action?pageId=45298557>

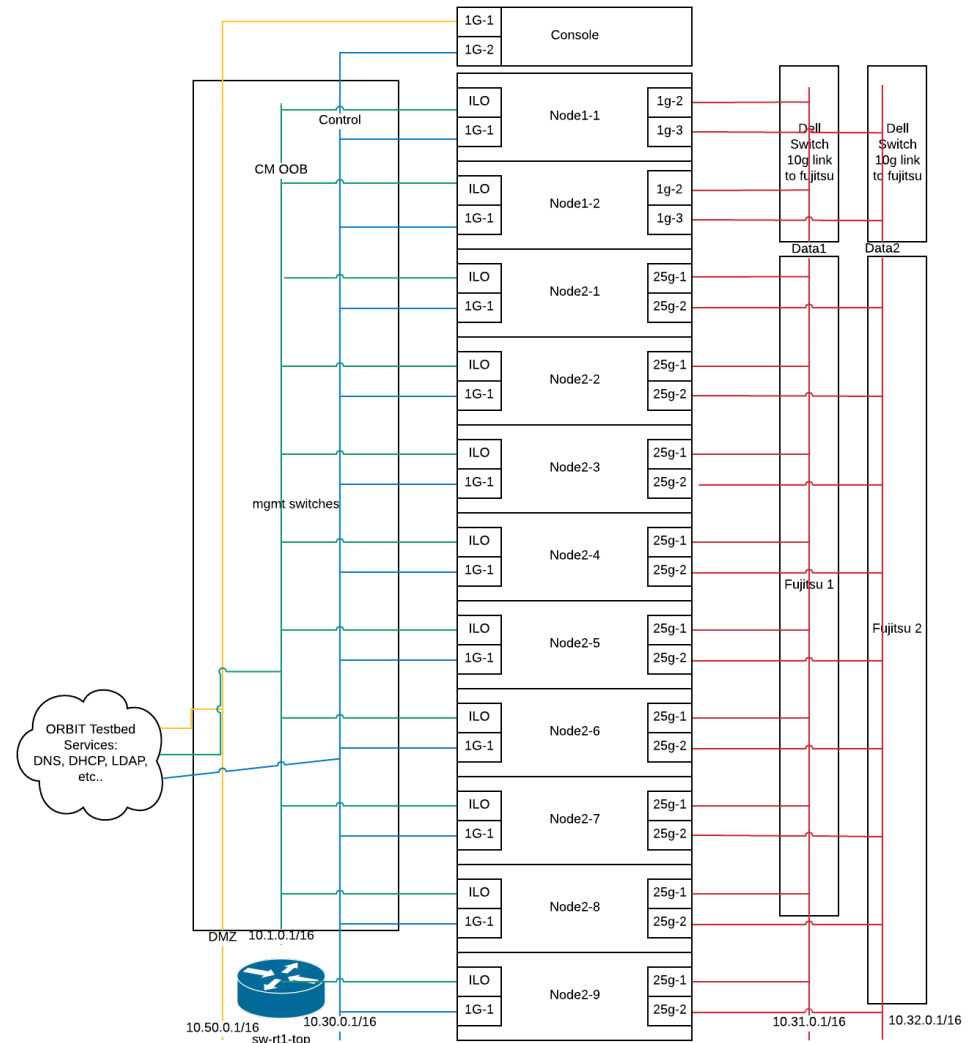

Open Wireless Lab (OWL)

- ONAP Dublin Installation
 - Three Rancher servers
 - Twelve Kubernetes nodes
 - One NFS server
 - Two VMs hosting 10,000 NETCONF simulators (in progress)

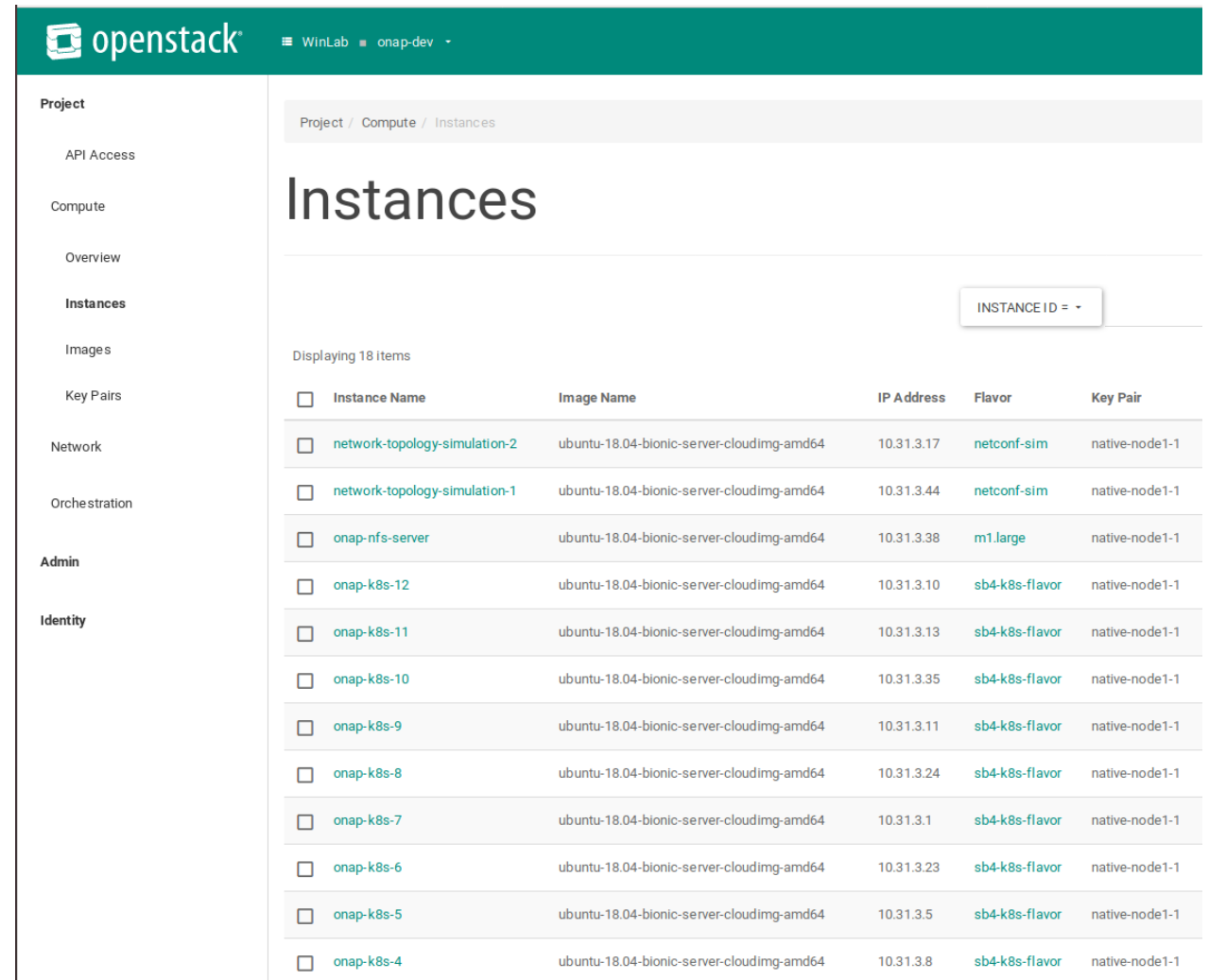

The screenshot shows the OpenStack dashboard interface. The top navigation bar includes the OpenStack logo and the project name 'WinLab' with a sub-project 'onap-dev'. The left sidebar contains a navigation menu with categories: Project, Compute, Overview, Instances, Images, Key Pairs, Network, Orchestration, Admin, and Identity. The main content area is titled 'Instances' and shows a list of 18 instances. The table columns are Instance Name, Image Name, IP Address, Flavor, and Key Pair. The instances listed include 'network-topology-simulation-2', 'network-topology-simulation-1', 'onap-nfs-server', and a series of 'onap-k8s' nodes from 4 to 12.

Instance Name	Image Name	IP Address	Flavor	Key Pair
network-topology-simulation-2	ubuntu-18.04-bionic-server-cloudimg-amd64	10.31.3.17	netconf-sim	native-node1-1
network-topology-simulation-1	ubuntu-18.04-bionic-server-cloudimg-amd64	10.31.3.44	netconf-sim	native-node1-1
onap-nfs-server	ubuntu-18.04-bionic-server-cloudimg-amd64	10.31.3.38	m1.large	native-node1-1
onap-k8s-12	ubuntu-18.04-bionic-server-cloudimg-amd64	10.31.3.10	sb4-k8s-flavor	native-node1-1
onap-k8s-11	ubuntu-18.04-bionic-server-cloudimg-amd64	10.31.3.13	sb4-k8s-flavor	native-node1-1
onap-k8s-10	ubuntu-18.04-bionic-server-cloudimg-amd64	10.31.3.35	sb4-k8s-flavor	native-node1-1
onap-k8s-9	ubuntu-18.04-bionic-server-cloudimg-amd64	10.31.3.11	sb4-k8s-flavor	native-node1-1
onap-k8s-8	ubuntu-18.04-bionic-server-cloudimg-amd64	10.31.3.24	sb4-k8s-flavor	native-node1-1
onap-k8s-7	ubuntu-18.04-bionic-server-cloudimg-amd64	10.31.3.1	sb4-k8s-flavor	native-node1-1
onap-k8s-6	ubuntu-18.04-bionic-server-cloudimg-amd64	10.31.3.23	sb4-k8s-flavor	native-node1-1
onap-k8s-5	ubuntu-18.04-bionic-server-cloudimg-amd64	10.31.3.5	sb4-k8s-flavor	native-node1-1
onap-k8s-4	ubuntu-18.04-bionic-server-cloudimg-amd64	10.31.3.8	sb4-k8s-flavor	native-node1-1

Open Wireless Lab (OWL)

- Network Capacities
 - Two Fujitsu switches
 - 25g access
 - 100g interconnect
- Storage Capacities
 - Node 1-1: 3900 GB
 - Node 2-1, Node 2-2: 14 TB/48 cores/700 GB RAM
 - Node 2-3 through Node 2-9: 480 GB/48 cores/186 GB RAM
 - **Note:** Node 2-3 through Node 2-9 will be receiving a 4 TB (two 2 TB SSDs each) storage upgrade by mid-July

High-Availability ONAP Installation

- OpenStack Pike for cloud infrastructure
- Open source software Rancher, Helm, Kubernetes and docker are deployed in the VMs to create high-availability Rancher and Kubernetes Cluster environment.
- The deployment of the ONAP components is done using ONAP helm charts from the “oom” git repository
- https://onap.readthedocs.io/en/latest/submodules/oom.git/docs/oom_cloud_setup_guide.html
- Currently deployed ONAP components at OWL:
 - AAI
 - Log
 - OOF
 - Policy
 - Portal
 - Robot
 - SDNC
 - SNIRO Emulator
 - SO

ONAP Logs

The screenshot shows the Kibana interface with the following components:

- Header:** Kibana logo and search bar containing "28,971 hits" and a search query "Search... (e.g. status:200 AND extension:PHP)".
- Left Sidebar:** Navigation menu with options: Discover, Visualize, Dashboard, Timelion, Dev Tools, and Management.
- Selected Fields:** A list of fields including @timestamp, @version, className, errorCode, errorDesc, requestId, serviceName, targetEntity, thread, timestamp, _id, _index, _score, _type, beat.hostname, beat.name, beat.version, and componentLogFile.
- Visualizations:** A bar chart titled "logstash-*" showing the count of logs per 30-second interval from 13:12:00 to 13:26:00. The y-axis is labeled "Count" and ranges from 0 to 1,000. The x-axis is labeled "@timestamp per 30 seconds".
- Log Entries:** A list of log entries with the following details:
 - Entry 1:** June 12th 2019, 13:26:38.290. componentLogFile: ajsc-jetty/localhost_access.log. @timestamp: June 12th 2019, 13:26:38.290. of e: aai-traversal beat.name: aai-traversal beat.version: 5.5.0 host: aai-traversal source: / e: ajsc-jetty message: 10.42.7.35 - AAI [12/Jun/2019:11:26:37 +0000] "GET /aai/util/echo" 200 tags: _grokparsefailure _id: AwTlCJfXBxD9y9XIZ-of _type: logs _index: logstash-2019.06.12
 - Entry 2:** June 12th 2019, 13:26:37.290. componentLogFile: ajsc-jetty/localhost_access.log. @timestamp: June 12th 2019, 13:26:37.290. of beat.name: aai-traversal beat.version: 5.5.0 input_type: log host: aai-traversal source: / e: ajsc-jetty message: 10.42.7.35 - AAI [12/Jun/2019:11:26:35 +0000] "GET /aai/util/echo" 200 tags: _grokparsefailure _id: AwTlCJfXBxD9y9XIZ-oe _type: logs _index: logstash-2019.06.12
 - Entry 3:** June 12th 2019, 13:26:35.490. componentLogFile: external/external.log. @timestamp: June 12th 2019, 13:26:35.490. offset: 98, sources beat.name: aai-resources beat.version: 5.5.0 host: aai-resources source: /var/log/o e: at org.eclipse.jetty.servlet.ServletHandler.doHandle(ServletHandler.java:540) type: log ti gs _index: logstash-2019.06.12 _score: -
 - Entry 4:** June 12th 2019, 13:26:35.490. componentLogFile: external/external.log. @timestamp: June 12th 2019, 13:26:35.490. offset: 98, sources beat.name: aai-resources beat.version: 5.5.0 host: aai-resources source: /var/log/o e: at org.eclipse.jetty.server.handler.ScopedHandler.handle(ScopedHandler.java:146) type: log e: logs _index: logstash-2019.06.12 _score: -

Future Considerations and References

- Goal: Three ONAP Installations
 - Stable
 - Developer
 - Sandbox
 - Short experiments, wiped and refreshed every day
 - Only stable instance is currently installed
- WINLAB: <http://www.winlab.rutgers.edu/>
- ORBIT Lab: <https://www.orbit-lab.org/>
- COSMOS: <https://www.cosmos-lab.org/>

BACKUP

COSMOS: System Architecture

- System design based on three levels of SDR radio node (S,M,L) with M,L connected via fiber to optical WDM transport
- SDN-based backhaul and compute services, with access to ORBIT, GENI...
- COSMOS control center and general purpose cloud at Rutgers via 32 AoA PoP

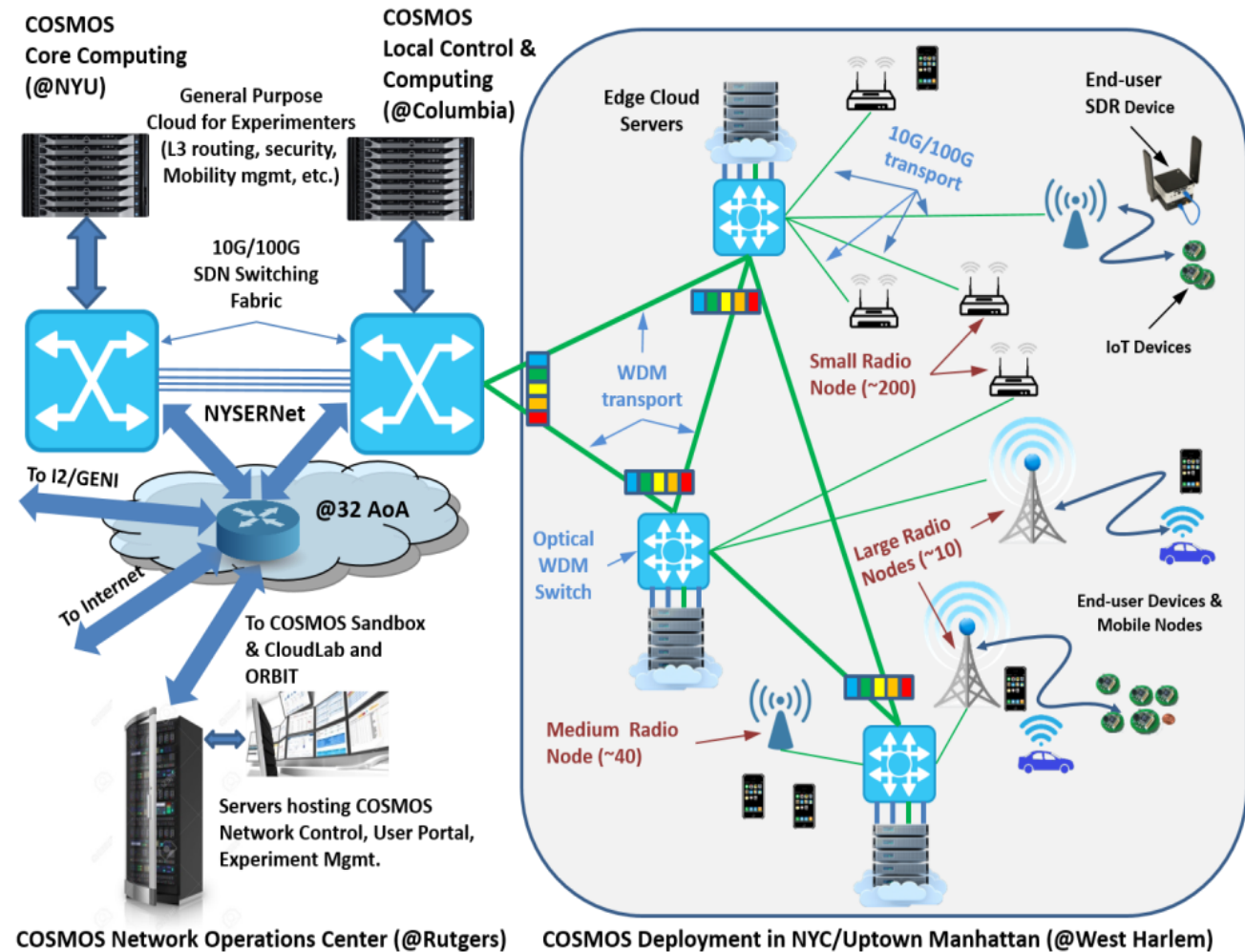

COSMOS: Optical Deployment View

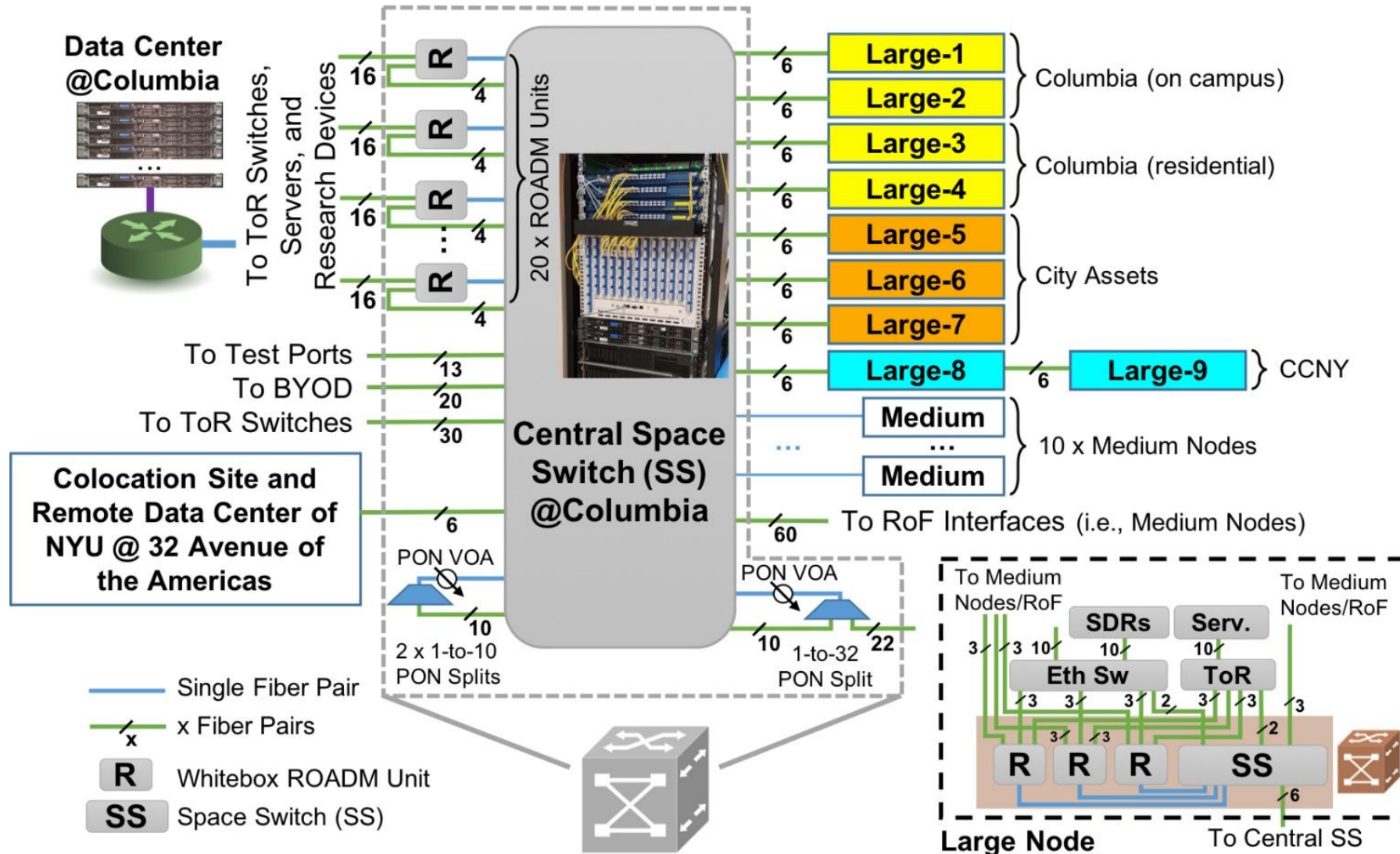

COSMOS: Cloud Architecture

Data Center @Columbia

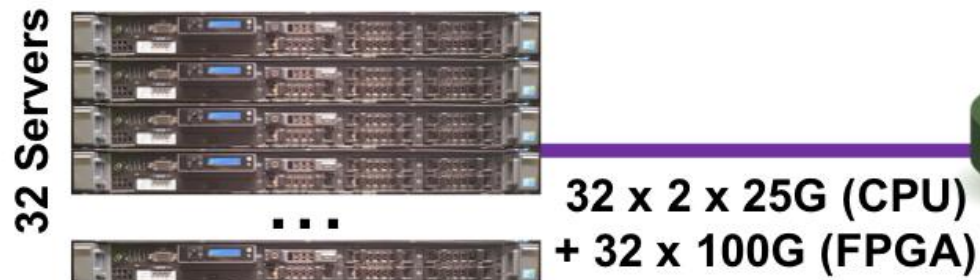
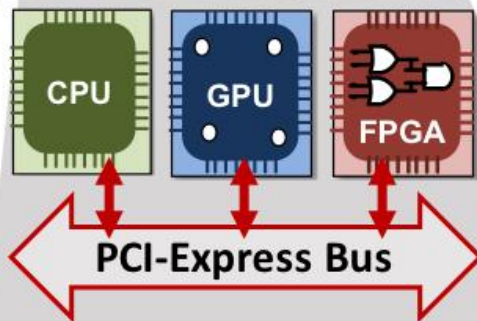
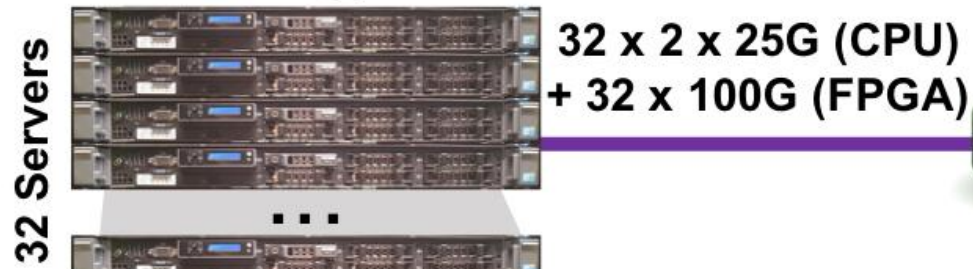

Data Center @NYU

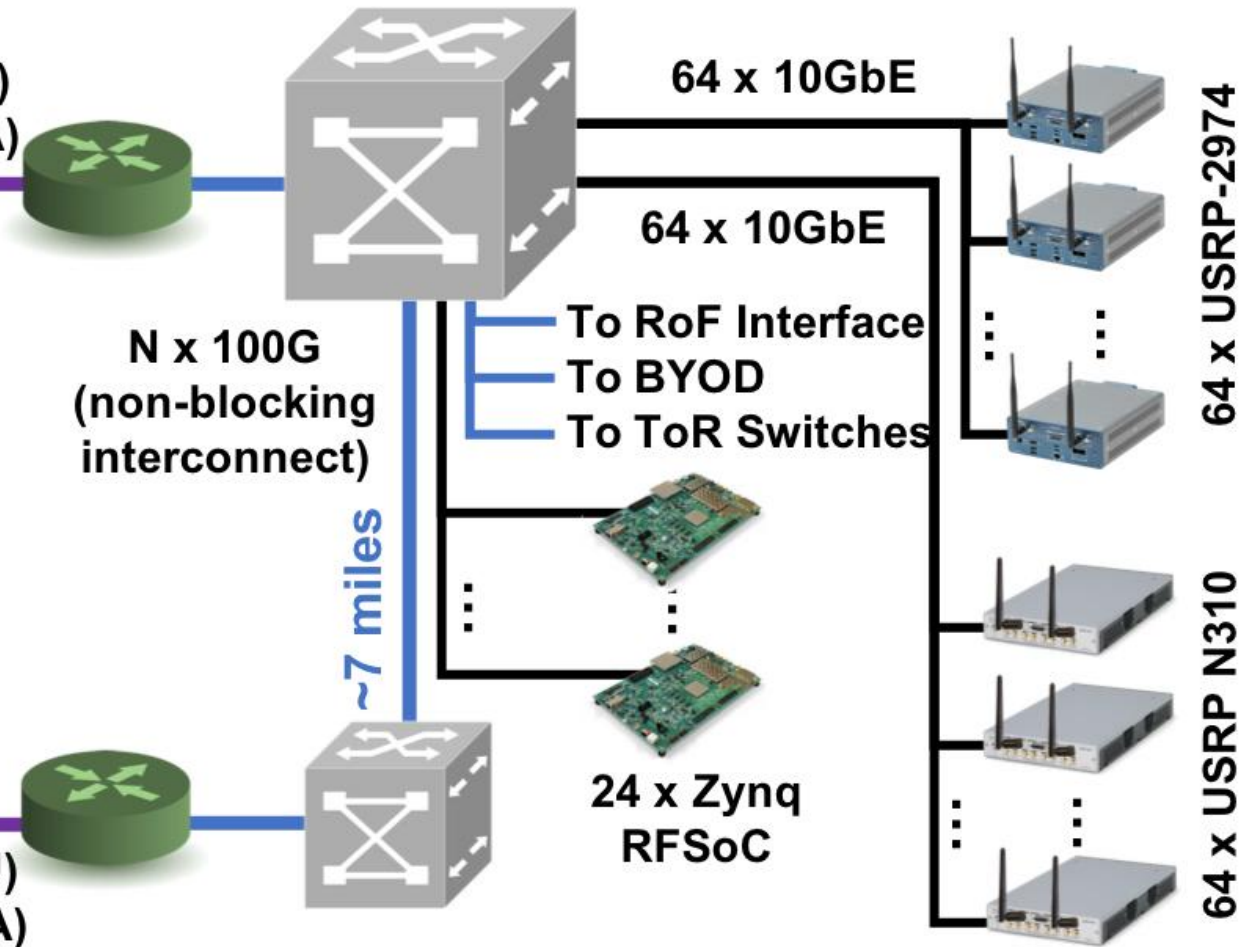

COSMOS: Layer-2 Deployment View

