

# ETSI-Alignment Task Force Update

Antwerp, 26-27 September, 2019

Byung-Woo Jun, Michael Morris, Magnus Buhrgard, Ericsson

Fred Oliveira, Rajesh R, Rishi Tandon, Verizon

Yan Yang, CMCC

Maopeng Zhang, ZTE

Samuli Silvius, Katsia Kazak, Samsung

Alex Vul, Ruoyu Ying, Lianhao Lu, Intel

Thinh Nguyenphu, Nokia

Seshu Kumar, Huawei

Others from ETSI Alignment Task Team

Orchestration Scenarios (a.k.a. ETSI-Alignment) Task Force weekly meeting,

Weekly meeting: Mondays at 12PM UTC, 5AM PT, 8AM ET, 2PM CET, 5:30PM India, 8PM China.

<https://zoom.us/j/722438866>

One tap mobile: +16699006833,,722438866# US (San Jose)

+16465588656,,722438866#

US (New York)

# Agenda

- ONAP ETSI Alignment Requirements
- ETSI MANO and ONAP ETSI Alignment Landscape
- ONAP ETSI-Alignment Overall Architecture
- ONAP ETSI Package Management (Onboarding and Distribution)
- ONAP ETSI Package Security & Validation
- Communication Security between ONAP and SVNFM/NFVO
- ONAP ETSI Catalog Management
- SOL003 Adapter Architecture & Use Cases
- Granting with HPA, Leveraging OOF
- SOL005 Adapter Architecture & Use Cases
- SOL002 Adapter Architecture & Use Cases

# ONAP ETSI Alignment Requirements

- ONAP shall support ETSI standards for packaging, distribution, LCM operations, security and monitoring for managing VNF, PNF and NS.
  - ONAP shall support SOL004 and SOL007 package onboarding and distribution (VNFS SDK, SDC, SO, VFC and others)
  - ONAP shall support ETSI Package security and validation (VNFS SDK, SDC, SVNFM, VFC, External NFVO)
  - ONAP shall support ETSI package catalog in runtime (SO, ONAP-ETSI Catalog Manager)
- External VNFM scenarios :
  - ONAP shall ingest and save (without modification) a SOL004 CSAR package for later consumption by a SOL003 compliant VNFM/NFVO (VNFS SDK, SDC, ONAP-ETSI Catalog Manager)
  - ONAP shall ingest and interpret a SOL001 compliant VNFD in order to design an ONAP Service (VNFS SDK, SDC)
  - ONAP shall understand resource requirements in the VNFD for each deployment and scaling level (SO, SOL003 Adapter, A&AI, OOF)
  - ONAP shall support a SOL003 compliant SBI to plug in external VNFM (SO, SOL003 Adapter, VF-C)
  - ONAP shall have a mechanism for specifying that a VNF instance should be runtime managed by a particular VNFM type (design time) and instance (run time) (SO, SOL003 Adapter, OOF, A&AI)
  - ONAP shall have a way to inventory a VNF that was deployed using an external VNFM (SO, A&AI)
- External NFVO scenarios :
  - ONAP shall ingest and save (without modification) a SOL007 Network Service Package. (VNFS SDK, SDC) for later consumption by a SOL005 compliant NFVO
  - ONAP shall ingest and interpret a SOL001 compliant NSD (SDC)
  - ONAP shall ingest and save (without modification) a SOL004 CSAR package for later consumption by a SOL003 compliant NFVO (VNFS SDK, SDC, ONAP-ETSI Catalog Manager)
  - ONAP shall ingest and interpret a SOL001 compliant NSD/PNFD in order to design an ONAP Service (VNFS SDK, SDC)
  - ONAP shall be able to convert an ONAP Service into a SOL001 compliant NSD (SOL005 Adapter)
  - ONAP shall have a SOL005 compliant SBI (SO, SOL005 Adapter, VF-C, External NFVO)
  - ONAP shall have a mechanism for specifying that a Service should be runtime managed SO, VF-C or external NFVO (SDC, SO)
  - ONAP shall have a way to inventory a Service that was deployed as a Network Service using an external NFVO (SO, A&AI)
  - ONAP shall be able to design a Service that includes some VNFs and some hierarchy (nested) of Services (NSs) (SDC)
  - ONAP shall have a way to Deploy and Life Cycle Manage a Service that includes some VNFs and some hierarchy of Services (NSs) (SO, A&AI, SND-C, SOL003 & SOL005 Adapters)
- ONAP shall support: 1) VNFM-triggered VNF Configuration, 2) EM-triggered VNF/VNFC LCM and 3) VNF Indicator Interface, based on SOL002 standard (SOL002 Adapter, APPC, DCAE, Policy)

# ETSI MANO and ONAP ETSI Alignment Landscape

As part of aligning ONAP to ETSI MANO, ONAP will support ETSI standards for packaging, operations, security and monitoring for managing VNF, PNF and NS.

- For packaging, the SOL004 standard is used for the VNF and PNF package, and the SOL007 standard will be used for the NS package
- VNF, PNF and NS will be described by the SOL001 standard.
- For VNF LCM, Package Management, LCM operations and Monitoring, the SOL003 standard is used.
- For NS LCM and Package Management, LCM operations and Monitoring, the SOL005 standard is used.
- For EM triggered scenarios (LCM, Fault, Performance, Configuration), the SOL002 standard is used.
- ETSI Package and communication security will be supported.

## ONAP components realization of ETSI MANO

- SDC will realize SOL004 and SOL007 package onboarding, design and distribution functionalities.
- External NFVO and VFC will realize the NFVO functionalities.
- SOL003 Adapter will realize the Or-Vnfm (SOL003) interface.
- SOL005 Adapter will realize the Os-Ma (SOL005) interface.
- SOL002 Adapter will realize the Ve-Vnfm (SOL002) interface.

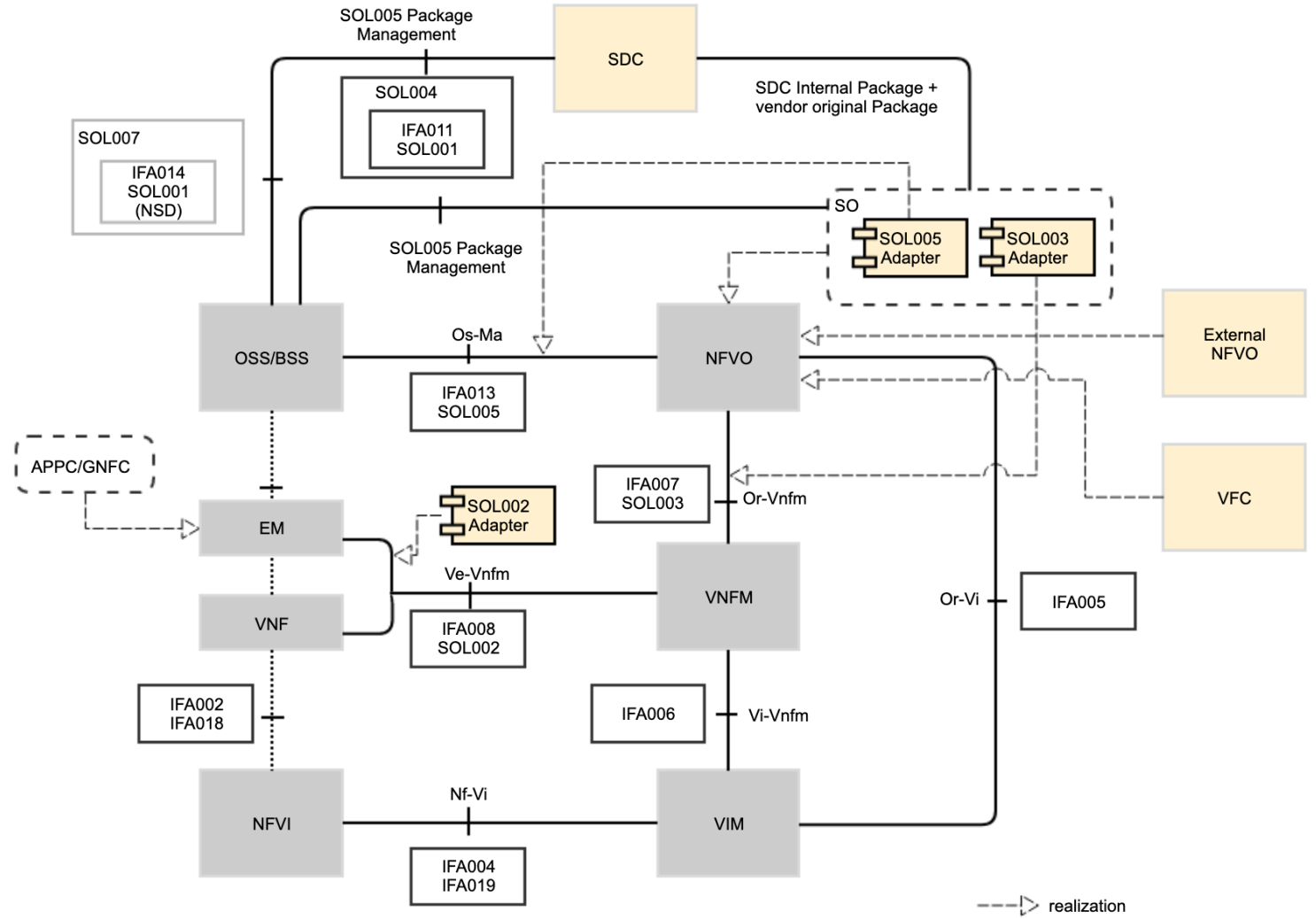



# ONAP ETSI Package Management (Onboarding and Distribution)

## ONAP will support the End-To-End ETSI Package onboarding and distribution.

1. SDC will support SOL004/SOL007 package onboarding, including SOL001 (VNFD/PNFD/NSD)
  - A. SOL004 for VNF and PNF Packages
  - B. SOL007 for NS Packages
  - C. SDC will store the original vendor SOL004/SOL007 CSAR/Zip in the ONBOARDING\_PACKAGE directory
2. SO will get the SDC package which includes the original vendor SOL004/SOL007 CSAR/Zip
3. ONAP-ETSI Catalog Manager will store the original vendor SOL004/SOL007 CSAR/Zip
4. SOL003 Adapter will retrieve the original vendor SOL004 VNF package from the Catalog Manager
5. SOL003 Adapter will forward the original vendor SOL004 VNF package to VNFM
6. SOL005 Adapter will retrieve the original vendor SOL007 NS package from the Catalog Manager
7. SOL005 Adapter will forward the original vendor SOL007 NS package to External NFVO
8. External NFVO will forward the original vendor SOL004 VNF package to VNFM
9. VFC will get the SDC package with the original vendor SOL007 CSAR/Zip from SDC

Note 1: Direct SOL007 NS package onboarding to SO through SOL005 Package APIs is out-of-scope for Frankfurt

Note 2: This architecture also supports the PNF distribution.

ONAP component Impacts: SDC, VNFSDK, SO, ONAP-ETSI Catalog Manager, SOL003/SOL005 Adapters, VFC

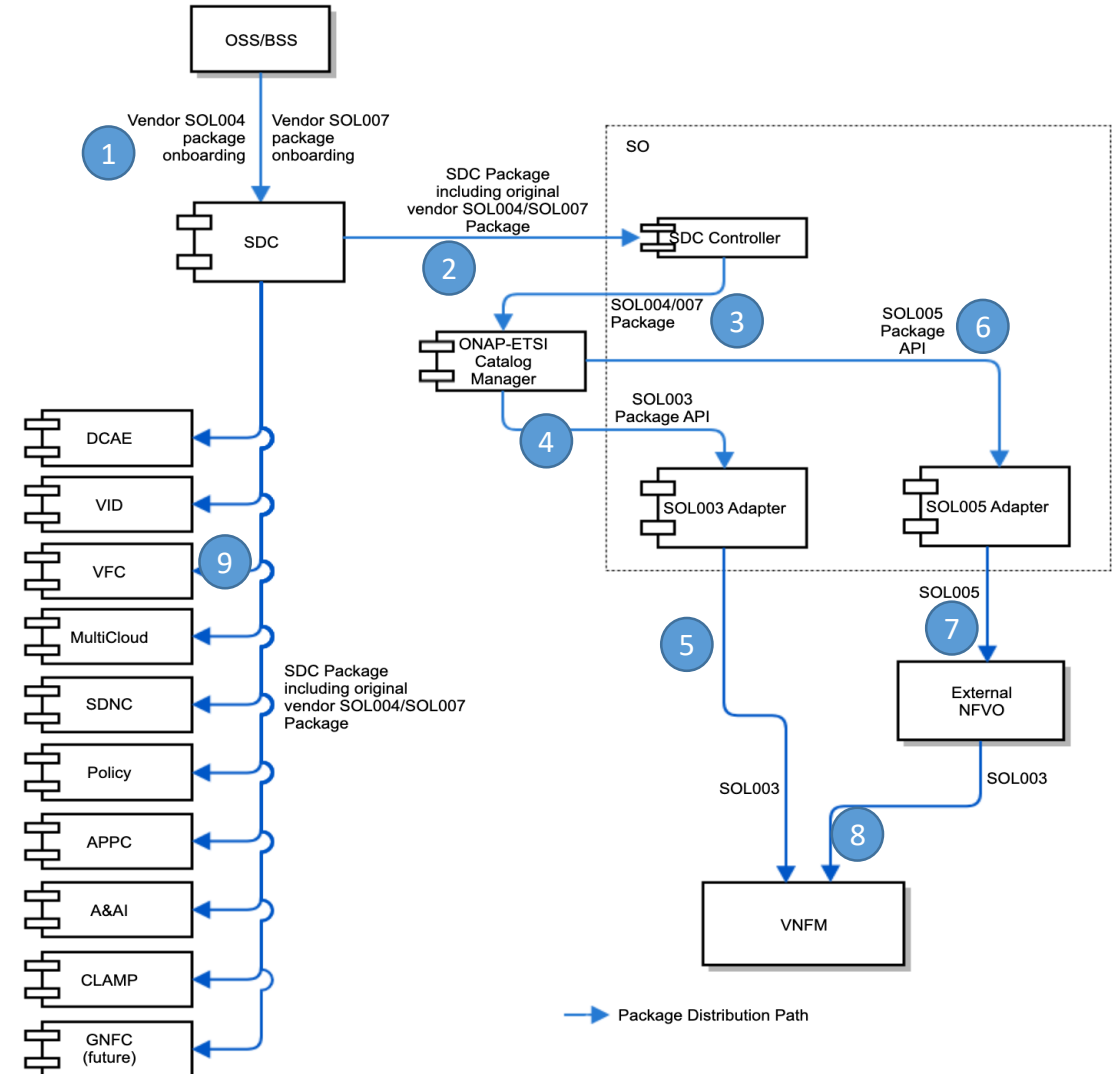



# ONAP ETSI Package Security & Validation

## Based on SEC021, the ETSI Package validation is a must. For that,

- SOL004 VNF/PNF Package security will be supported by the package signature and certificate.
- SOL007 NS Package security will be supported by the package signature and certificate.
- SDC will support the SOL004/SOL007 package security option 2:
  - The complete CSAR file shall be digitally signed with the VNF/NS designer private key.
  - The VNF/NS designer delivers one zip file consisting of the CSAR file, a signature file and a certificate file that includes the VNF/NS designer public key.
- SDC will store the vendor package with vendor-provided signature and certificate in a zip format in the ONBOARDING\_PACKAGE directory.
  - SDC VSP and Resource CSAR files have the ONBOARDING\_PACKAGE, which contains the original vendor VNF/PNF/NS package.
  - For Frankfurt, SDC does not generate its own signature and certificates for package distribution to other ONAP components.
- SO will store the vendor SOL004/SOL007 zip files in the ONAP-ETSI Catalog DB through ONAP-ETSI Catalog Manager APIs.
- SVNFM/NFVO will extract the CSAR file from the vendor package
  - For Frankfurt, extracting the CSAR without validation is allowed

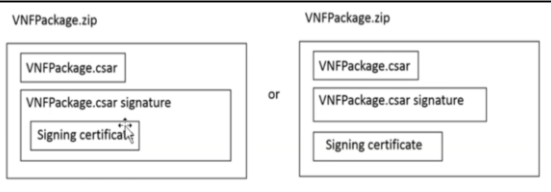

Option 2

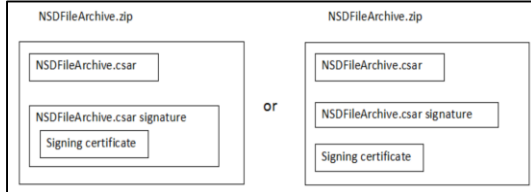

Option 2

## SDC Package Security Validation Process Sequence

- At onboarding, SDC will check the file extension and performs the following procedures
  - If the file is .zip, SDC unzips
    - If it has .cert & .cms, it is a package with security, and security validation will be performed.
    - If it does not include .cert & .cms, it is an existing Heat template onboarding, and SDC follows the Heat template onboarding procedure
  - If the file is .csar, it is a package without security.
- For TOSCA, SDC will check the TOSCA.meta file.
  - If it contains SOL004/SOL007 v2.5/6.1 keywords, the package will be handled as SOL004/SOL007 v2.5/6.1.
  - Otherwise, it will be handled as existing TOSCA (non-SOL004/SOL007) package onboarding which will not have the ONBOARDING\_PACKAGE artifact.

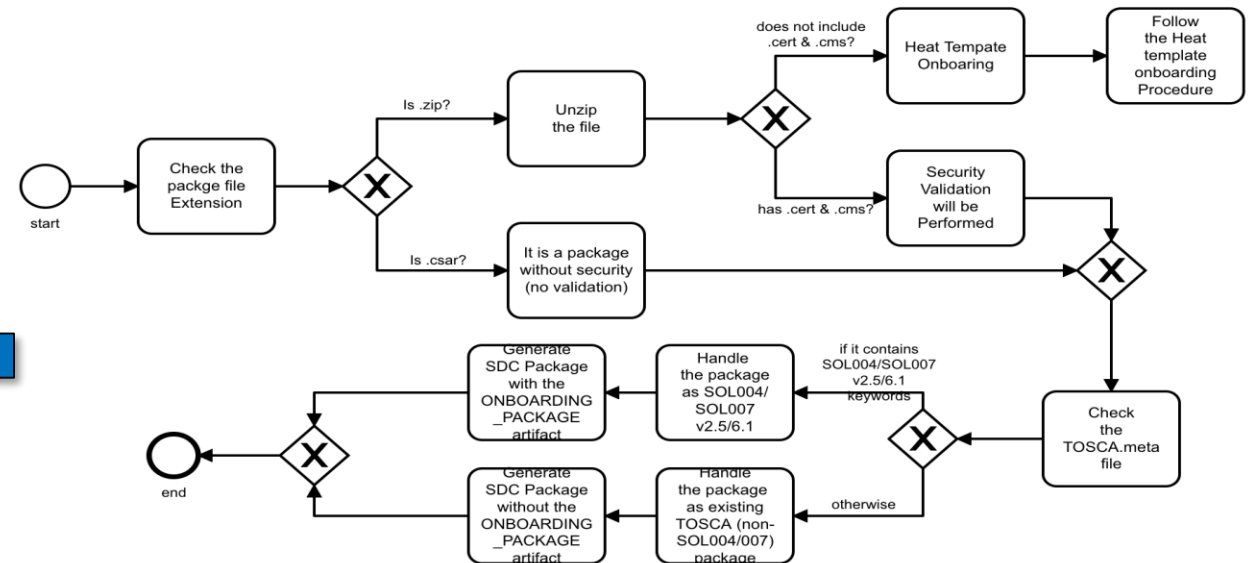

# Communication Security between ONAP and SVNFM/NFVO

- SOL003/SOL005 Adapters will communicate with the SVNFM/NFVO via secured HTTPS protocol with authentication and authorization.
  - SOL003/005 API call security needs to be conformed to OAuth2
  - SOL003/005 Notification call security needs to be conformed to OAuth2 or HTTP Basic authorization (user/pass)
  - SOL003/005 Adapters will leverage the AAF security mechanism (as authorization server)
  - Currently, SOL003 Adapter support one-way and two-way AA.
- SVNFM/NFVO will be allowed to have their own security mechanisms based on their security requirements, but is required to support OAuth2 and HTTP Basic Authentication.
  - Authentication Federation between the Adapters and the SVNFM/NFVO is under discussion.
  - Some vendors prefer SAML-based federation
    - AAF Authentication and External Authentication Server will exchange authentication tokens, based on federation configuration. It depends on AAF.
    - In the Frankfurt release, the authentication federation may not be supported.

Note 1: All SO external interfaces for other ONAP components (e.g., SDC, ONAP-ETSI Catalog Manager, VID, AAI, SDNC, OOF) will be secured in the Frankfurt release by leveraging AAF.

Note 2: SOL002 Adapter will also leverage the AAF security mechanism and will support OAuth2 and HTTP Basic.

Note 3: More communication Security use cases are under discussion.

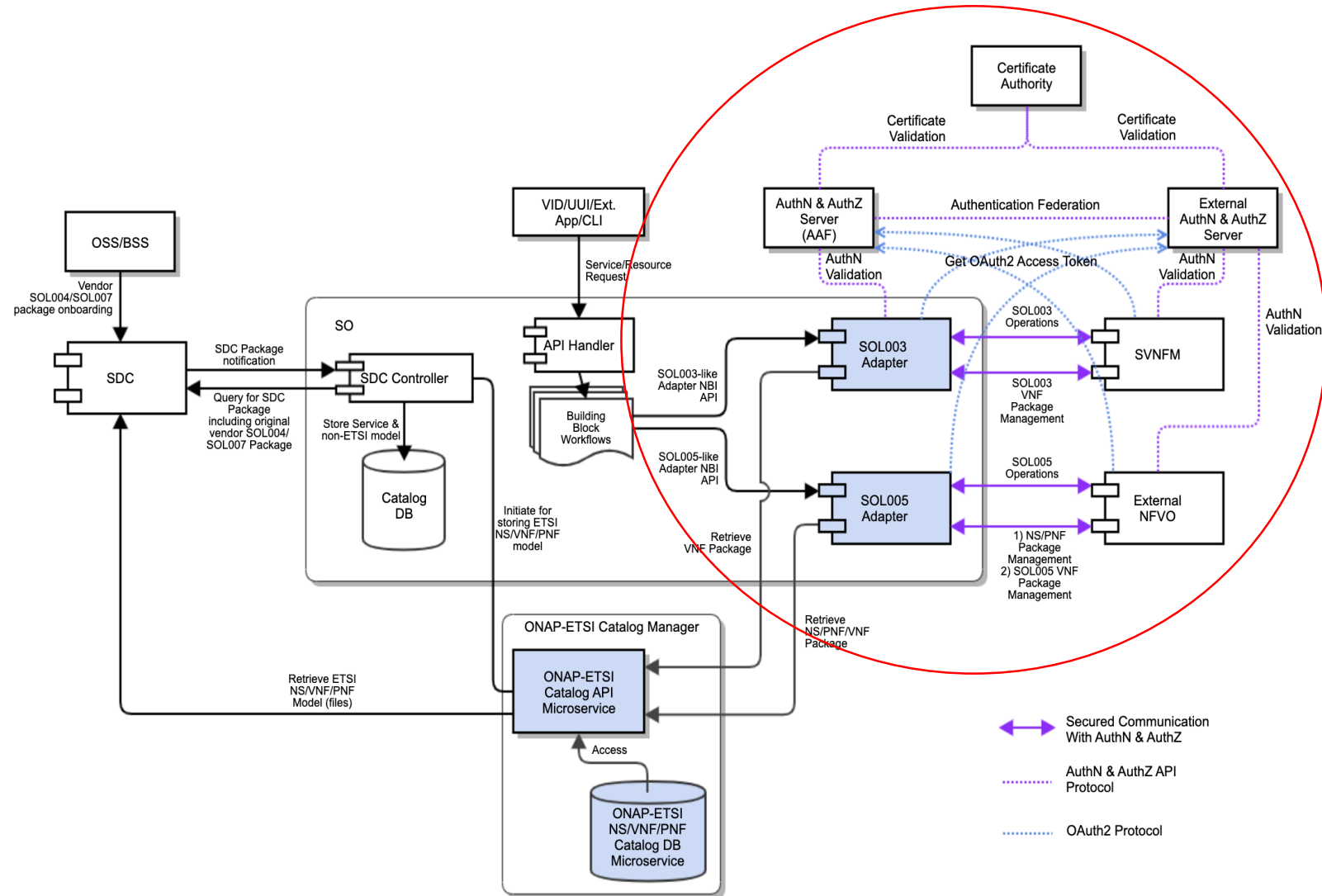



# ONAP ETSI Catalog Management

1. SO (SDC Controller) will query the package from SDC.
2. SO will store ETSI vendor VNF/PNF/NS packages to ONAP-ETSI Catalog Manager
  - A. ONAP-ETSI Catalog Manager APIs will be used for the storage.
  - B. SO will pass the CSAR id to the ONAP-ETSI Catalog Manager, and the Manager will retrieve the CSAR file(s)
3. For Non-ETSI models (Service + Non-ETSI Resource, metadata), SO will use the existing SO embedded Catalog DB
4. ONAP-ETSI Catalog Manager will provide package management APIs and Catalog Database
  - A. Catalog\_NSPackage
  - B. Catalog\_VNFPackage
  - C. Catalog\_PNFPackage
  - D. Catalog\_SoftwareImageModel
5. SOL003/SOL005 Adapter will access ONAP-ETSI Catalog through ONAP-ETSI Catalog Manager APIs
6. SOL003 Adapter will provide SOL003 Package Management APIs to SVNFM
7. SOL005 Adapter will provide SOL005 Package Management APIs to External NFVO

Note 1: PNF package distribution use cases are under discussion.

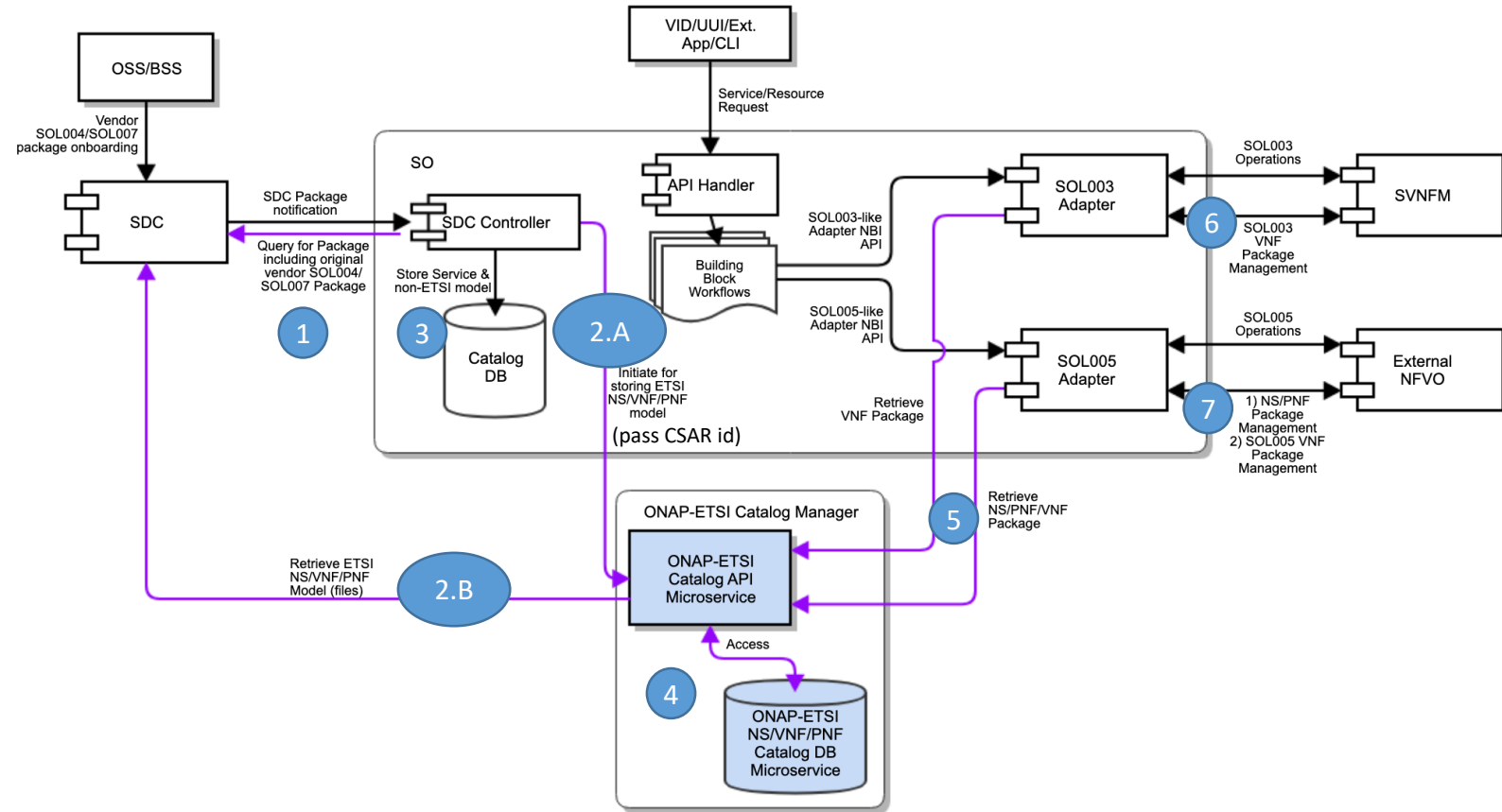

- ONAP-ETSI Catalog Manager deployment location is under discussion.
- The Catalog Manager could be a common component in Frankfurt

# SOL003 Adapter Architecture & Use Cases

- SOL003 Adapter continues to be an SO microservice component.
- SOL003 Adapter will be registered to MSB.
- Operator will register VNFM and VIM to ESR in AAI.
- SOL003 Adapter will expose its NBI to any SOL003 Adapter client in ONAP
  - Interfaces will be refactored to be generic to allow access by other ONAP components.
  - The NBI will be enhanced for additional SOL003 operation support.
- SDC will distribute SDC packages including the vendor original SOL004 (VNF and PNF) and SOL007 (NS) packages.
- SO will leverage ONAP-ETSI Catalog Manager microservice for ETSI-based NS, VNF and PNF storage.
- SO (BPMN) and the SOL003 Adapter client will locate SOL003 Adapter.
- SO (BPMN) and the SOL003 Adapter client will invoke SOL003 Adapter.
- SOL003 Adapter will retrieve VNF package from Catalog Manager.
- SOL003 Adapter will get available VNFM locations (endpoints), and get VIM and VNF Info.
- SOL003 Adapter will select a VNFM, based on a VNFM locating mechanism.
- SOL003 Adapter and SVNFM will support SOL003 VNF LCM, granting and package management operations.
- SOL003 Adapter will support HPA-based Granting, leveraging OOF.
- SOL003 Adapter will update vServer, status and VNF association in AAI
- SOL003 Adapter and SVNFM support authentication and authorization (AAF, and vendor AA mechanism).
- For the integration testing, the VNFM Simulator in the CSIT container will be used.

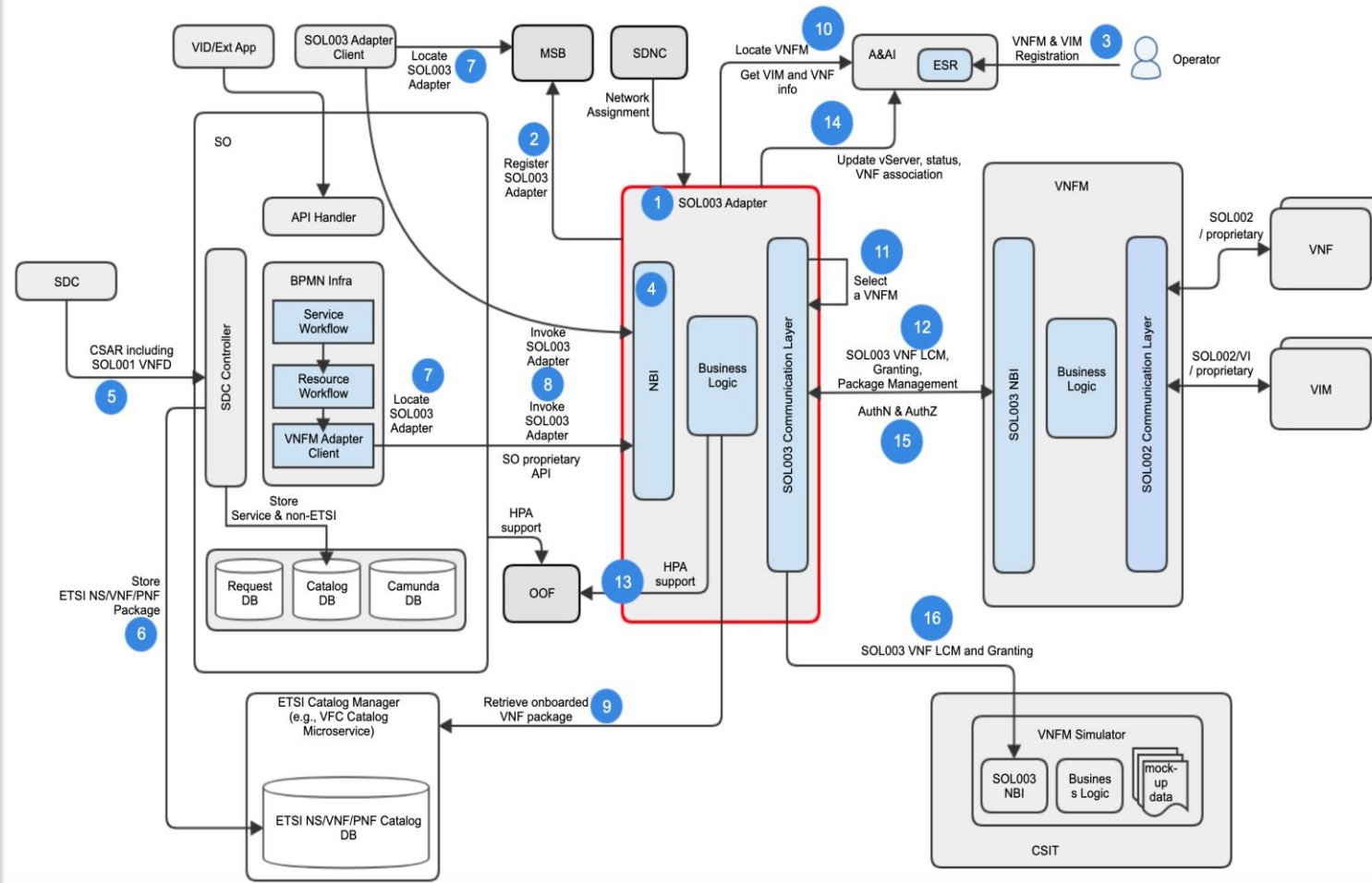

# Granting with HPA, Leveraging OOF

- The SOL003 Adapter will act as an NFVO and support the Synchronous Grant operation with HPA by leveraging OOF.
- Hardware Platform capability requirements will be defined as part of the VNFD data.
- There will be two methods to support HPA in SO:
  - Option 1 (Service-Level Homing) : Use of Homing information that is made during the SO decompose processing.**
    - During SO decompose processing, SO calls OOF for collecting homing information for the service (which includes the VNFs).
    - Call the OOF APIs to perform the optimize service/VNF homing and placement.
    - Use the existing homing workflows to pass hardware platform capability requirements to OOF.
  - Option 2 (VNF-Level Homing): If the above processing does not work for the vendor VNF HPA, OOF will be called from the SOL003 Adapter per VNF granting.**
    - Currently, OOF does NOT support the VNF Level Homing request. OOF API enhancement is requested.
      - OOF needs to enhance their node graph structures for searching for hierarchical service structures.
    - SOL003 Adapter will locate the corresponding Service ID by the VNF name which came from SVNFM. Then, the Adapter will pass service uuid, along with VNF uuid to OOF for homing request.
    - If OOF does not support the VNF-Level Homing request, the option 1 (Service Level Homing) will be used for granting in Frankfurt.
    - VNF-Level Homing request could be useful for scaling or healing that is initiated by VNFs and not associated with a service (see also SOL002 Adapter use cases).

Note 1: SOL002 Adapter will also leverage OOF for HPA.

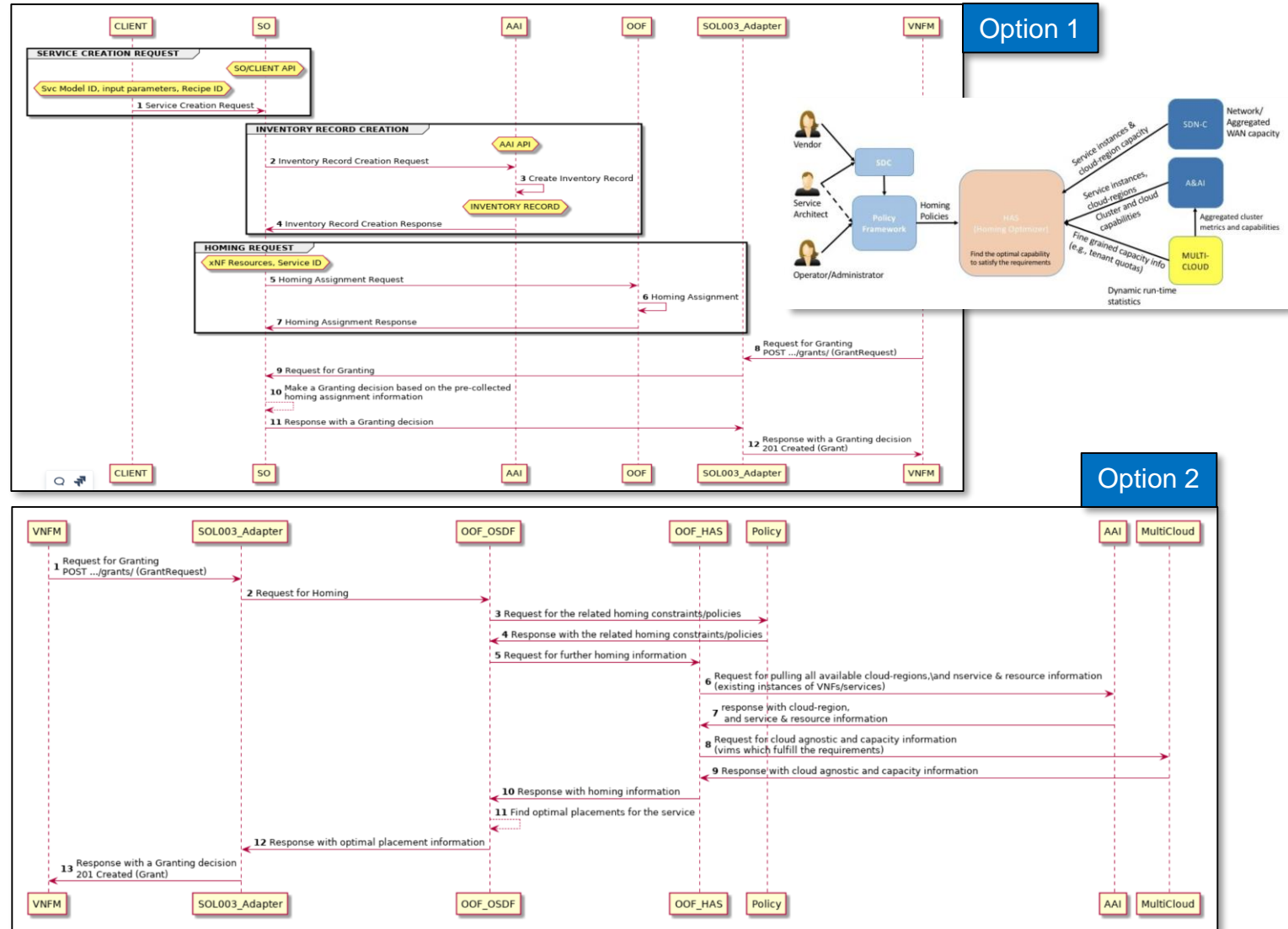

# SOL005 Adapter Architecture & Use Cases

- SOL005 Adapter is a Microservice that will make connections between SO and VF-C/External NFVO through SOL005 standards.
- SOL005 Adapter will support the following APIs in Frankfurt
  - NS LCM : Create NS, Delete NS, Get NS, Instantiate NS, Terminate NS
  - NSD Package Management : Subscribe, Query Subscribe Information, Terminate Subscription, Notify
  - VNFD Package Management : Fetch VNF Package Artifacts, Subscribe, Query Subscription Information, Terminate Subscription
- Use Cases
  - Operator will register NFVO to ONAP via ESR
  - ESR registration entities will be pushed to AAI
  - Operator will send NS requests from UI along with selected NFVO details
  - SOL005 Adapter will fetch NFVO details from AAI
  - SOL005 Adapter will send the requests to NFVO

Note: SOL001 NSD mapping to SDC AID DM is an open issue. The SDC enhancement is requested.

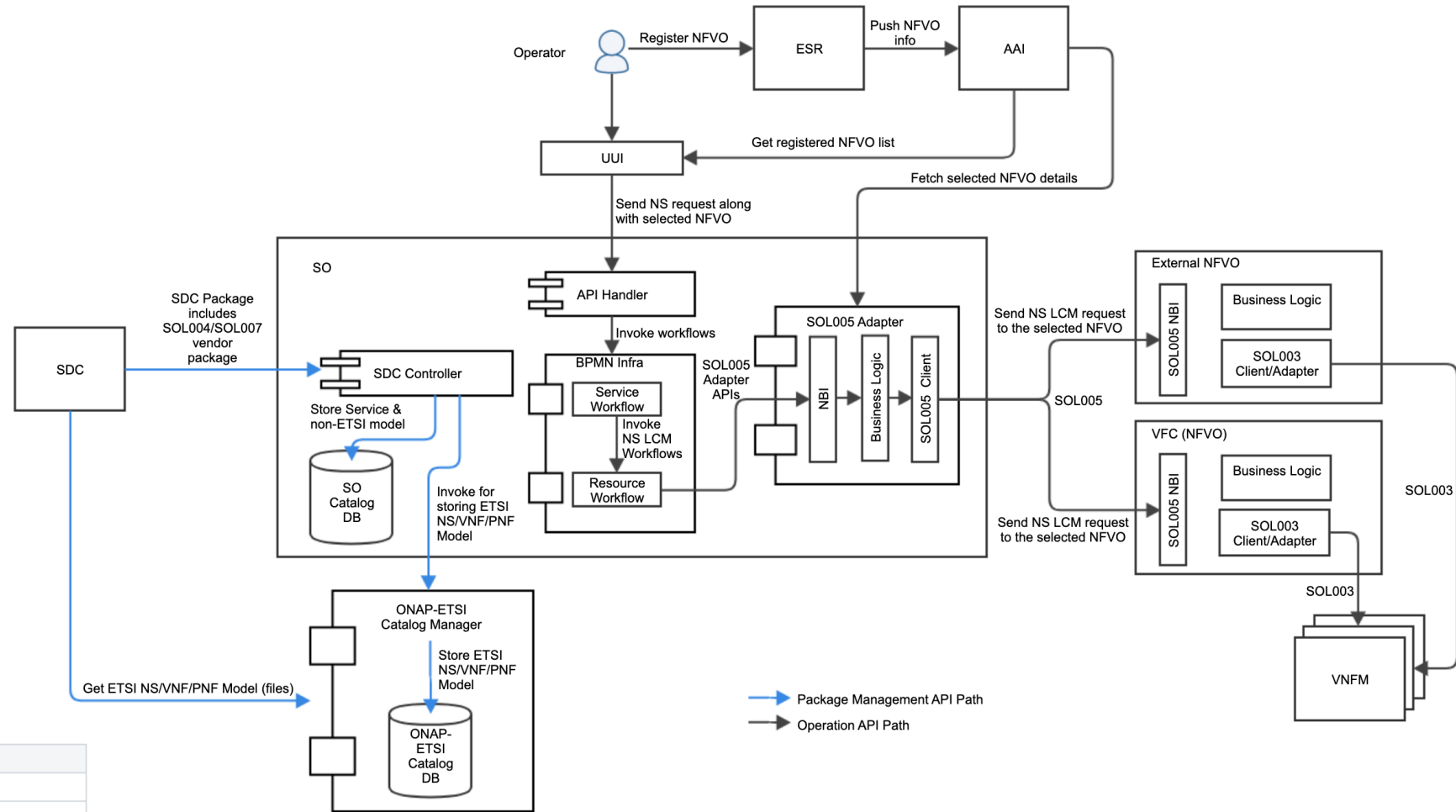

API Action	Method	URI	Description
Create NS	POST	/ns_instances	To create a Network Service
Instantiate NS	POST	/ns_instances/{nsInstanceId}/instantiate	To instantiate Network service
Get NS Details	GET	/ns_instances/{nsInstanceId}	To query the status of the Network Service
Terminate NS	POST	/ns_instances/{nsInstanceId}/terminate	To Delete Network Service Instance

# SOL002 Adapter Architecture & Use Cases

- SOL002 Adapter will be a Microservice that makes connections between VNFM and ONAP (as EM) through SOL002 standards.

- SOL002 Adapter deployment location is under discussion.

- SOL002 Adapter will support the following Use Cases

## 1. VNF Configuration (Ve-Vnfm-em)

- VNFM can set VNF initial configuration using SOL002 VNF Configuration Interface towards EM
- SOL002 Adapter will convert the configuration to another protocol and ONAP Controller enables Operator configurability

## 2. VNF/VNFC LCM (Ve-Vnfm-em)

- LCM Action Execution
  - ONAP Close Loop will be supported (Heal/Scale VNF/VNFC through SOL002)
  - VNF-Level (possibly VNFC-level) Homing requests to OOF would be necessary.
- LCM Notification Subscribing/Consuming
  - SOL002 Adapter will receive VNFM notifications and perform VNF/VNFC LCM and/or VNF/VNFC Configuration.

## 3. VNF Indicator Interface (Ve-Vnfm-em)

- SOL002 Adapter will 1) read VES events, 2) convert the events to SOL002 interface format, and 3) send notification to VNFM

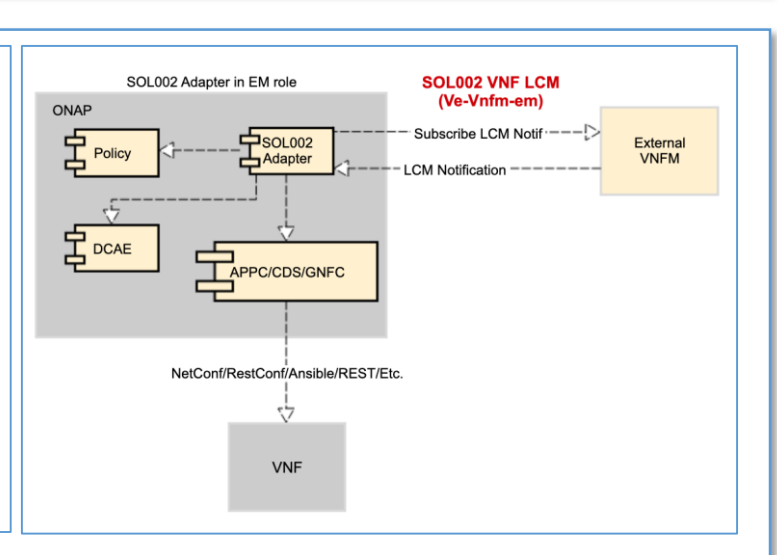
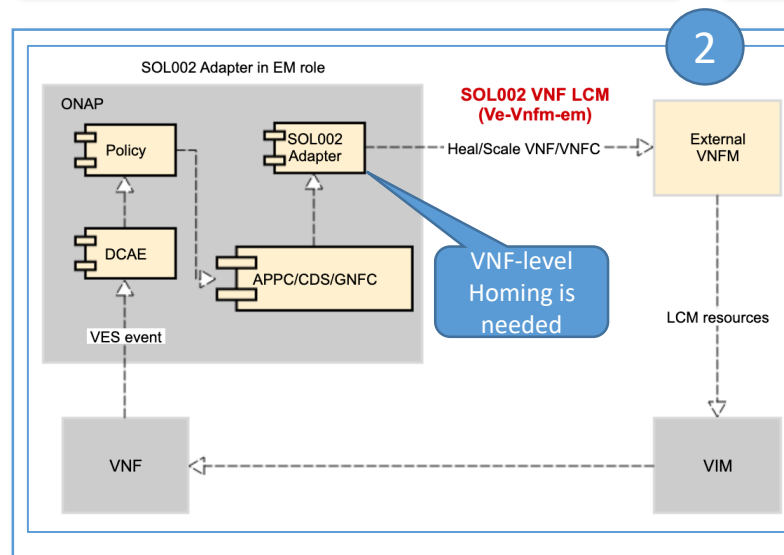
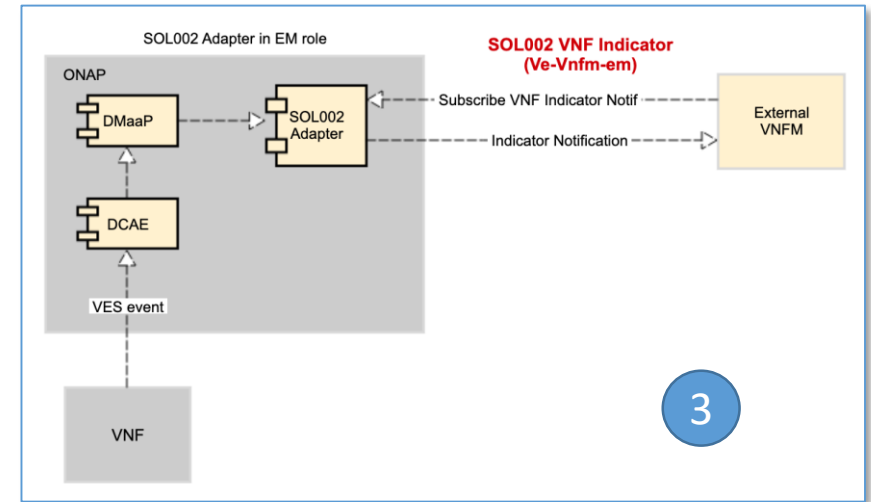
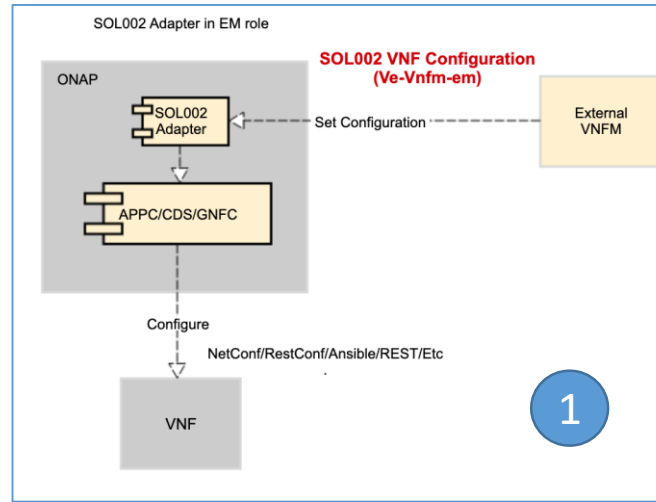



# SOL001 NSD and VNFD Mapping



- Mapping between SOL001 VNFD and SDC AID DM
  - SDC shall support mapping between SOL001 VNFD and SDC AID DM during the VNFD onboarding
  - SOL003 Adapter shall support mapping between SOL001 VNFD and SDC AID DM for SOL003 operations
- Mapping between SOL001 NSD and SDC AID DM
  - SDC shall support mapping between SOL001 NSD and SDC AID DM during the NSD onboarding
  - SOL005 Adapter shall support mapping between SOL001 NSD and SDC AID DM for SOL005 operations

Note 1: SOL003 Adapter will extract SOL003 operation parameters from the SDC VNFD 1/VNFD 1'. Full-blown mapping between the vendor VNFD and the SDC VNFD may not be necessary for the SOL003 operations.

Note 2: SOL005 Adapter will extract SOL005 operation parameters from the SDC NSD 1/NSD 1'. Full-blown mapping between the vendor NSD and the SDC NSD may not be necessary for the SOL005 operations.

Note 3: PND mapping to SDC AID DM (ONAP internal representation) has been done in Dublin, [ONAP R6 Resource IM Call 2019-8-19](#)

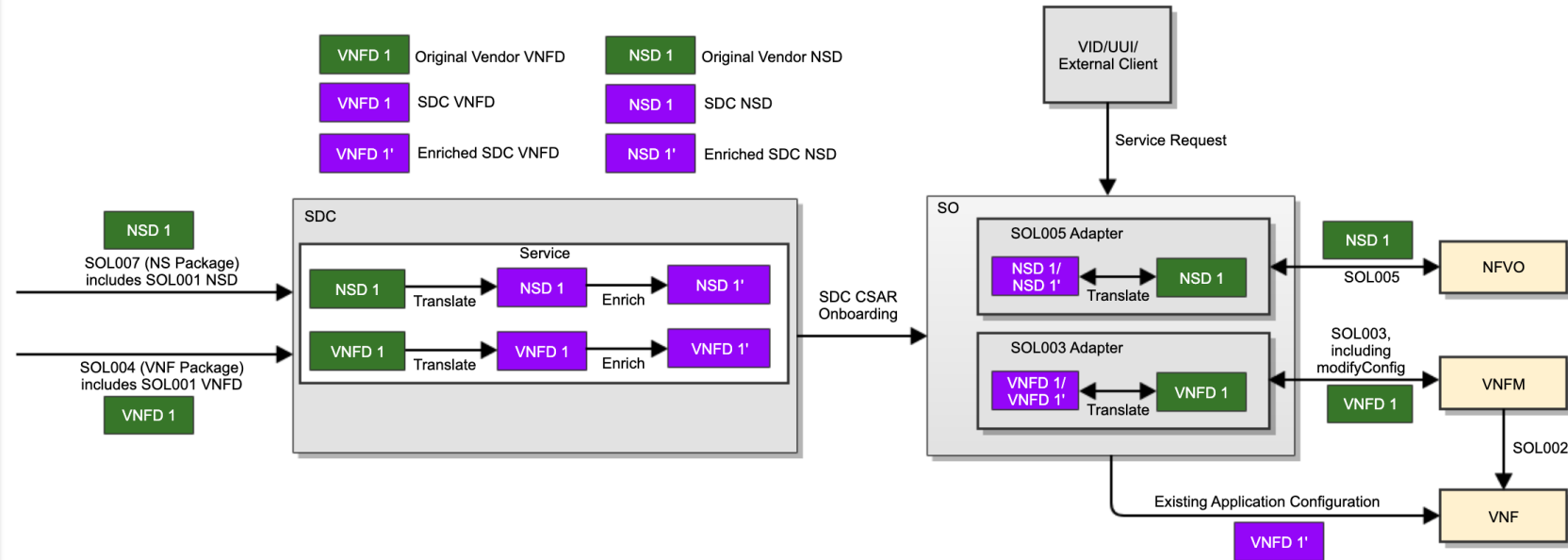



# Open Issues

- SOL001 NSD and VNFD Mapping to SDC AID DM
  - Should SDC allow enrich NSD and VNFD?
- Authentication federation between ONAP AAF and external Authentication Server
- OOF enhancement for VNF-Level Homing Request
- Scaling for VNF vs. VF-Module

# References

- ETSI Alignment Support, <https://wiki.onap.org/display/DW/ETSI+Alignment+Support>
  - ETSI Package Management, <https://wiki.onap.org/display/DW/ETSI+Package+Management>
  - ETSI Catalog Management, <https://wiki.onap.org/display/DW/ETSI+Catalog+Management>
  - Communication Security, <https://wiki.onap.org/display/DW/Communication+Security>
  - SOL003 Adapter, <https://wiki.onap.org/display/DW/SOL003+Adapter>
  - SOL005 Adapter, <https://wiki.onap.org/display/DW/SOL005+Adapter>
  - SOL002 Adapter, <https://wiki.onap.org/display/DW/SOL002+Adapter>
- SOL003 Adapter APIs, <https://wiki.onap.org/display/DW/SO+VNFM+Adapter+APIs>
- SOL003 Adapter Test Case, <https://wiki.onap.org/display/DW/SO+VNFM+Adapter+Test+Case>
- Orchestration Scenarios (a.k.a. ETSI-Alignment) Task Force weekly meeting,
  - Weekly meeting: Mondays at 12PM UTC, 5AM PT, 8AM ET, 2PM CET, 5:30PM India, 8PM China.
  - <https://zoom.us/j/722438866>
  - One tap mobile: +16699006833,,722438866# US (San Jose)      +16465588656,,722438866# US (New York)



**ONAP**

OPEN NETWORK AUTOMATION PLATFORM

Thank you!