

## 5G & PNF Use Cases for R7 GuiLin



- ONAP 5G Use Case Team
- ONAP Subcommittee Meeting Virtual (Apr 21-23, 2020)

ONAP 5G Use Case Team (Presenters / Ben Cheung, Vimal Begwani)

Apr 21, 2020 version 3

# R7 Guilin 5G USE CASE SUMMARY

5G USE CASE	DESCRIPTION	Req vs U/C	5G Specific
<b>BULK PM</b>	Performance Measurements for 5G RAN Bulk Upload with PM Data Control Extension.	Requirements	General
<b>OOF - SON (5G)</b>	Optimization and SON functions for 5G RAN. Self-optimization, Self-Healing, Self-configuration.	Requirements	5G
<b>5G SERVICE MODELING &amp; DEFINITION (5G)</b>	Defining and modeling a 5G Service (in Design Time) and associated Modeling (Platform Info & Data Model).	Requirements	5G
<b>CONFIGURATION &amp; PERSISTENCY SERVICE</b>	Configuration Persistency Service using internal Database for storing Network related data for use in LCM, OSS, Network, Operational applications.	Requirements	General
<b>LICENSING MANAGEMENT</b>	Introduction of Licensing Management driven from MANO ETSI IFA034. Modeling and architecture work to lay the foundation for ONAP & Licensing handling.	Requirements	General
<b>MOBILITY STANDARDS HARMONIZATION</b>	Introducing the capability to receive, validate and process standards defined notifications encapsulated in VES events in ONAP. Also with A1 Adaptor extension.	Requirements	General
<b>5G NRM (CM)</b>	5G Network Resource Model introducing Configuration Management (CM Updates) using RESTful (HTTPS) Interface (instead of NetConf).	Requirements	5G
<b>NETWORK SLICING (5G Use Case)</b>	Network Slicing defines Slices for 5G RAN systems. Network Slicing is a long-lead (multi-release) development. (will be presented in its own lecture at the Virtual Face to Face)	E2E Use Case	5G

# 5G SERVICE CREATION & MODELING in R7 Guilin

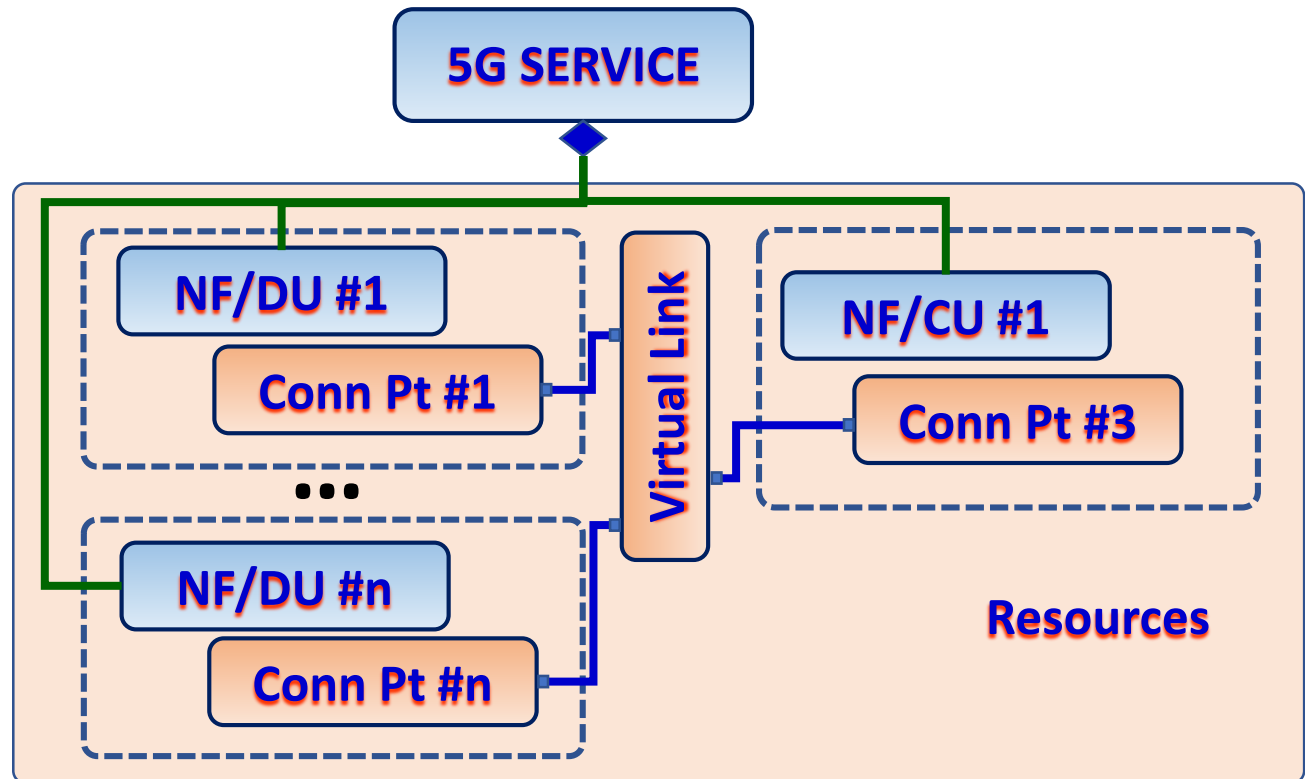
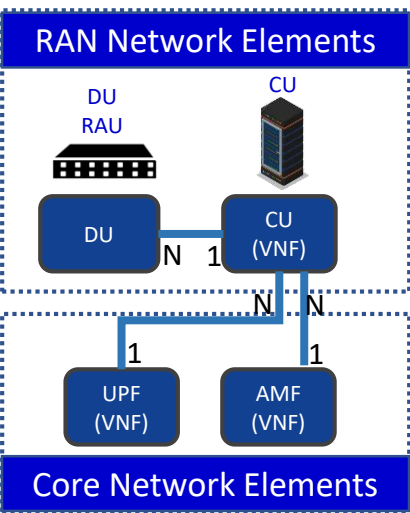
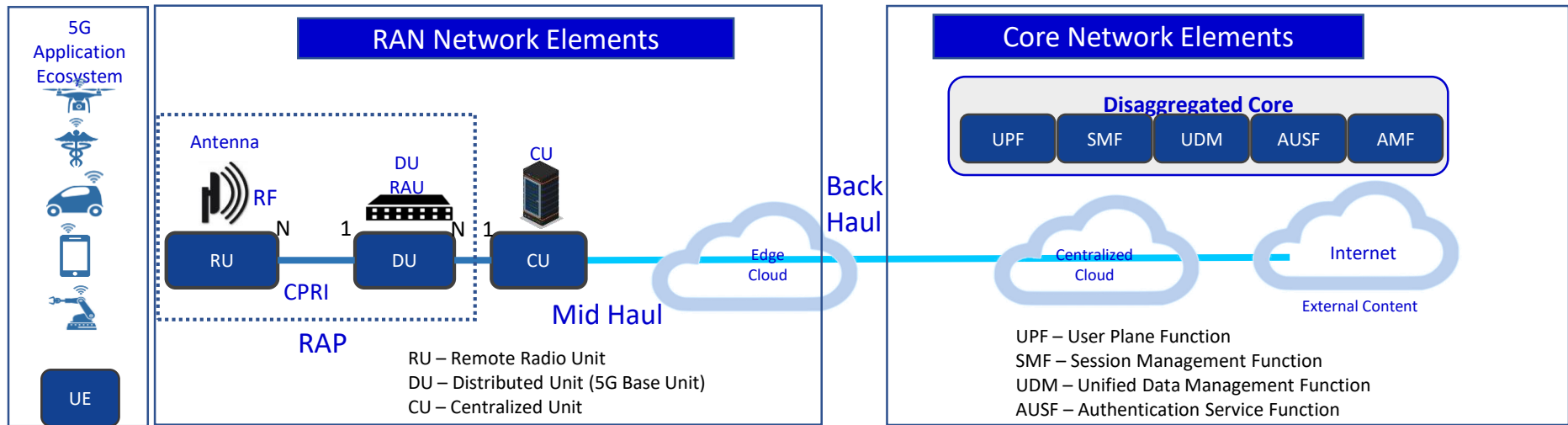

# 5G Service Model & Creation – Business Driver

**EXECUTIVE SUMMARY** - This requirement introduces platform information model enhancements to document new ISOMII experimental classes from 3GPP TS28.541, the 5G Network Resource Model (NRM).

**BUSINESS IMPACT** - The requirement, is a critical because it will serve to lay the ground-work for actually "turning on" a real 5G DU (PNF) that might be installed by a Vendor.

**BUSINESS MARKETS** - This project applies to any domain (wireless, transport, optical, and wireline) that ONAP may manage.

**FUNDING/FINANCIAL IMPACTS** - Without the groundwork laid down for information model management of a 5G Service, operators will not be able to "turn on" a real live 5G network using "live" PNF resources. No Network. No Business. High OPEX impact.

**ORGANIZATION MGMT, SALES STRATEGIES** - There is no additional organizational management or sales strategies for this use case outside of a service providers "normal" ONAP deployment and its attendant organizational resources from a service provider.

3GPP TS 28.541 V15.4.0 (2019-09)

Technical Specification

3rd Generation Partnership Project;  
Technical Specification Group Services and System Aspects;  
Management and orchestration;  
5G Network Resource Model (NRM);  
Stage 2 and stage 3  
(Release 15)

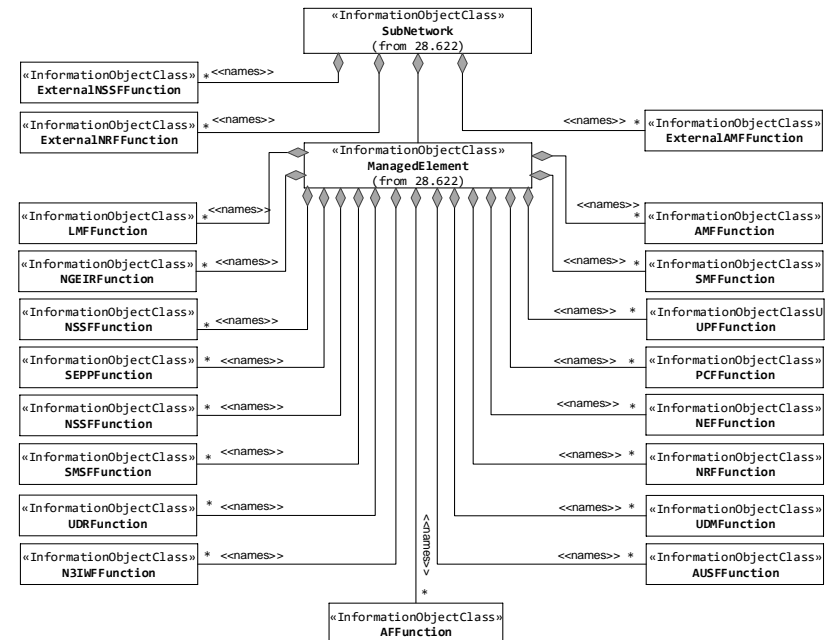

# 5G SERVICE CREATION & MODELING in R7 Guilin

This Use Case will introduce support for 5G Service creation and modeling

<https://wiki.onap.org/pages/viewpage.action?pageId=60888132>

R7 CANDIDATE ENHANCEMENTS	IMPACT
Modelling S/C	Evolution of Platform Info & Data model in support of 5G Service Service from 3GPP TS28.540 and TS28.541 5G NRM standards for modeling a service (might need alignment). Platform data/information model.  To introduce one object from the 3GPP TS28.541. even if it is ISOMII Experimental

U/C DESCRIPTION

Wiki

R7 Guilin CANDIDATE ENHANCEMENTS

# Bulk PM (Perf3gpp Event Generation)

## Bulk PM File Upload and Perf3gpp Event Generation

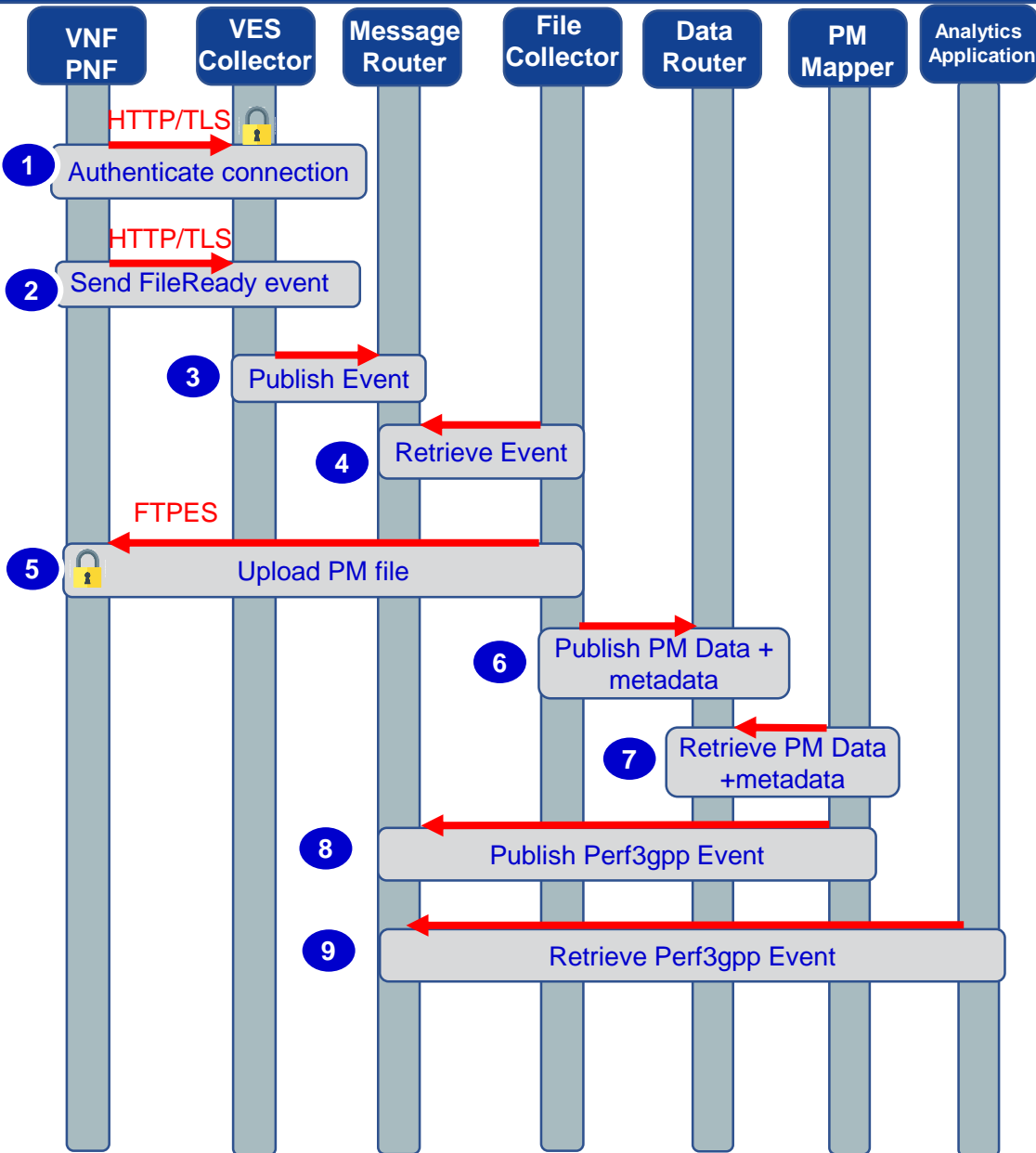

## Bulk PM File Upload and Performance Event Generation

- 1** Network Function (NF) establishes a HTTP/TLS connection to the DCAE VES Collector.
- 2** NF sends FileReady notification Event to DCAE VES Collector. Event is encoded in JSON and sent via HTTP/TLS. HTTP/TLS connection is set up and torn down every time a FileReady notification event is sent.
- 3** DCAE VES Collector publishes the event to on DMaaP Message Router (MR).
- 4** DCAE File Collector retrieves the FileReady notification event from DMaaP MR.
- 5** File Collector uploads PM File from NF using a secure file transfer protocol; FTPES supported in Casablanca. NF authenticates the connection.
- 6** File Collector publishes PM Data to DMaaP Data Router (DR).
- 7** PM Mapper retrieves PM Data from DR and generates Perf3gpp events as configured by PM Mapper File.
- 8** PM Mapper publishes Perf3gpp events to MR.
- 9** Analytics Applications (AA) retrieve the Perf3gpp events of interest from MR. AA analyze the data to produce statistics and KPIs and optimization recommendations.

# Bulk PM for R7 Guilin

Support the following work items for Bulk PM for 5G xNFs:

1. UC1: Perf3gpp event creation by 3GPP PM Mapper from Bulk PM XML file
2. UC2: Closed Loop support using 3GPP PM data (stretch goal)
3. Additional Requirements: DFC robustness enhancements, DMaaP DR enhancements
4. Expand to include control plane performance data

<https://wiki.onap.org/pages/viewpage.action?pageId=40206494>

## R7 CANDIDATE ENHANCEMENTS

## DESCRIPTION

### PM Data Control Extension

PM data collection control provides 5G network operators with a dynamic and more efficient way to configure performance measurement collection on a selected subset of PNFs/VNFs in the network and complements the existing PM data collection and processing capabilities in ONAP/DCAE. An initial version has been delivered in Rel 6 (5G / Bulk PM / PM Control - REQ-129). Planned enhancements for Rel 7 intend to further increase the capability and the dynamicity of this feature.



# 5G Self-Organizing Network using OOF in R7 Guilin

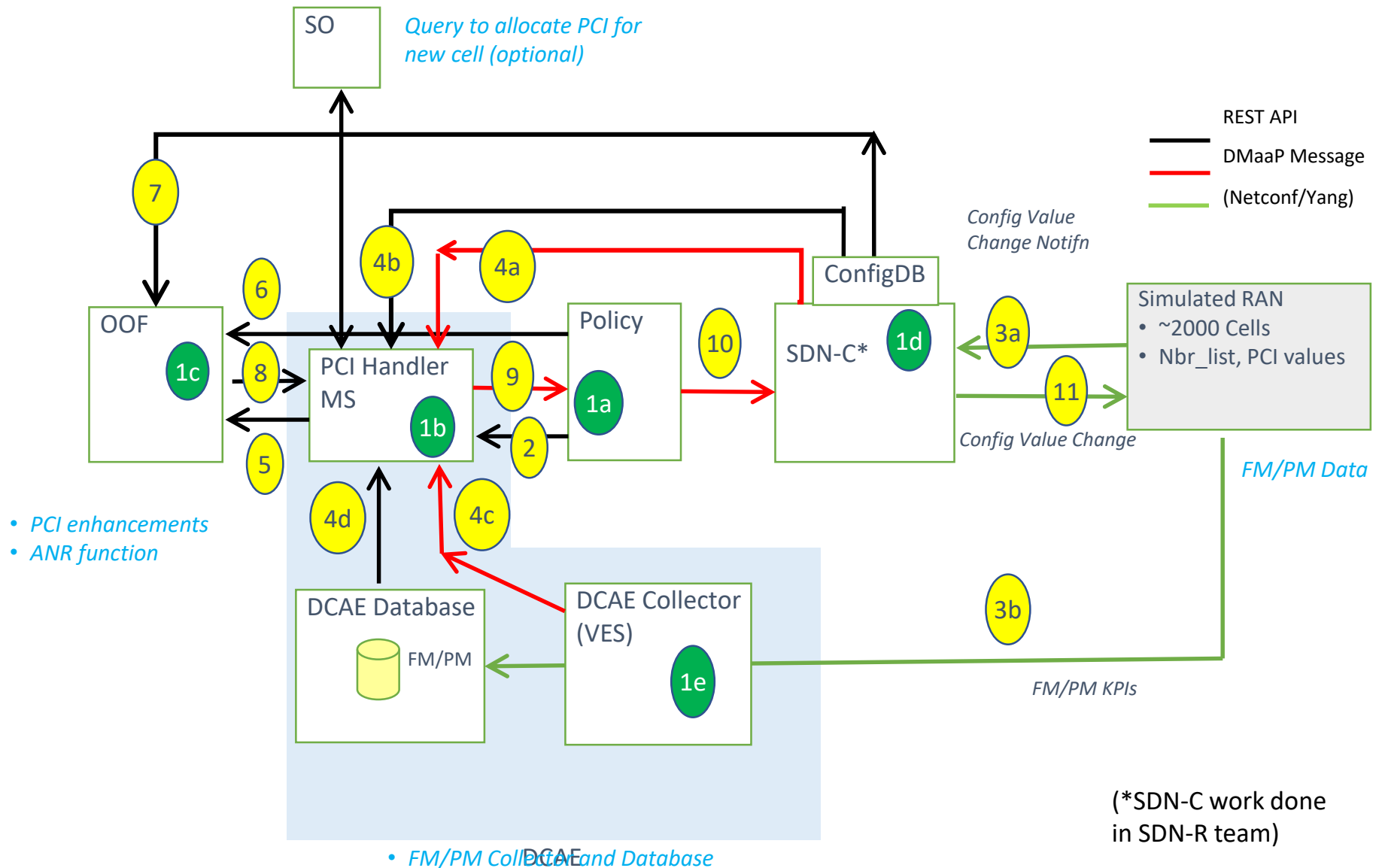



# 5G Self-Organizing Network using OOF in R7 Guilin

## Key areas for requirements & functions for SON/OOF in R7

O-RAN alignment (VES, O1 interface)	Receive Configuration Management (CM) notifications over VES (instead of netconf)
RAN Database (Runtime Config DB), including any new RAN models	<ol style="list-style-type: none"> <li>1. Data models/DB schema and APIs to be generated from yang models</li> <li>2. Details of cells to be stored with PNF reference in AAI</li> <li>3. Modeling of RAN functions and objects</li> </ol>
Control Loop Coordination (CLC) extensions	Collaborate on CLC extensions (queueing, priority, ...)
Integration of SON and PNF onboarding functions	<ol style="list-style-type: none"> <li>1. New cell(s) addition – extension to PNF onboarding &amp; registration scenario, addition of new cell later to a PNF</li> <li>2. Initial assignment of PCI to a cell</li> </ol>
New SON function to evolve ONAP platform	<ol style="list-style-type: none"> <li>1. SON based on data/KPI analysis</li> <li>2. CLC interaction</li> <li>3. Machine Learning (ML) aspects in DCAE</li> </ol>
SON Lifecycle	Role of SO, SDC, CLAMP (for SON service/feature deployment)
Real GNB interaction	Interaction with real GNBs

<https://wiki.onap.org/display/DW/OOF+PCN+Use+Case+--+Dublin+Release>

U/C DESCRIPTION

Wiki

R7 Guilin CANDIDATE ENHANCEMENTS

R7 ENHANCEMENTS	IMPACT
OOF	<ul style="list-style-type: none"> <li>• Optimization enhancements</li> </ul>
SDN-R	<ul style="list-style-type: none"> <li>• Enhance Yang model to align with 3GPP and O-RAN</li> <li>• Receive Configuration Management (CM) notifications over VES</li> <li>• Align with CPS interface</li> </ul>
DCAE	<ul style="list-style-type: none"> <li>• SON based on data/KPI analysis</li> <li>• Machine Learning (ML) aspects in DCAE</li> <li>• CLC interaction</li> </ul>
POLICY	<ul style="list-style-type: none"> <li>• Collaborate on CLC extensions (queueing, priority, ...)</li> <li>• Enhancements to Frankfurt implementation related to SON Control loops</li> </ul>
SO	<ul style="list-style-type: none"> <li>• PNF onboarding &amp; registration scenario, addition of new cell later to a PNF</li> <li>• Trigger OOF for assignment of PCI to a new cell</li> </ul>
CPS (Configuration & Persistency Service)	<ul style="list-style-type: none"> <li>• Data models/DB schema and APIs to be generated from yang models</li> <li>• Details of cells to be stored in CPS, along with reference to PNF in AAI</li> <li>• Modeling of RAN functions and objects</li> </ul>
RAN-Simulators	<ul style="list-style-type: none"> <li>• CM-Notify sending over VES, reporting of necessary PM/FM data</li> </ul>

# LICENSING MANAGEMENT in R7 Guilin

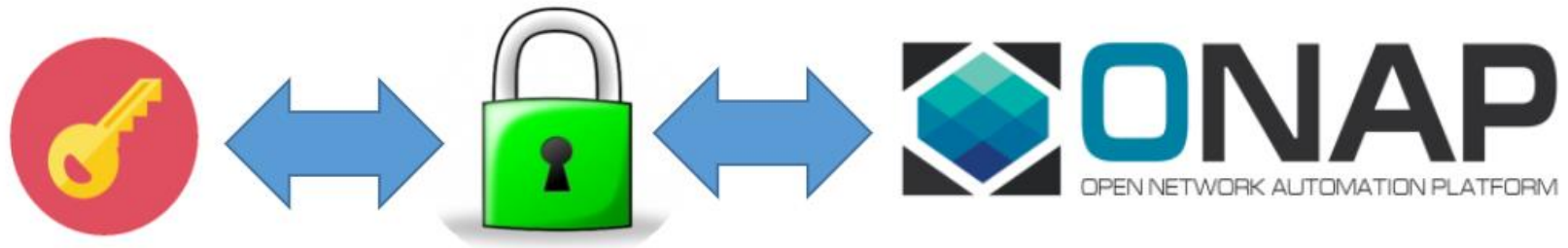

# LICENSING MANAGEMENT in R7 Guilin

## Licensing Management in R7

- 1) Continue use case analysis for xNF License Management and derive any requirements to ONAP. The aim is for ONAP to support various types (simple, complex, vendor specific) commercial licensing models and use cases. The use cases we started with include xNF onboarding, PNF introduction/ONAP PnP, VNF instantiation. Further use cases to be analyzed. Based on agreed use cases review relevant ONAP xNF requirements. Possible contributions to SDC, as well as enhancement of ONAP architecture sequence diagrams.

<https://wiki.onap.org/display/DW/LICENSING+MANAGEMENT>

### R7 CANDIDATE ENHANCEMENTS

### IMPACT

Modeling

Modeling work to integrate changes already introduced from the modeling s/c for licensing with MANO ETSI IFA034 and architecture work from this use case

Architecture

Define an architecture that supports simple or complex, vendor specific Commercial Licensing Models and Use Cases. Investigation of MANO ETSI IFA034 standards with what should be adopted by ONAP. Define the license management principles w.r.t. the key UCs: xNF onboarding, PNF introduction / ONAP PnP, VNF instantiation

VNF-RQTS

Define appropriate new requirements in the VNF-Reqs project related to the new licensing management architecture

Plug and Play

Introduce Plug and Play flow to support Licensing distribution from service

# MOBILITY STANDARDS HARMONIZATION in R7 Guilin

Logical Architecture of O-RAN—ONAP as O-RAN compliant SMO

ONAP is concerned with O1, O2 and A1 interfaces ONLY.

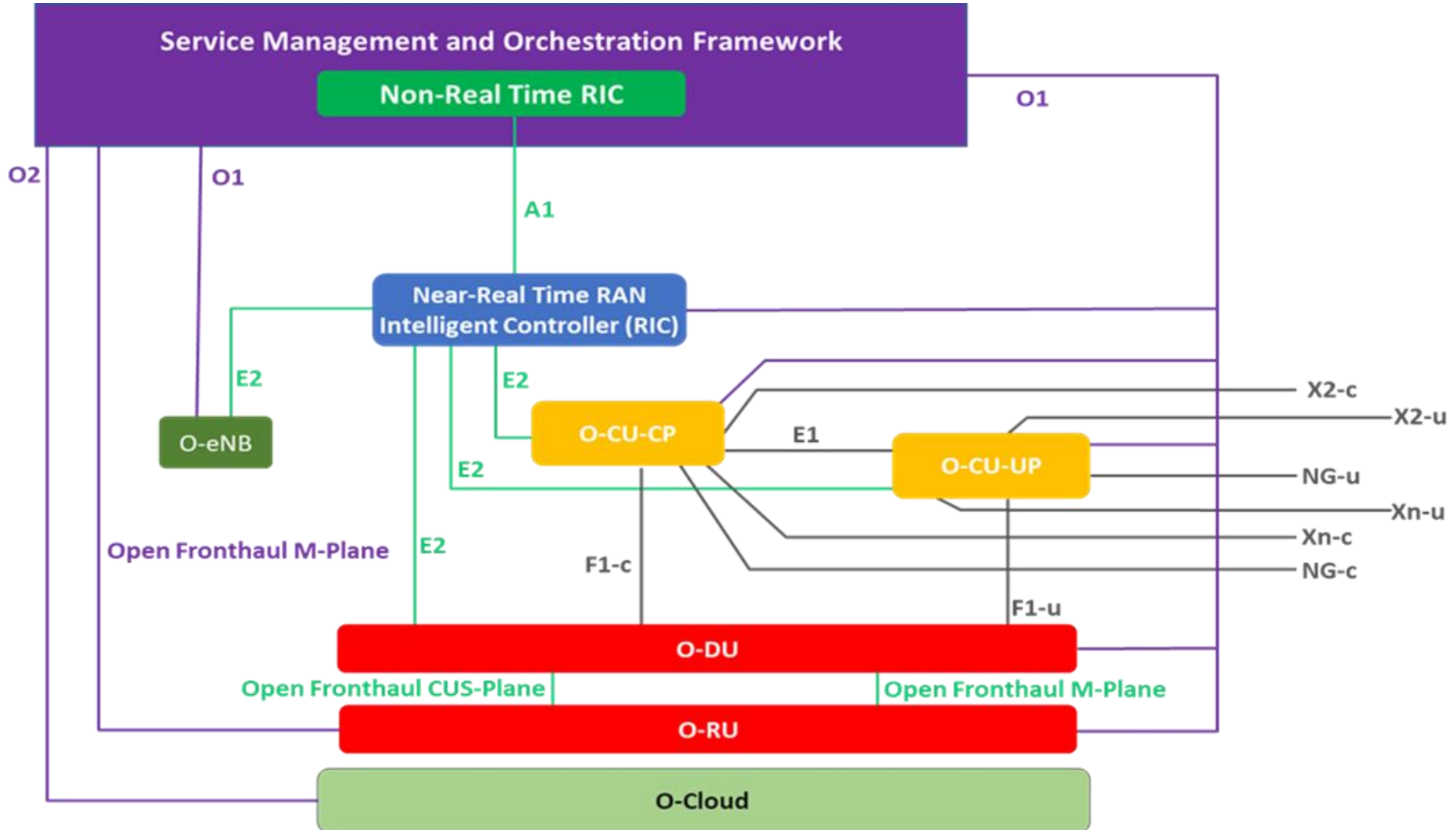

# Mobility Standards Harmonization – *Standards Defined* Event in VES

## Guilin Enhancements

- 1) Introduce the ability to receive and route events defined by a standards organization (3GPP, IETF etc.) encapsulated in a VES event to an appropriate DMaaP topic
- 2) Provide the optional capability to provide a second stage of validation within DCAE prior to the DCAE responding to the NF to validate the contents of the event against valid schema defined by the standards organization.
- 3) The first use case supported will be the processing of 3GPP defined notifications defined in TS 28.532 encapsulated in VES events

[Need a link we don't have a WIKI page for Guilin for this](#)

### R7 CANDIDATE ENHANCEMENTS

### IMPACT

Add a new domain in DCAE/VES Event Listener, to identify that the data carried in the event is defined by a standards organization. Add a field in the VES Common Header to further identify the routing path for the event.

Additional domain supported in the ENUM in DCAE. VES specification updates to document the new domain. To properly identify this event this enhancement would also introduce a new field in the VES Common Header to facilitate the proper routing of the event. The allowed content of this field would be specified by the standards organization that defined the notification and would not be part of the requirements in the VES specification. The VES specification would provide a reference to the document that contains the standardized information to be populated in that field.

Provide second stage validation of the data carried in the proposed stndDefinedFields structure of the event.

Introduce a schema broker in DCAE that will contain valid standards defined JSON schemas that can be used to validate the data in the standards defined event. Propose to extend existing DCAE CBS component to store valid, standards defined JSON schemas. Propose to extend existing DCAE components to allow for a second stage of validation.

# Mobility Standard Harmonization - A1 Adaptor Extension

## Mobility Standards Harmonization – A1 Adaptor Extension

This requirement enhances the A1 adapter/interface capabilities provided in Rel 6 as part of 5G/ORAN & 3GPP Standards Harmonization requirement (REQ-38). O-RAN has defined A1 interface specification in the context of the management of 5G RAN elements to provide intent based policies for optimization of the RAN network performance. Planned enhancements for Rel 7 include additional support for managing A1 Policies, multiple A1 targets in the RAN, multi-version support for different A1 targets, and secure TLS communication.  
(John Keeney, Michela Bevilacqua)

[Need a link we don't have a WIKI page for Guilin for this](#)

### R7 CANDIDATE ENHANCEMENTS

### IMPACT

A1 Adaptor Extension

This requirement enhances the A1 adapter/interface capabilities provided in Rel 6 as part of 5G/ORAN & 3GPP Standards Harmonization requirement (REQ-38). O-RAN has defined A1 interface specification in the context of the management of 5G RAN elements to provide intent based policies for optimization of the RAN network performance. Planned enhancements for Rel 7 include additional support for managing A1 Policies, multiple A1 targets in the RAN, multi-version support for different A1 targets, and secure TLS communication.

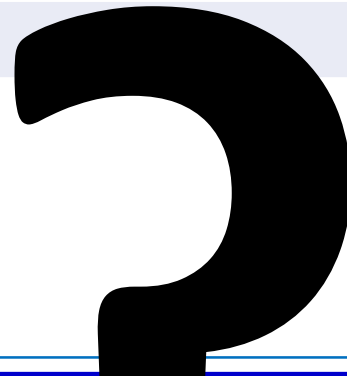

U/C DESCRIPTION

Wiki

R7 Guilin CANDIDATE ENHANCEMENTS

# 5G Network Resource Model (NRM) in R7 Guilin

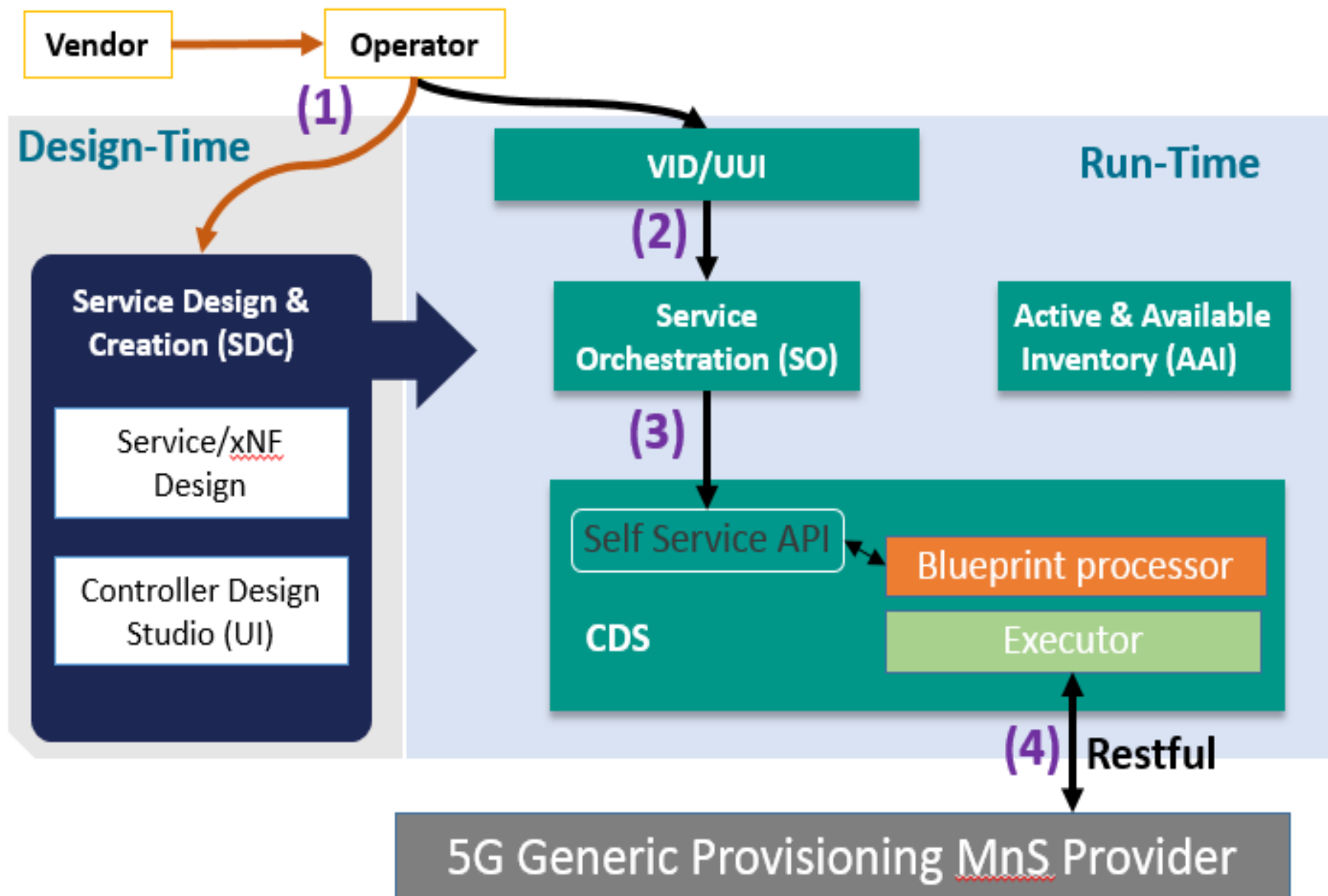

# 5G Network Resource Model (NRM) in R7 Guilin

## New Use Case

- 1) This use case introduces 5G NRM Configuration Management using a RESTful/HTTPS protocol (instead of NetConf). Certainly some corresponding work need to be done in Integration, such as the provisioning MnS provider (Simulator) and documentation. Good news is we complete all implementation and test cases (tested via CLI, actually that is CDS self-service API).

<https://wiki.onap.org/display/DW/5G+Network+Resource+Model+%28NRM%29+Configuration+in+R6+Frankfurt>

## R7 CANDIDATE ENHANCEMENTS

## IMPACT

SO

Add new NRM related data types, corresponding PNF packages and BPMN enhancements as well  
Use several NR NRM IOCs for demonstrations and enhance the PNFD model  
BPMN support for NRM configuration

SO

Support SO service/instance management API for NRM configuration  
Modify or Add additional SO NB APIs  
Define corresponding NRM IOCs in SO and BBs

U/C DESCRIPTION

Wiki

R7 Guilin CANDIDATE ENHANCEMENTS



# Configuration Persistency Service (RTCDDB) in R7 Guilin

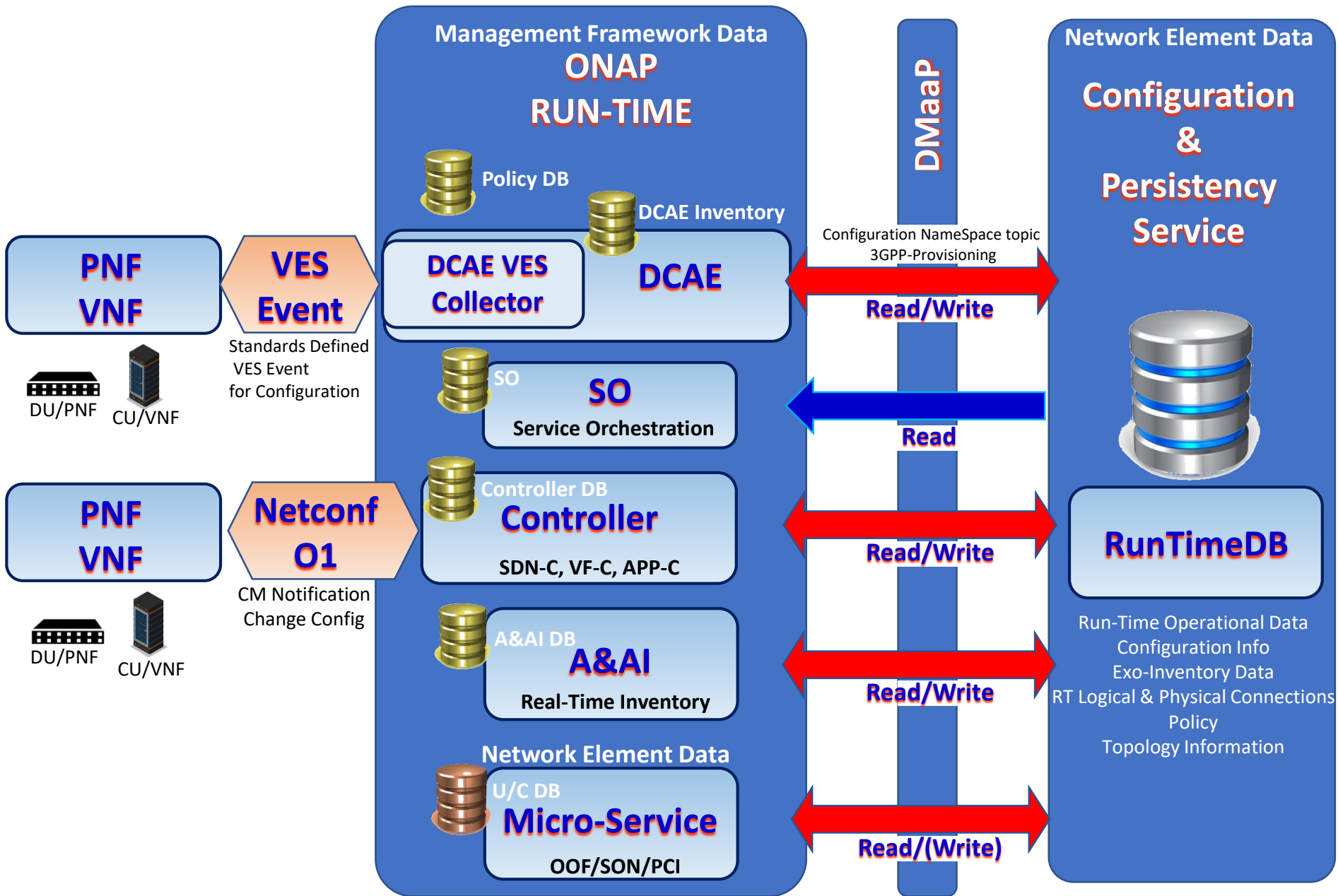

# Configuration & Persistency Service in R7 Guilin

## Data Persistency Service / RunTime Config DB Use Case

- 1) REPOSITORY - The types of data that is stored in the Run-Time data storage repository for:
- (1) CONFIGURATION PARAMETERS used by xNFs in run time. For example 5G Network run-time instance configuration information.
  - (2) OPERATIONAL PARAMETERS used by ONAP and xNFs. Exo-inventory information is information that doesn't belong in A&AI.
- 1) DATA LAKE - It is designed to be a common services data layer which can serve as a data lake.
- 2) SYNCING - The RunTime DB enables the ability to sync data between ONAP & the xNFs. (The source of truth can be define).

<https://wiki.onap.org/pages/viewpage.action?pageId=64003184>

R7 CANDIDATE ENHANCEMENTS	IMPACT
Controller	<ol style="list-style-type: none"> <li>1. Provide yang model and database schema setup.</li> <li>2. NetConf "path" - PNF through Netconf to update database.</li> </ol>
DCAE	<ol style="list-style-type: none"> <li>1. Using the 3GPP Standards-defined VES Event to send Configuration data</li> <li>2. VES listener update/DCAE Pathway for 3GPP config notification</li> <li>3. DMaAP Development to publish on 3GPP-Provisioning NameSpace</li> </ol>
Modeling	Design time support for dynamic database schema setup
A&AI	A&AI Element Sync (new/delete xNF, initial "getall")
Database Development	API Updates, Interface to CPS Database.
New Platform Component	<p>Configuration &amp; Persistency Service (CPS) would be its own Platform Component in R7 Project proposal</p> <p><a href="https://wiki.onap.org/pages/viewpage.action?pageId=71834216">https://wiki.onap.org/pages/viewpage.action?pageId=71834216</a></p>

# NETWORK SLICING in R7 Guilin

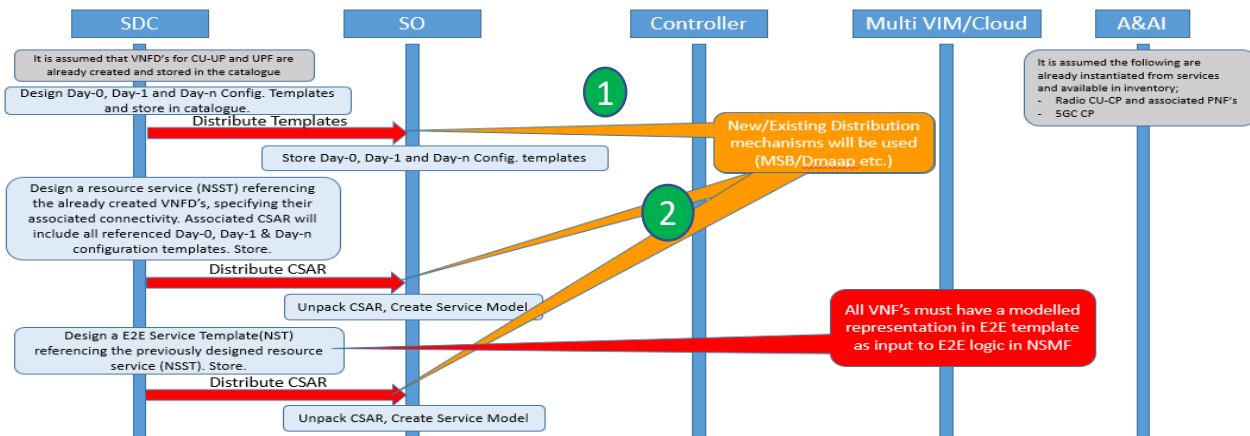

## Design Time

1. Configuration templates are designed and distributed.
2. Service templates are designed and distributed

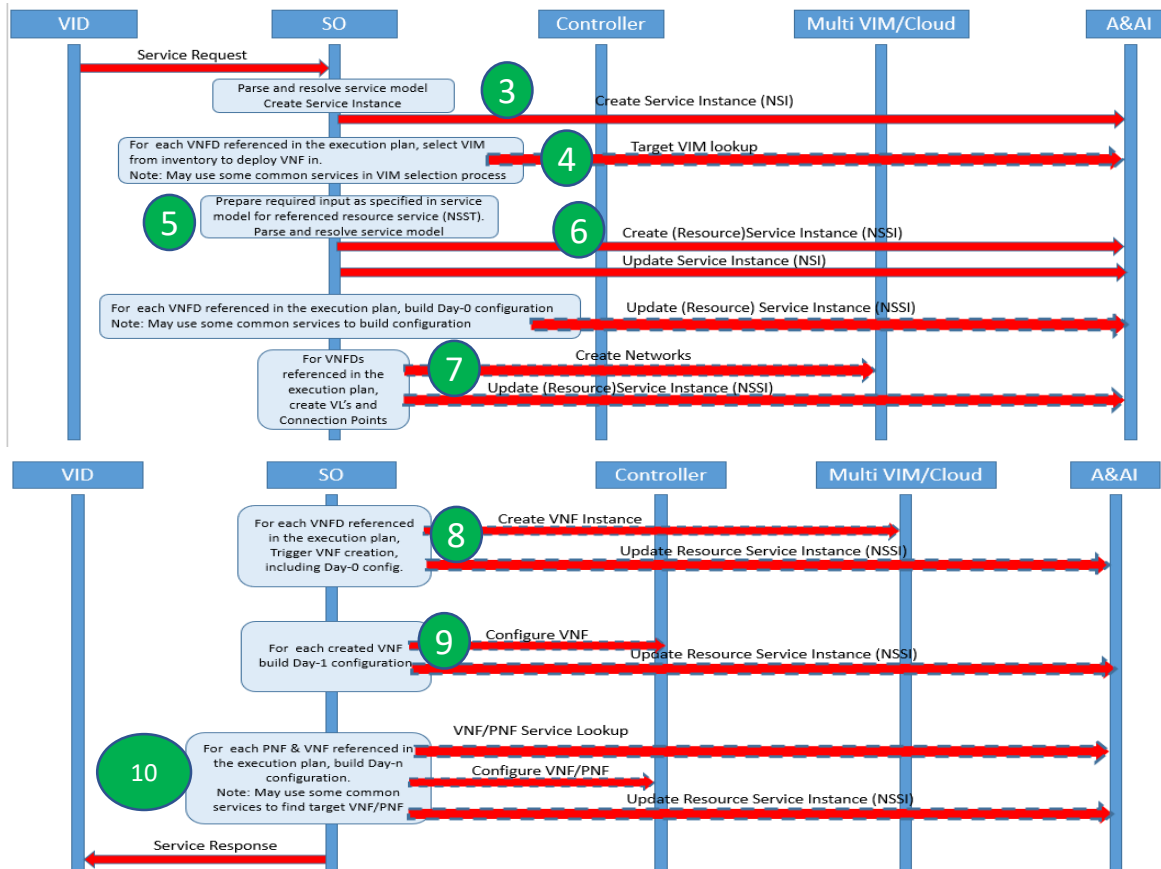

## Run Time

3. Create E2E service instance
4. Determine VNF placement
5. Build required input for lower level service
6. Create resource service instance
7. Create networks
8. Instantiate VNF(s), applying Day-0 configuration
9. Configure instantiate VNF(s) with Day-1 configuration
10. Configure dependent PNF(s) &/ VNF(s) with Day-1 configuration

# NETWORK SLICING in R7 Guilin

R7 Network Slicing is looking to provide: (1) a full E2E Slicing solution involving RAN and Transport NSSMF, and connecting to external Core NSSMF. (2) KPI monitoring and Closed Loop Control (3) Intelligent Slicing (4) Standardized interfaces (5) Model enhancements, AAI schema updates 1:1 mapping between NSI and NSSI

<https://wiki.onap.org/pages/viewpage.action?pageId=38119661>

ENHANCEMENTS	DESCRIPTION
SDC	Enhance CST, NST, design of RAN, Transport NSSTs, KPI monitoring
UUI	Support of CSMF, NSMF, KPI monitoring, Time base service activation
EXT API	Support of standard interfaces for CSMF, NSMF and NSSMF
SO	NSSMF RAN/Transport subnets. Interface standardization, External Core NSSMF, CLC
OOF	NSI selection, NSSI selection, resource reallocation in RAN transport subnets, PM data
DCAE	Data lake, KPI data. uS KPI, Intelligent Slicing, VES enhance, Store AF data
Policy	Control loop enhancement, Config. Policies for OOF, SO, DCAE
SDN-C	NSSMF functionality for RAN & Transport, CLC functionality.
CDS	API mapping on SB interfaces
A&AI	Schema updates for network slicing, net modes for NSI, NSSI, RAN & transport slice inventory
C & P Service	RAN configuration data (cell level initial and network slicing related)

U/C DESCRIPTION

Wiki

R7 Guilin CANDIDATE ENHANCEMENTS

# R7 Guilin General PNF Support U/C SUMMARY

5G USE CASE	DESCRIPTION	Req vs U/C	5G Specific
<b>PNF PRE-ONBOARDING &amp; ONBOARDING</b>	PNF Package delivery, Pre-onboarding and PNF Onboarding via SDC.	Requirements	General
<b>PNF PLUG AND PLAY</b>	PNF PnP enhancements, R3 Carry-overs, PRH (PNF Registration Handler) enhancements	E2E Use Case	General
<b>PNF S/W UPGRADE</b>	PNF Software upgrade to update the software on a PNF. Use of Ansible/NetConf direct to PNF.	Requirements	General
<b>CMPv2</b>	Certificate Management Protocol (Will be presented in its own Lecture at the Virtual Face to Face)	Requirements	General

# PNF PRE-ONBOARDING/ONBOARDING U/C OVERVIEW

**1 PNF Package Delivery:** Vendor creates & delivers PNF Package with PNF artifacts

**2 PNF Pre-Onboarding:** VNF-SDK (⚠️) to (create) PNF Onboarding Package & *validates* of PNF onboarding package

**3 PNF Onboarding package:** Package loaded

**4 SDC: NF OB**  
Package > SDC catalog

**5 ONAP RT Components:**  
Ingest and use CSAR package

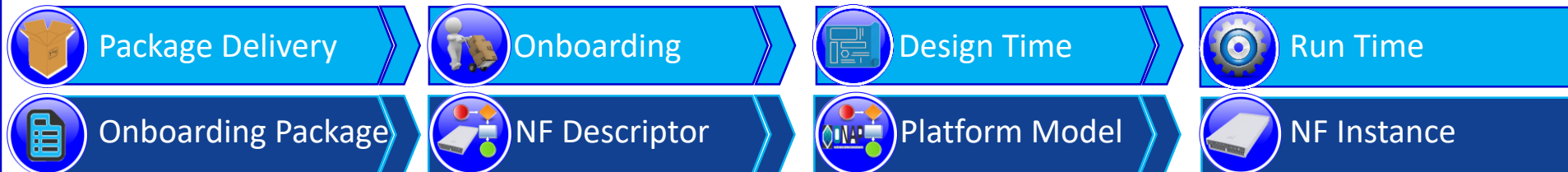
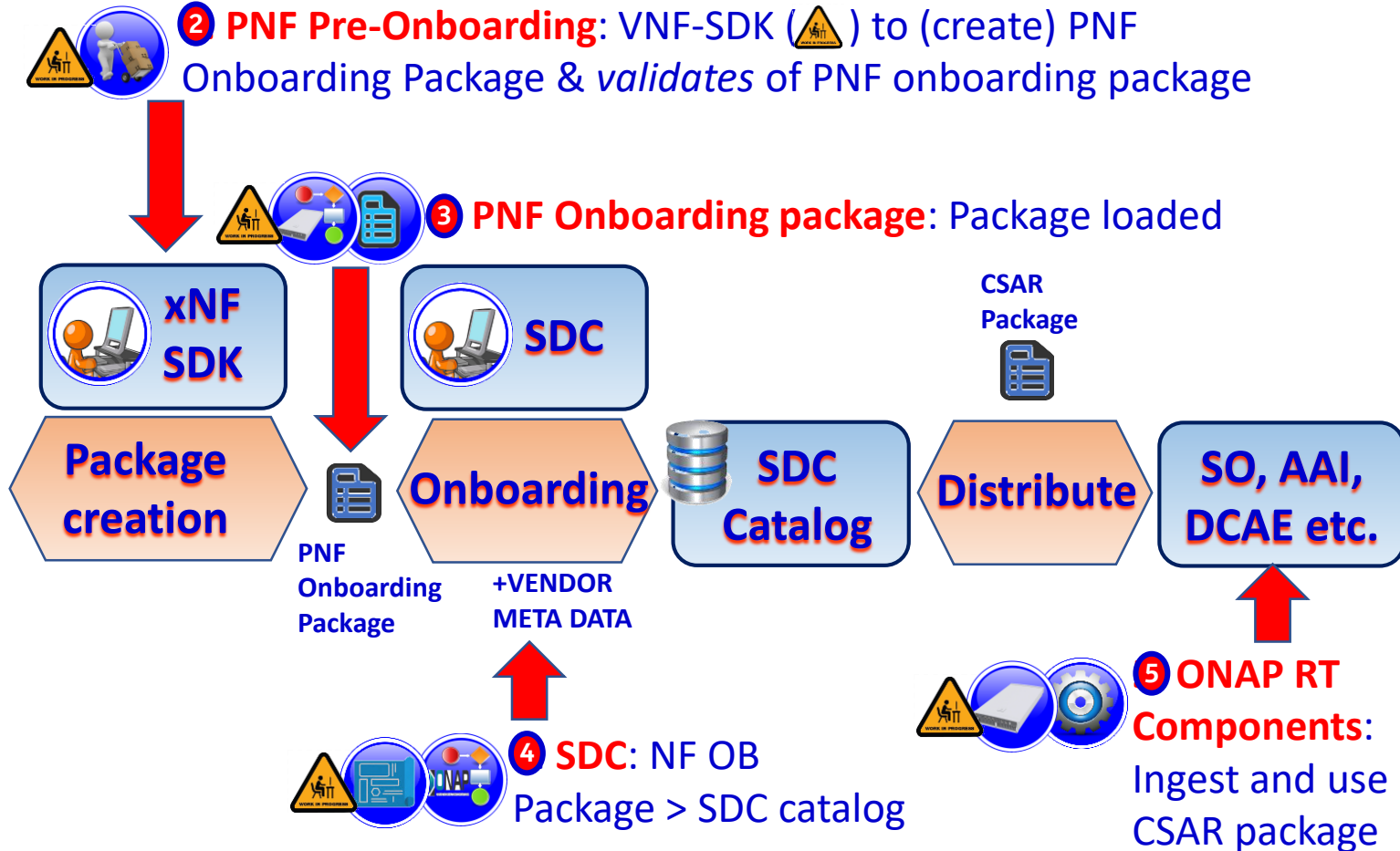
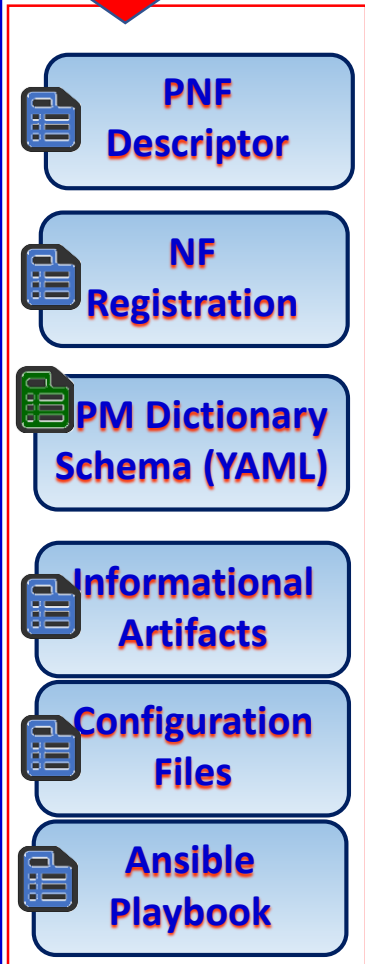



# PNF PRE-ONBOARDING – Business Driver

**EXECUTIVE SUMMARY** - This requirement enhances the PNF Pre-onboarding use case. This requirement introduces package security Option2 improvements on Signature per artifact on the Vendor delivered package as defined in ETSI NFV SOL004 v2.7.1. The validation of onboarded PM dictionary data based on schema information will be done. (What is added from existing functionality)?

**BUSINESS IMPACT** - The enhancement to Onboarding & Pre-onboarding is a critical business function because they are vital to design-time operation to properly onboard vendor packages.

**BUSINESS MARKETS** - This project applies to any domain (wireless, transport, optical, and wireline) that ONAP may manage.

**FUNDING/FINANCIAL IMPACTS** - The PNF Onboarding & Pre-onboarding use case has Operating Expense (OPEX) savings for operators because of the ability to saving time and expenses during installation and commissioning of PNF resources.

**ORGANIZATION MGMT, SALES STRATEGIES** - There is no additional organizational management or sales strategies for this use case outside of a service providers "normal" ONAP deployment and its attendant organizational resources from a service provider.

ETSI GS NFV-SOL 004 V2.7.1 (2019-12)



## Network Functions Virtualisation (NFV) Release 2; Protocols and Data Models; VNF Package and PNFD Archive specification

### 5.2 VNF package manifest and certificate files

In option 1 (see clause 5.1) the manifest file provides the VNF package integrity and authenticity assurance. In this option the manifest contains the digests (hashes) for each individual file locally stored within the VNF package or referenced from it. Each file related entry of the manifest file includes the path or URI of the individual file, the hash algorithm and the generated digest. A consumer of the VNF package shall verify the digests in the manifest file by computing the actual digests and comparing them with the digests listed in the manifest file.

In option1 the VNF package authenticity is ensured by signing the manifest file with the VNF provider private key. The digital signature is stored in the manifest file itself (see clause 5.3). The VNF provider shall include an X.509 certificate [8] in the VNF Package. The certificate shall be either placed in a certificate file with extension .cert or, if the chosen signature format allows it, the certificate may be included in the signature container itself. The certificate provides the VNF provider public key.

In option 2 (see clause 5.1), the VNF package authenticity and integrity is ensured by signing the CSAR file with the VNF provider private key (option 2 in clause 5.1). The digital signature is stored in a separate file. The VNF provider shall also include an X.509 certificate. The certificate may be included in the signature itself if the signature format allows it or in a separate file. The signature and certificate files shall be siblings of the CSAR file, i.e. placed in the same folder in the parent archive. The signature file shall have an extension .cms and the same name as the CSAR file. Naming conventions for the certificate file are specified in clause 4.3.6.

In this alternative (option 2 in clause 5.1) it is not required to include digests (hashes) per each individual file or artefact in the manifest file. A consumer of the VNF package can verify the signature of the complete CSAR package with the VNF provider public key.

Table 5.2-1 summarizes the characteristics of the two possible options for integrity assurance.

Table 5.2-1: Options for VNF Package integrity assurance: summary of characteristics

Options	Digest per artifact	Signature per artefact	Support external artifacts	Signature as part of the manifest file	External Signature file for the whole CSAR	Certificate may be part of the signature	Certificate may be in a separate file
Option 1	Yes	Yes (mandatory)	Yes	Yes	No	Yes	Yes
Option 2	No	Yes (mandatory)	No	Yes	Yes	Yes	Yes

The X.509 certificate may contain one single signing certificate or a complete certificate chain. The root certificate that may be present in this X.509 certificate file shall not be used for validation purposes. Only trusted root certificate pre-installed in NFVO shall be used for validation (see clause 5.1).

# PNF PRE-ONBOARDING/ONBOARDING in R7 Guilin

This Use Case will introduce the support for PNF pre-onboarding (PNF Package, PNF descriptor support) and PNF onboarding (SDC, Design Time, PNF-SDK).  
PNF Package delivery by vendor (during Pre-onboarding activities) and PNF Onboarding via SDC in Dublin.

<https://wiki.onap.org/pages/viewpage.action?pageId=45303641>

R7 CANDIDATE ENHANCEMENTS	IMPACT
VNF-SDK (PNF-SDK)	<b>ETSI SOL004 alignment:</b> <ul style="list-style-type: none"><li>- Package Validation enhancements notable Package security (option 2 security on entire package)</li><li>- Signatures Hashchecks per artifact (applicable for both Option 1 &amp; 2) – in R4/R5/R6 signature Hashcheck may exist for option 1.</li><li>- License Model Check (not applicable for PNF, only for VNF #@#).</li></ul>



# PNF PLUG AND PLAY U/C Overview

Design Time

①



## PNF Modeling

Resources Definition/Services Definition  
SDC: PNF (physical element) Modeling  
Distribution of types

②



## PNF Instance Declaration

PNF Infrastructure Service Declaration  
First part of PNF instantiation  
PNF A&AI Entry created

⑮ ⑯ ⑰ ⑱ ⑲ ⑳ ㉑ ㉒



③



## PNF Boot-strapping

PNF Powers up and Boot-straps  
PNF performs a “Plug and Play” procedure  
Equipment vendor proprietary steps

④



## PNF Contacts ONAP

PNF connects to ONAP via a Registration Event  
PNF Registration Handler (PRH) processes the event

㉓ ㉔ ㉕ ㉖ ㉗ ㉘ ㉙ ㉚

⑤



## PNF Activation

Connection points configured  
Second part of PNF service instantiation  
PNF configured and ready to provide service

㉛ ㉜ ㉝ ㉞ ㉟ ㊱ ㊲ ㊳ ㊴

Run-Time (Instances)

# PNF PLUG AND PLAY – Business Driver

**EXECUTIVE SUMMARY** - This requirement will augment the work-flow to building block management within SO for Plug and Play operation. The continues the work started in R6. The description of the "base" work which will be enhanced is shown in the wiki: [PNF PLUG and PLAY in R6 Frankfurt](#)

**BUSINESS IMPACT** - The enhancement to Plug and Play operation in ONAP is a critical business function because they enhance installation and commissioning activities.

**BUSINESS MARKETS** - This project applies to any domain (wireless, transport, optical, and wireline) that ONAP may manage.

**FUNDING/FINANCIAL IMPACTS** - The plug and play project has Operating Expense (OPEX) savings for operators because of the ability to saving time and expenses during installation and commissioning and contributes towards ZTM (Zero touch management).

**ORGANIZATION MGMT, SALES STRATEGIES** - There is no additional organizational management or sales strategies for this use case outside of a service providers "normal" ONAP deployment and its attendant organizational resources from a service provider.

## Proposed building blocks

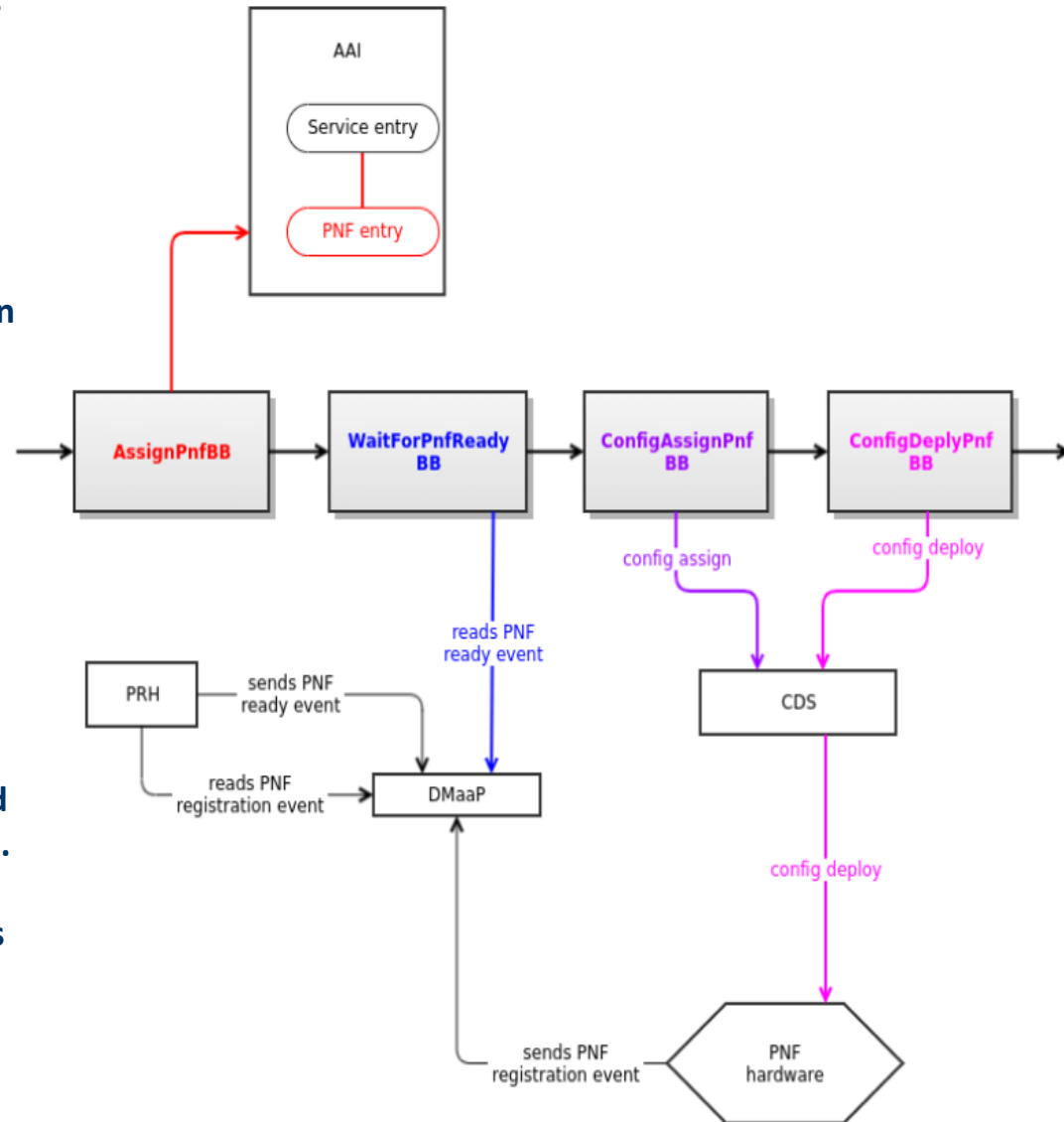

# PNF PLUG AND PLAY for R7 Guilin

This Use Case will continue PNF Plug and Play development started in R3 Casablanca. Functionality that was started but not completed, and introduce some enhancements to improve Plug and Play operation.

<https://wiki.onap.org/pages/viewpage.action?pageId=40206485>

## R7 CANDIDATE ENHANCEMENTS

### Description

AAF / CMPv2

Security enrollment enhancements integration with DCAE. Code merging with OOM. Using CMPv2. R6 REQ-140 (see later slides)

SO

Service configuration to PNF by controller (**Step 37**) NetConf.  
Impact to inventory (A&AI)  
BB based W/F connected to Configuration Steps to integrate & complete.

Licensing Management

Enhancements for requesting License Key File (LKF) & Licenses from License Service (message exchange)

# PNF S/W UPGRADE in R7 Guilin

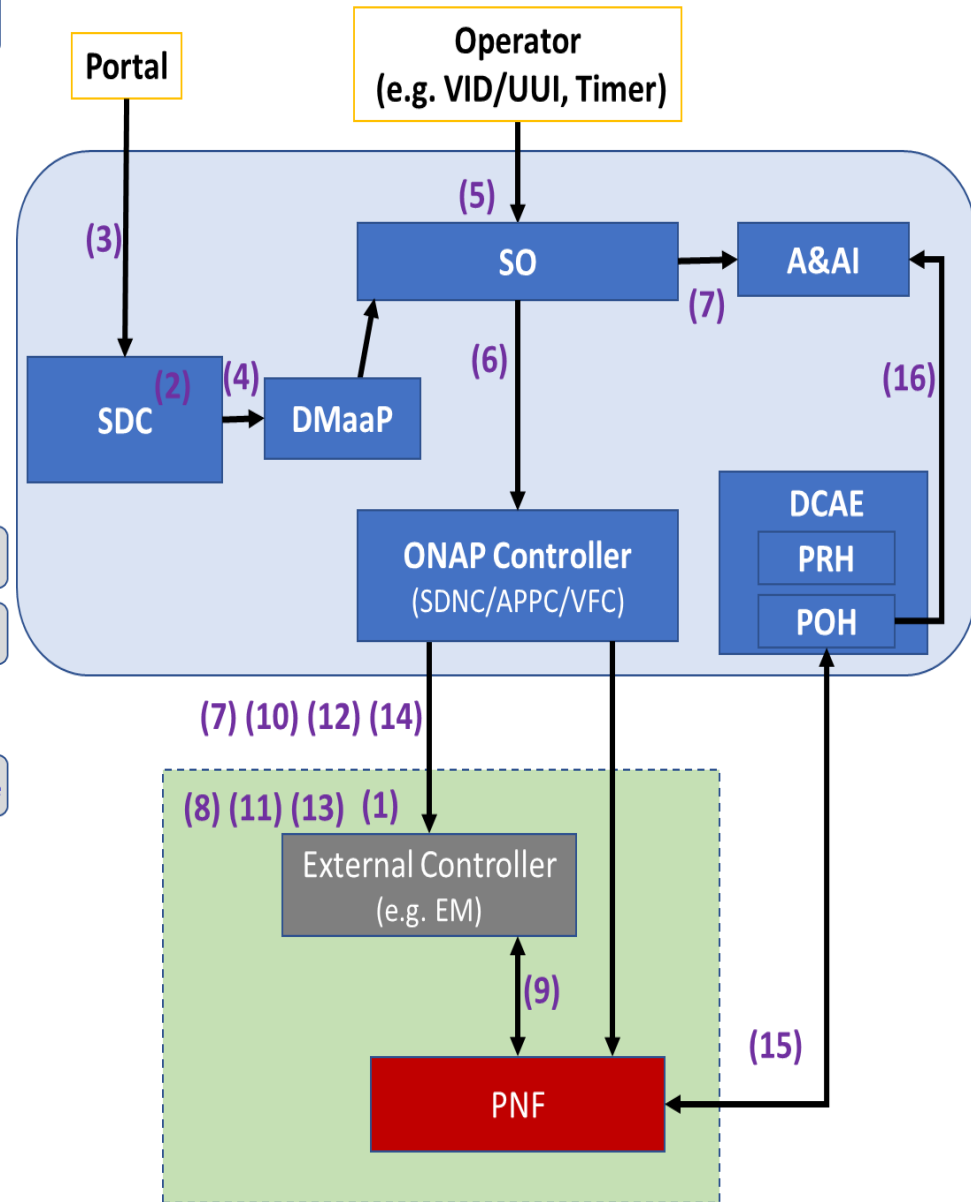
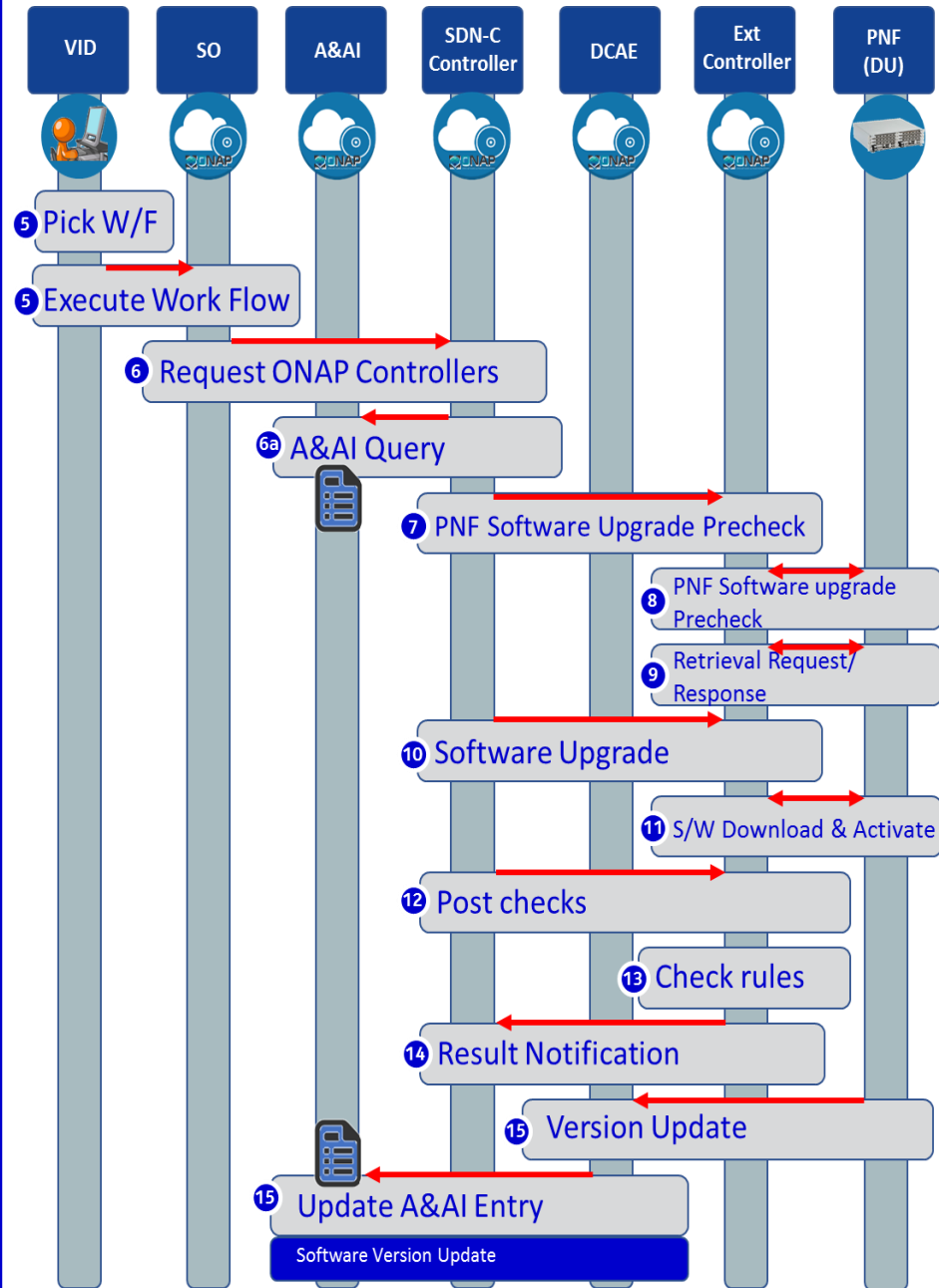

# PNF S/W UPGRADE for R7 Guilin

PNF Software upgrade is one aspect of Software Management. The purpose is to modify the software running on the PNF. This could be used to update the PNF software to a newer or older version of software.

<https://wiki.onap.org/pages/viewpage.action?pageId=40206485>

## R7 CANDIDATE ENHANCEMENTS

## IMPACT

Enable service level LCM operations

- PNF software upgrade with updated service template
- PNF schema update with updated service template
- Service template update with multiple resource instances

# CERTIFICATE MANAGEMENT PROTOCOL (CMP)

**EXECUTIVE SUMMARY** - This requirement improves ONAP Security with CMPv2. CMP is used by multiple operations including Plug and Play, and NetConf operation. In R6 CMPv2 Certificate Service and basic development was implemented. Integration with server & client to the certificate service will be completed. There are also two ONAP bordering clients to integrate with the certificate service with interfaces to (SDN-C = Done) and DCAE. DCAE interoperation with CMPv2. REQ-140

**BUSINESS IMPACT** - The enhancement to CMPv2 operation will improve security management within ONAP and affects multiple ONAP functions and use cases, including Plug and Play (PNF registration) and NetConf. As with all security functionality within ONAP, Security is a fundamental aspect of FCAPS, being the "S" for security management.

**BUSINESS MARKETS** - This project applies to any domain (wireless, transport, optical, and wireline) that ONAP may manage.

**FUNDING/FINANCIAL IMPACTS** - Potential OPEX savings with enhanced security to prevent breaches and prevent security compromises.

**ORGANIZATION MGMT, SALES STRATEGIES** - There is no additional organizational management or sales strategies for this use case outside of a service providers "normal" ONAP deployment and its attendant organizational resources from a service provider.

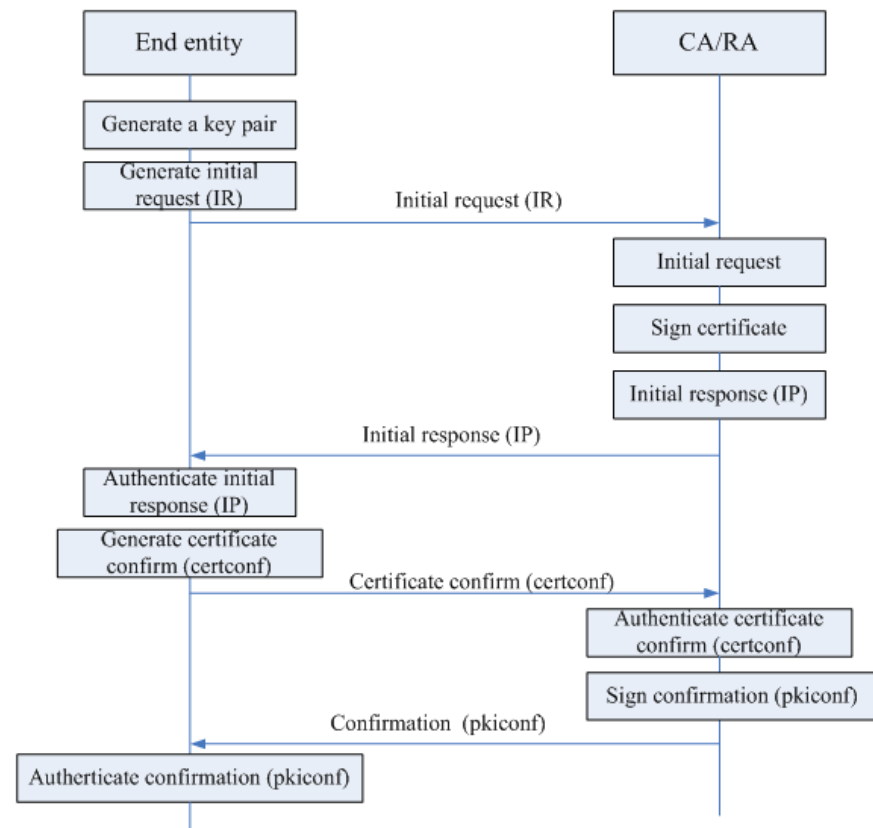
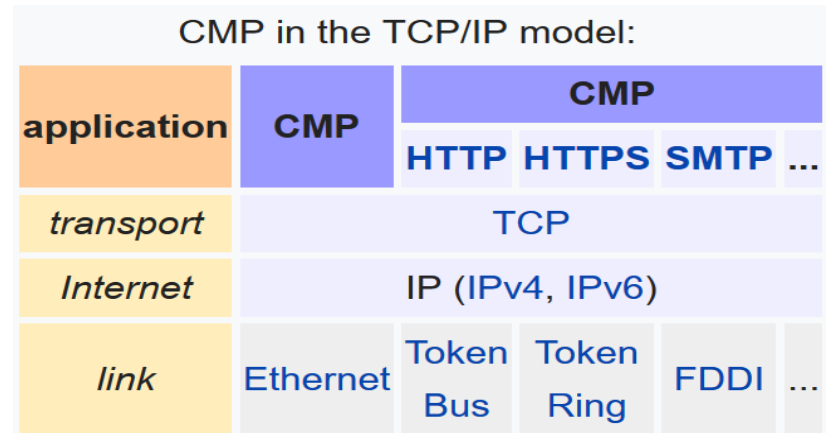

# CMP v2 for R7 Guilin

The Certificate Management Protocol (CMP) is an Internet protocol used for obtaining X.509 digital certificates in a public key infrastructure (PKI). It is described in RFC 4210 and is one of two protocols so far to use the Certificate Request Message Format (CRMF), described in RFC 4211, with the other protocol being Certificate Management over CMS (CMC), described in RFC 5273. An obsolete version of CMP is described in RFC 2510, the respective CRMF version in RFC 2511. CMP messages are encoded in ASN.1, using the DER method and usually transported over HTTP. CMP (Certificate Management Protocol) Server & Client (completed in R6)

<https://wiki.onap.org/pages/viewpage.action?pageId=40206485>

R7 CANDIDATE ENHANCEMENTS	IMPACT
CMP v2	Integration of bordering ONAP components – DCAE Enhancements in certificate in CMPv2: (a) DCAE team requests output artifacts should be configurable (P12, PEM) (b) Certificate renewal (Best effort)