

Use Cases for R7 Guilin



- Overview of R7 ONAP Use Cases
- ORAN Plugfest (Sept 28 – Oct 2)

ONAP 5G Use Case Team (Presenters / Ben Cheung, Vimal Begwani)

June 23, 2020 version 2

R7 Guilin 5G USE CASE SUMMARY

5G USE CASE	DESCRIPTION	Req vs U/C	5G Specific
BULK PM – PM control	PM data collection control provides a dynamic and efficient way to configure performance measurement collection on a selected subset of xNFs and complements the existing PM data collection and processing capabilities.	Requirements	General
OOF - SON PCI (5G)	Optimization and SON functions for 5G RAN. Self-optimization, Self-Healing, Self-configuration.	Requirements	5G
5G SERVICE MODELING & DEFINITION (5G)	Defining and modeling a 5G Service (in Design Time) and associated Modeling (Platform Info & Data Model).	Requirements	5G
CONFIGURATION & PERSISTENCY SERVICE	Configuration Persistency Service using internal Database for storing Network related data for use in LCM, OSS, Network, Operational applications.	Requirements	General
xNF LICENSING MANAGEMENT	Continue xNF License Management UC analysis for xNF onboarding, PNF introduction/ONAP PnP and VNF instantiation. Bring in new UCs like usage monitoring for the purpose of invoicing.	Requirements	General
ONAP/3GPP & ORAN Alignment	Standards Defined Notifications over VES Introducing the capability to receive, validate and process standards defined notifications encapsulated in VES events in ONAP. Also with A1 Adaptor extension.	Requirements	General
ONAP/ORAN Alignment - A1 adaptor	A1 adaptor: Enhancing the A1 adaptor/interface capabilities in ONAP to manage A1 Policies, support multiple A1 targets in the RAN and multi-version A1 interface for different A1 targets, introduce secure TLS communication.	Requirements	General
E2E NETWORK SLICING (5G Use Case)	Network Slicing defines Slices for 5G RAN systems. Network Slicing is a long-lead (multi-release) development. (will be presented in its own lecture at the Virtual Face to Face)	E2E Use Case	5G

R7 Guilin PNF Support U/C SUMMARY

5G USE CASE	DESCRIPTION	Req vs U/C
PNF PRE-ONBOARDING & ONBOARDING	PNF Package delivery, Pre-onboarding and PNF Onboarding via SDC.	Requirements
PNF PLUG AND PLAY	PNF PnP handles the PNF discovery and registration by ONAP during installation & commissioning. PRH (PNF Registration Handler) enhancements	E2E Use Case
xNF S/W UPGRADE	PNF Software upgrade to update the software on a PNF. Use of Ansible/NetConf direct to PNF.	Requirements
PNF - CMPv2	Certificate Management Protocol (Will be presented in its own Lecture at the Virtual Face to Face)	Requirements
ETSI Alignment		Requirements
MDONS		Requirements

R7 Guilin Use Cases

Guilin (R7) - Use Cases

Created by Alla Goldner, last modified by Benjamin Cheung just a moment ago

5G Use Cases & Requirements in R7 (GuiLin)

The "directory" of 5G Use Case Wiki are located here: [5G Use Cases in R7 Guilin](#)

USE CASE / REQUIREMENT	DESCRIPTION	WIKI
OOFS ON (PCI)	Optimization and SON functions for 5G RAN which provide for self-optimization, self-healing and self-configuration	R7 OOF SON Use Case
5G SERVICE MODELING & DEFINITION	Defining and modeling a 5G Service (in Design Time) and the associated Modeling (Platform information & data model). This is driven by 3GPP TS28.540 and TS28.541, the 5G NRM.	R7 5G Service Modeling
ONAP/3GPP & O-RAN Alignment: Standards Defined Notifications over VES	The capability to receive, validate and process standards defined notifications encapsulated in VES events in ONAP. Modeling: VES 7.1	ONAP/3GPP & O-RAN Alignment-Standards Defined Notifications over VES
ONAP/3GPP & O-RAN Alignment: A1 Adaptor Extension	A1 Adaptor extension for Standards Harmonization. ONAP acting as Non RT-RIC; ONAP sending policies A1 policy.	
5G NRM (CM)	5G Network Resource Model introducing Configuration Management (CM Updates) using RESTful (HTTPS) Interface (instead of NetConf)	5G Network Resource Model (NRM) Configuration in R7
E2E NETWORK SLICING	5G Network Slicing defines slices to be used in 5G RAN systems. Network Slicing is a long-lead multi-release development.	E2E Network Slicing Use Case in R7 Guilin
BULK PM: PM CONTROL	PM Control/"PM Control plane" in ONAP has been introduced in Rel 6 to complete Bulk PM use case enabling configuration of PM jobs/subscriptions on xNFs.	
INTENT BASED NETWORK	The Intent-based Network (IBN) is applied to the configuration and optimization of network functions based on the Intents. The current version of IBN is applied to the opening and closed-loop operation of network slices in the 5G use case.	Intent-Based Network

PNF Use Cases & Requirements in R7 (GuiLin)

The "directory" for the PNF Use Case Wikis are located here: [PNF Use Cases & Requirements in R7 Guilin](#)

USE CASE / REQUIREMENT	DESCRIPTION	WIKI
PNF PLUG AND PLAY	PNF Plug and Play allows for ONAP to support PNF registration and discovery. The DCAE component, PRH (PNF Registration Handler) processes the PNF registration VES event.	R7 PNF Plug and Play PnP

<https://wiki.onap.org/display/DW/Guilin+%28R7%29+-+Use+Cases>



5G Service Creation Use Case

5G SERVICE CREATION & MODELING in R7 Guilin

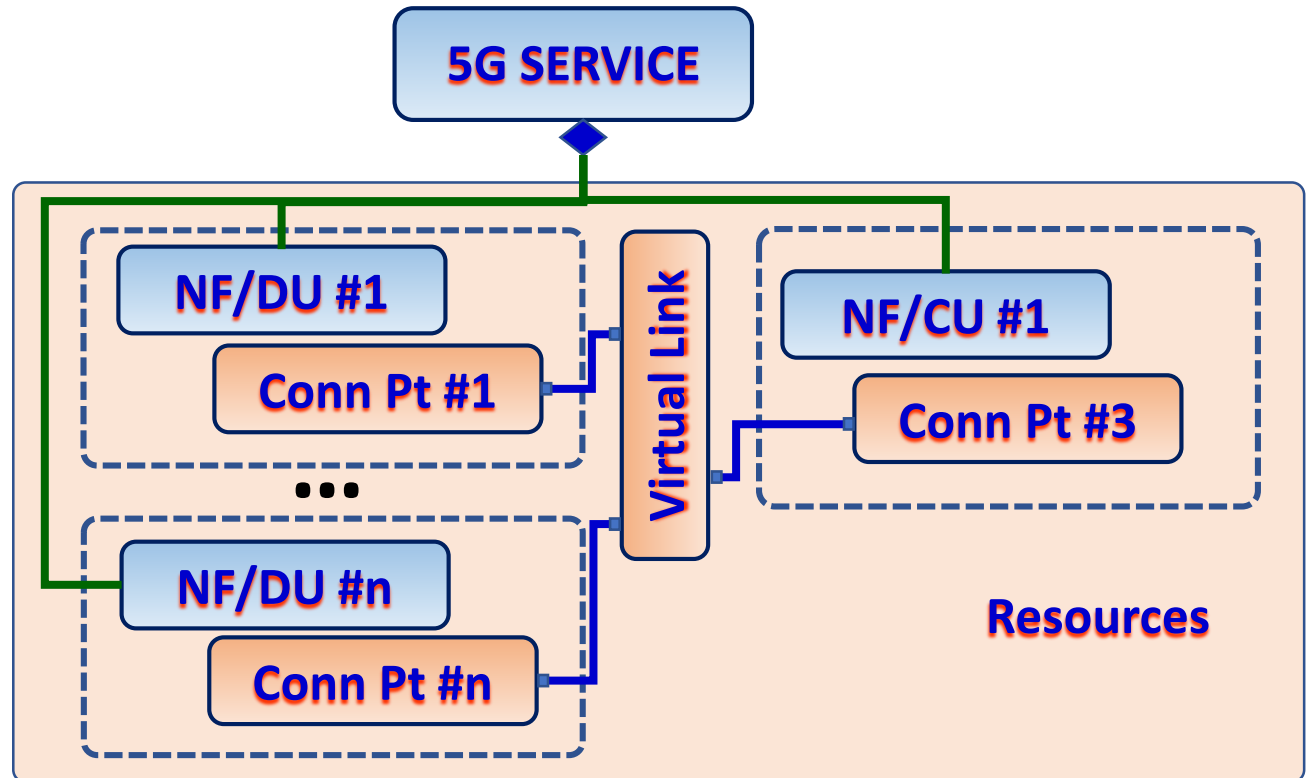
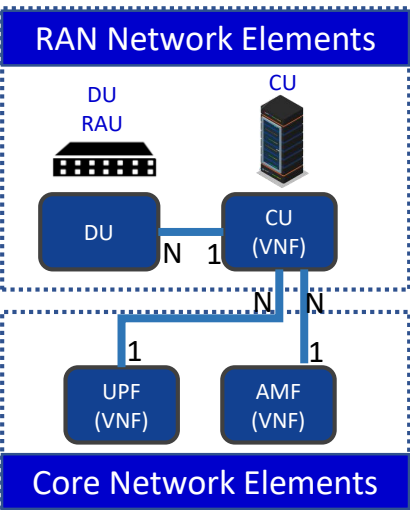
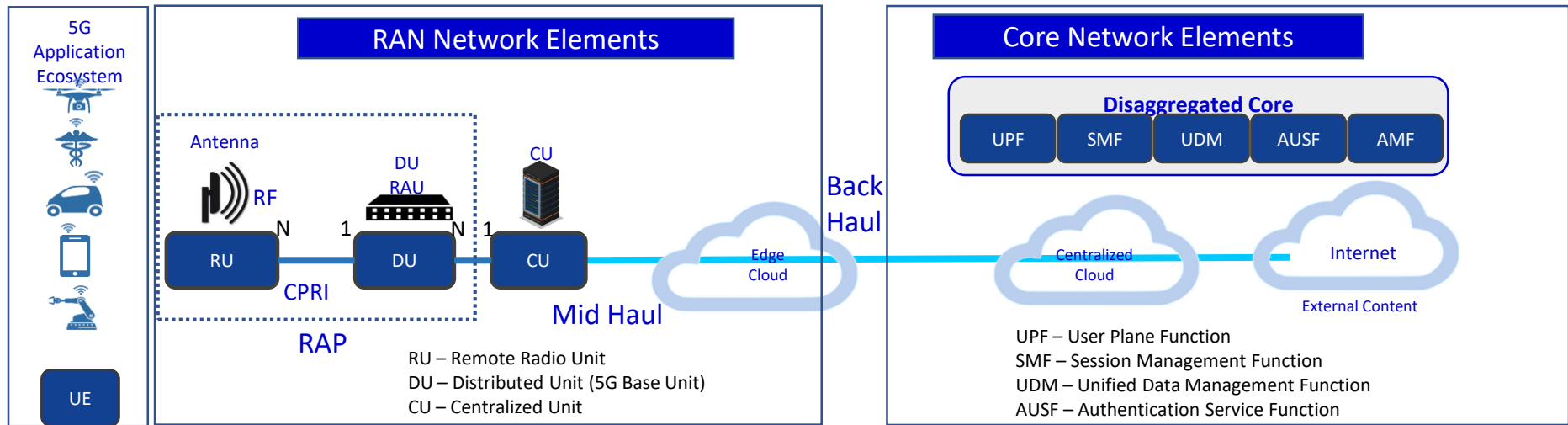

5G SERVICE CREATION & MODELING in R7 Guilin

Vendor #1

Vendor Onboarded CSAR
NRM Artifact



5G NRM

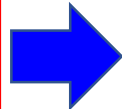

DESIGN TIME



Application Model

+ Domain & Vendor specific

xNF Resource



Service CSAR



RUN TIME



SDN-C (etc.)

U/C μ -Service

C&PS Database



C&PS Record
xNF instance
NRM artifact



PNF#106

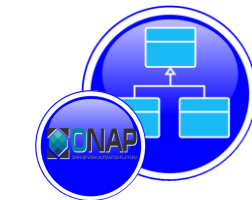

Platform Information Model



StdDef VES

PNF#106

Vendor #2

Vendor Onboarded CSAR
NRM Artifact



5G NRM

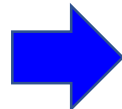



Bulk PM – PM Control Extensions

Bulk PM – PM Control

- PM Control/“PM Control plane” in ONAP has been introduced in Rel 6 to complete Bulk PM use case enabling configuration of PM jobs/subscriptions on xNFs.
- PM consumers can conveniently define PM subscriptions on (sub)network-level, thereby configuring PM on a set (small or large) of xNF instances in a single subscription. Different consumers to manage their own subscriptions, independently of each other

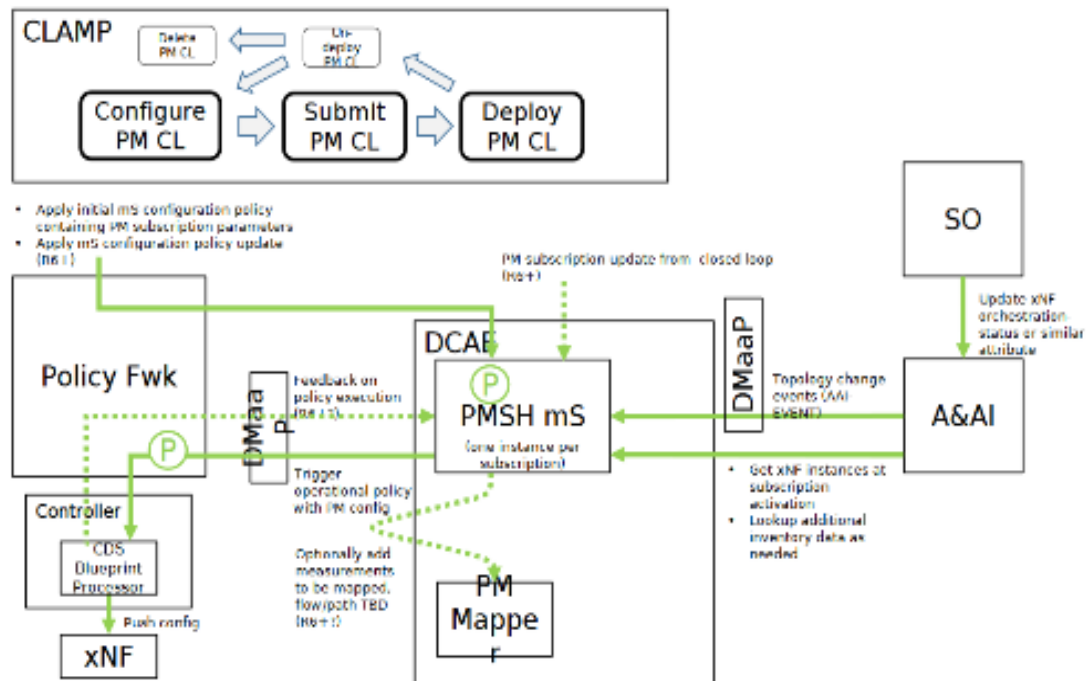
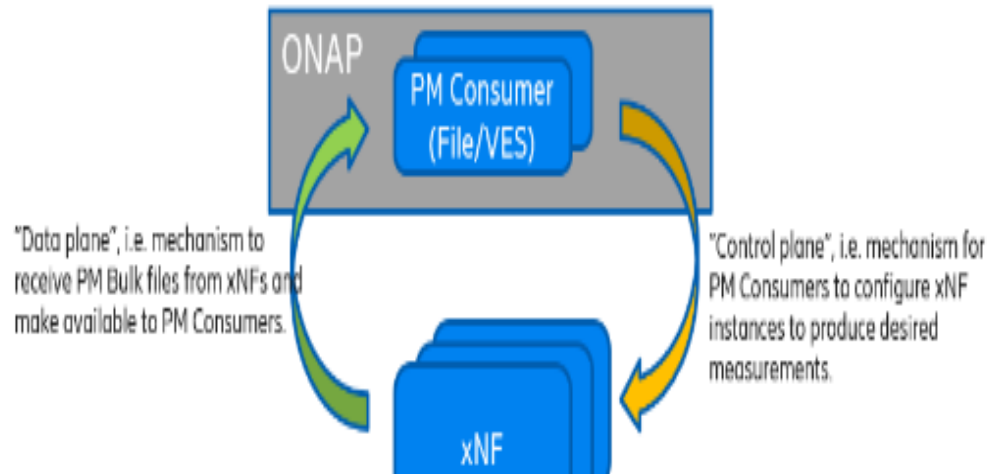

Bulk PM – PM Control for R7 Guilin

PM data collection control provides 5G network operators with a dynamic and more efficient way to configure performance measurement collection on a selected subset of PNFs/VNFs in the network and complements the existing PM data collection and processing capabilities in ONAP/DCAE. An initial version has been delivered in Rel 6 (5G / Bulk PM / PM Control - [REQ-129](#)). Planned enhancements for Rel 7 intend to further increase the capability and the dynamicity of this feature.

Key Contacts: Michela Bevilacqua (Ericsson), Mark Scott (Ericsson)

<https://wiki.onap.org/pages/viewpage.action?pageId=84644982>

R7 CANDIDATE ENHANCEMENTS	DESCRIPTION
DCAE	<ul style="list-style-type: none">Improve usability of PMSH instantiation with CLAMP integration and enhanced Policy support.Support for additional A&AI parameters to allow more flexible filtering.Support dynamic modification of subscriptions.Error handling improvements and logging enhancement to comply with DCAE guidelines.Enable PMSH to support N subscriptions



OOF SON PCI Use Case

5G Self-Organizing Network using OOF in R7 Guilin

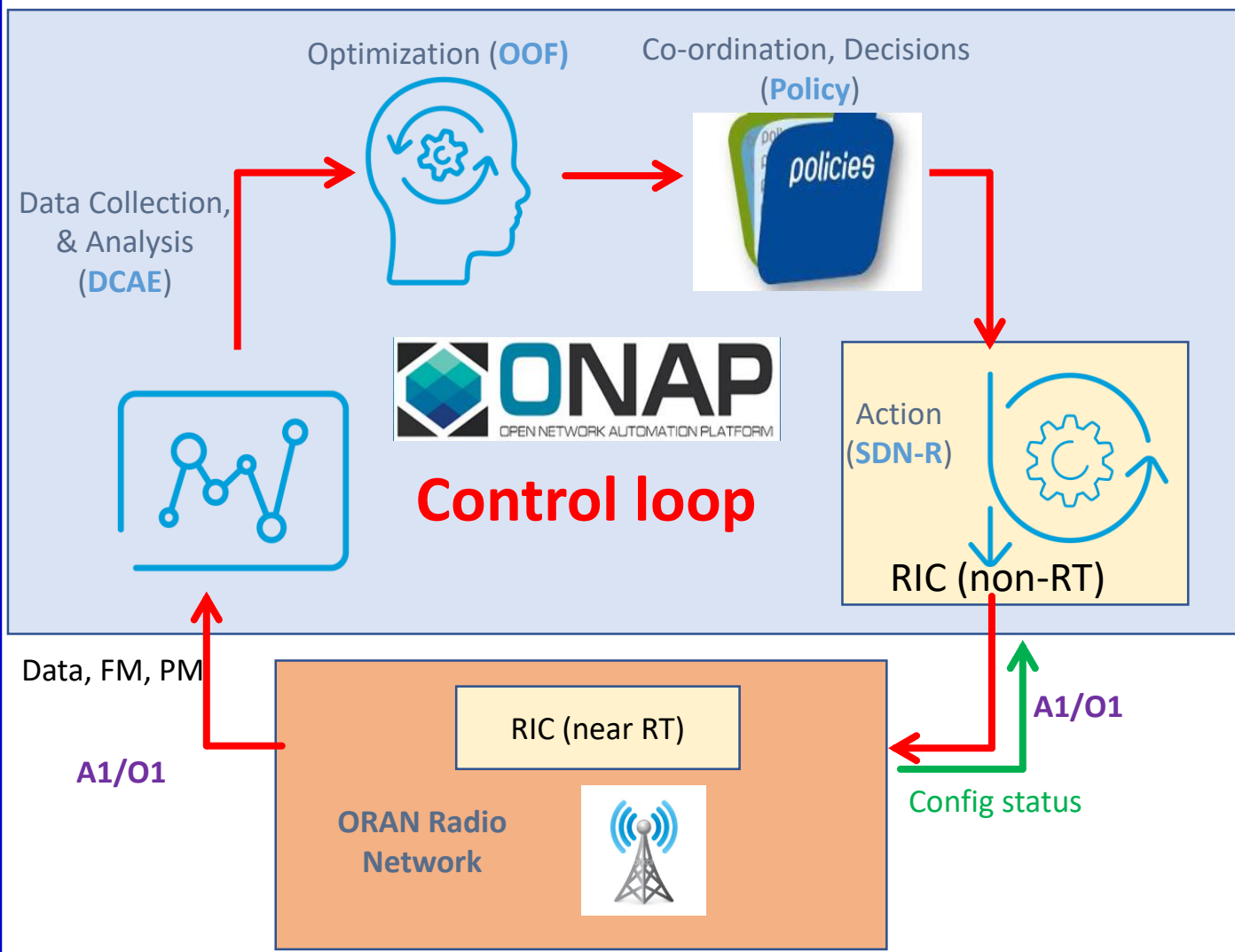

- Companies can use framework to add proprietary SON solutions
- SON is built on 3 concepts: Self-Optimization, Self-Healing, Self-Configuration
- Use Case started R3 Casablanca
- R6 Enhancements:
- CM-Notify handling
- Control Loop Co-ordination (CLC)
- Introduced Adaptive SON functionality
- Checked in RAN-Sim into ONAP repo
- R7 ML Based SON

5G Self-Organizing Network using OOF in R7 Guilin

- **PHYSICAL CELL ID (PCI)** is a 4G/5G integer ID
 - Used for handoff
 - PCI ranges: (LTE: 0-503, 5G: 0-1007)
- **PCI OPTIMIZATION**: solves **PCI collision & PCI confusion**
- **AUTOMATED NEIGHBOR RELATIONS (ANR)** builds & maintains neighbor relation tables in eNodeB and gNodeB
- **OPTIMIZATION** - PCI is re-optimized if neighbor relationship changes

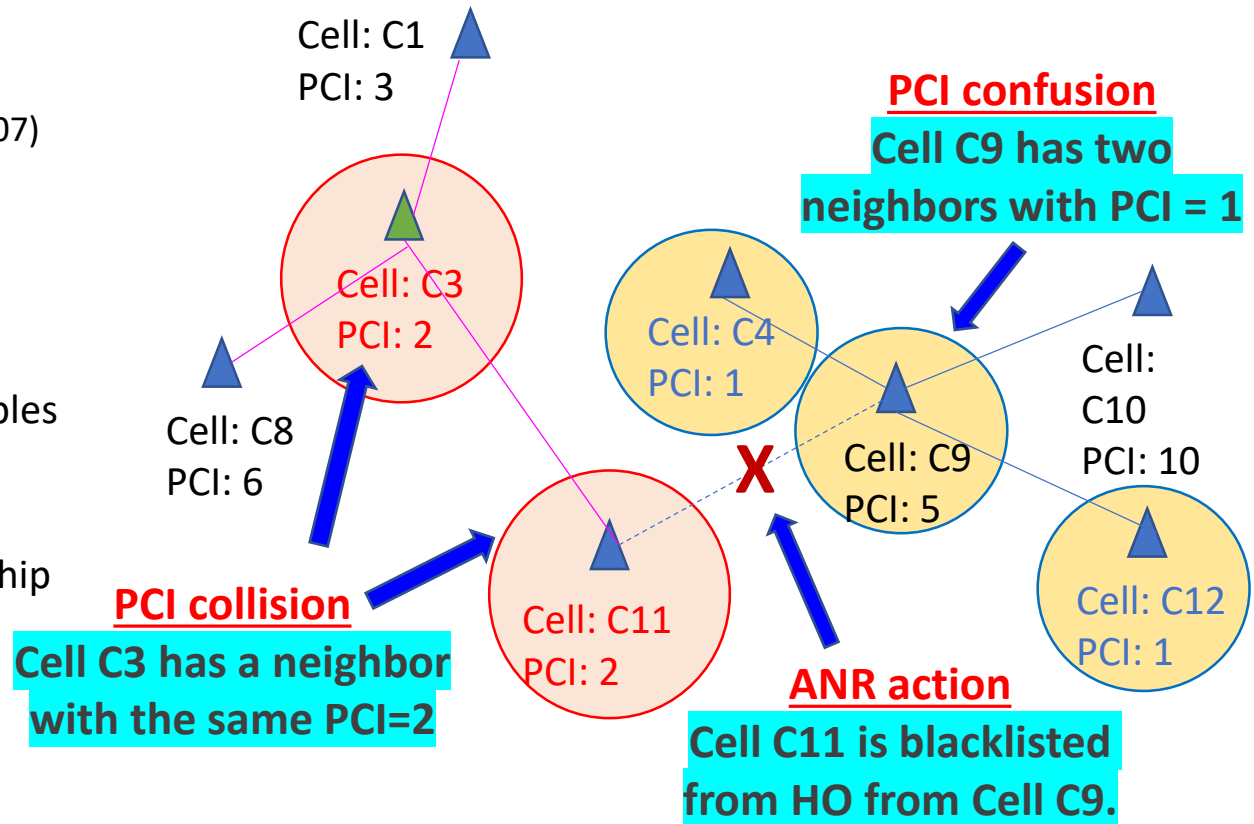

- **GRAPH COLORING PROBLEM** – PCI assignment is akin to a coloring problem to avoid colors of nodes of neighbors

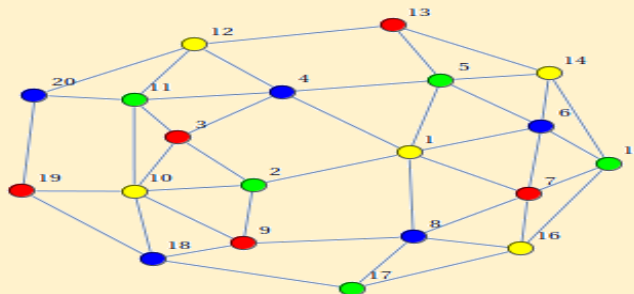

5G Self-Organizing Network (SON) using OOF

- CM as VES msg
- Config DB (RCDB) model based on network yang

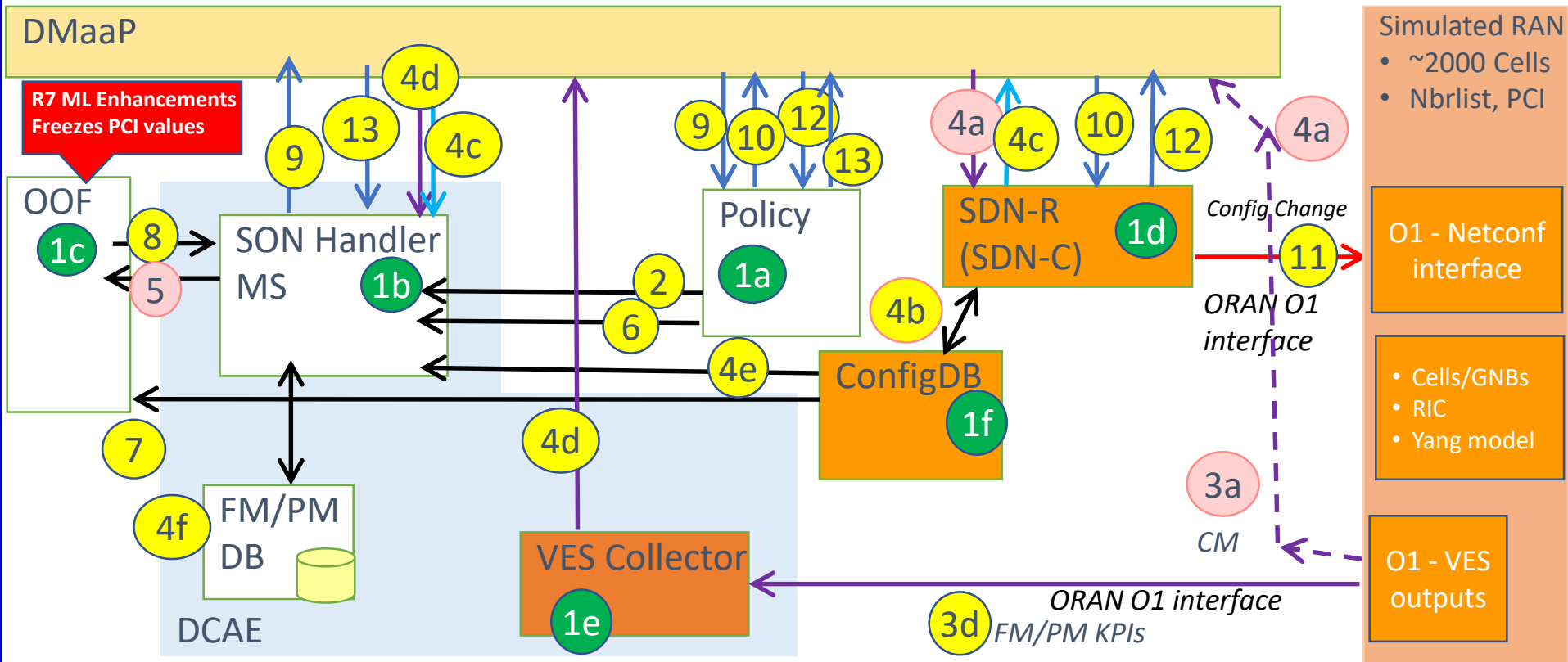

• FM/PM Collector and Database

(n) Interface enhancements

→ REST API → DMaaP Control Loop messages

→ CM-FM-PM messages from RAN → Config updated to RAN (netconf)



LICENSING MANAGEMENT

LICENSING MANAGEMENT in R7 Guilin

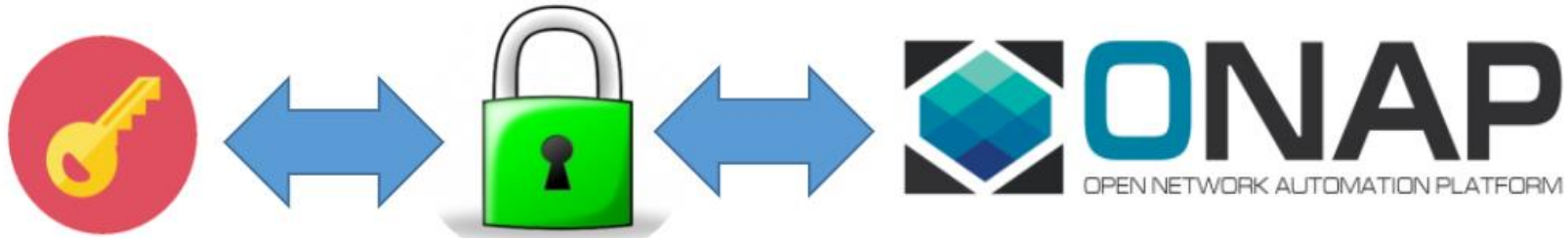

Executive Summary - Continue use case analysis for xNF License Management and derive any requirements to ONAP. The aim is for ONAP to support various types (simple, complex, vendor specific) commercial licensing models and use cases. These will be reflected as multiple, optional solutions for ONAP. The use cases we started with include xNF onboarding, PNF introduction/ONAP PnP, VNF instantiation. Further use cases to be analyzed, e.g. usage monitoring for the purpose of invoicing. Based on agreed use cases review relevant ONAP xNF requirements. Possible SW contributions, e.g. in SDC, as well as enhancement of ONAP architecture sequence diagrams.

Business Impact - xNF License Management is a critical business function. Agreed use cases should allow ONAP to flexibly support commercial licensing models.

Business Markets – The requirement applies to any domain (wireless, transport, optical, wireline) that ONAP will manage. It is not a market specific function.

Funding/Financial Impacts - The use case is fundamental for supporting efficiently business agreements between the operator and the vendor.

LICENSING MANAGEMENT in Design Time

Create a Licensing Model

- CREATE NEW VLM with a license Name, description
 - ADD ENTITLEMENT POOL : name
 - ADD LICENSE KEY GROUP (optional): name and universal type
 - ADD FEATURE GROUP: name, part number, manufacturer reference number, link a entitlement pools, link a license key group.
 - ADD LICENSE AGREEMENT: name, license term, link with one feature group

Create a VSP

- CREATE NEW VSP: name, a **license model**, and category. A VSP can be created from a vendor provided onboarding package or using SDC GUI
- Two xml files are added by SDC under Artifacts folder: vendor-license-model.xml and vf-license-model.xml.
- Modify the VSP, e.g. add additional artifacts (optional step)

Create a Resource

- Create a VNF / PNF from the VSP
- vendor-license-model.xml → Artifacts/Deployment/VENDOR_LICENSE
- vf-license-model.xml → Artifacts/Deployment/VF_LICENSE folder
- Modify the VSP, e.g. add additional artifacts (optional step)

Design a Network Service

- Create a service template
- Add at least one resource (VNF or PNF) into the service template
- Add additional artifacts, e.g. ECP, workflow. (optional step)

Testing

Approve

Distribution

PNF PLUG AND PLAY & Licensing Management

R7 Guilin

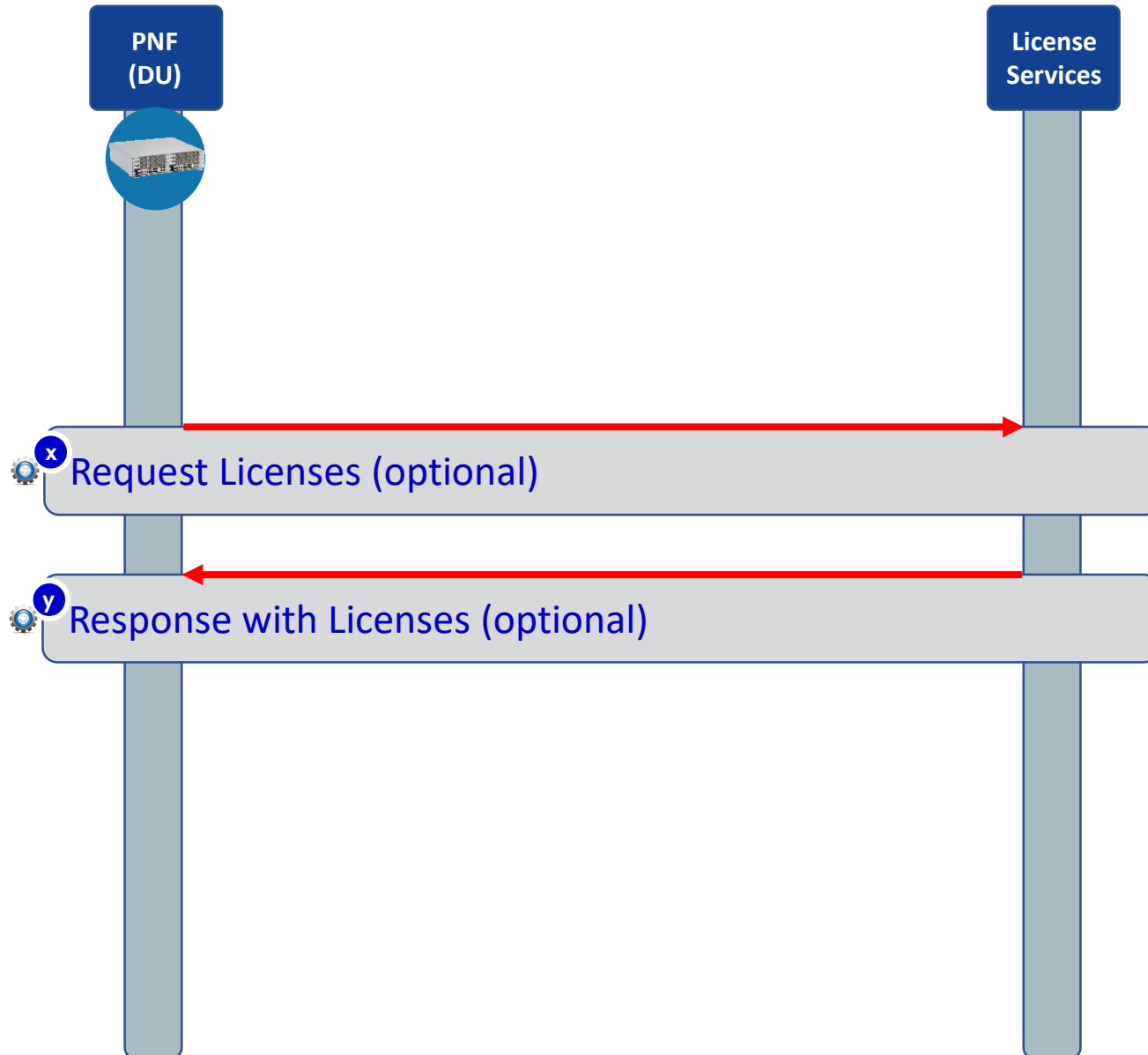



ONAP/3GPP & ORAN Alignment

- Standard Defined VES Event
- A1 Adaptor Extensions

ONAP/3GPP & ORAN Alignment in R7 Guilin

Logical Architecture of O-RAN—ONAP as O-RAN compliant SMO

ONAP is concerned with O1, O2 and A1 interfaces ONLY.

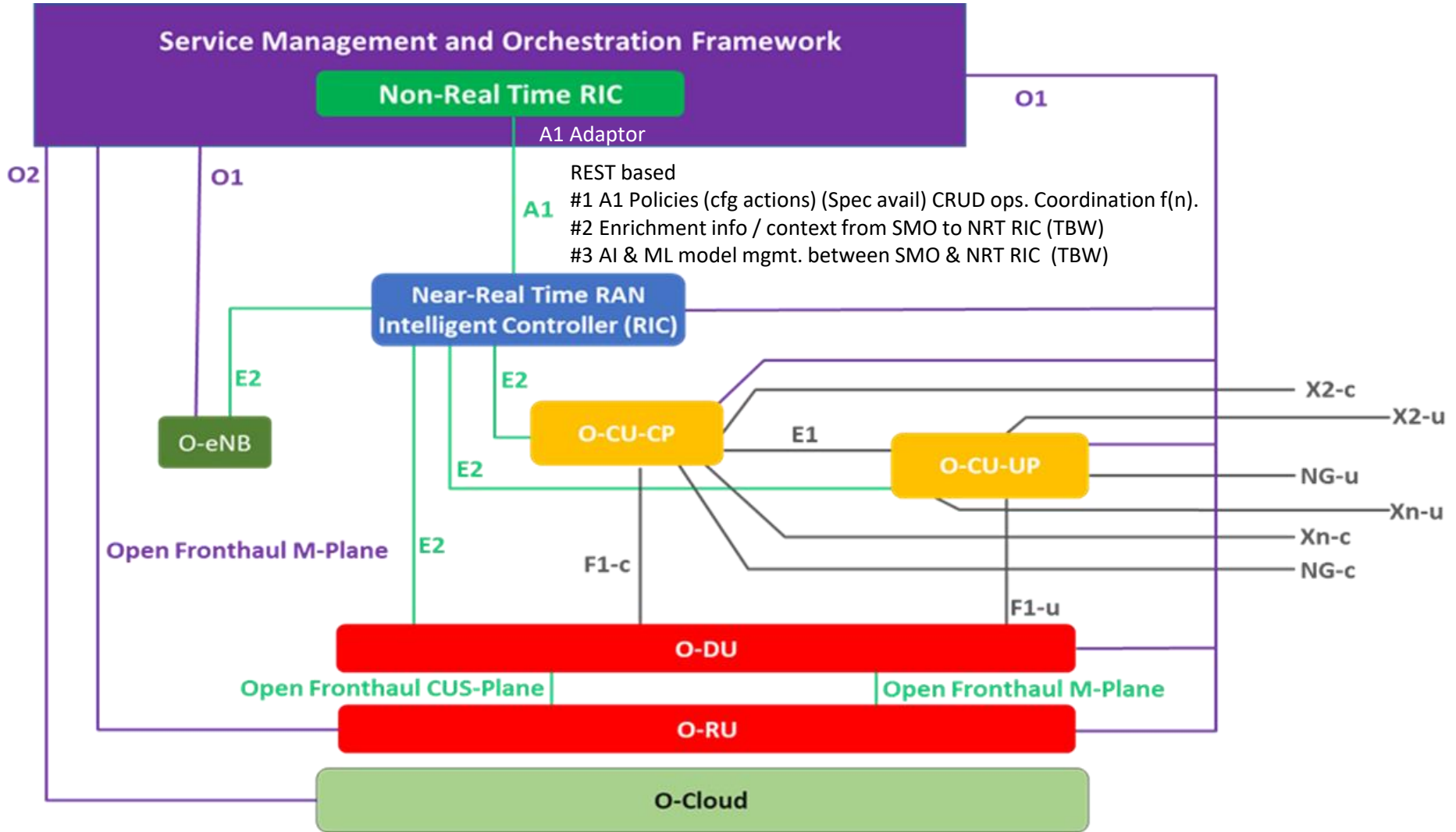

ONAP/3GPP & ORAN Alignment in R7 Guilin

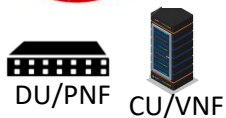

PNF
VNF

VES
Event

Standards Defined
VES Event
for Configuration

The PNF has a parameter update to report. The update originates from the PNF and is reported through a Standards Defined VES event with a configuration NameSpace (3GPP-Provisioning)

1

DCAE VES
Collector



DCAE Inventory

DCAE
Analytics

Standards Defined VES Event is received by the *DCAE VES Collector*. DCAE publishes the VES Event onto the DMaaP Bus.

DMaaP

Configuration NameSpace topic
3GPP-Provisioning

C&PS Update

In R8+: CPS as a stand-alone component, subscribes to the DMaaP Topic and gets the DMaaP event from the DMaaP bus to update the internal database. The VES event has a Configuration namespace topic, 3GPP-Provisioning

Config & Persist
Service



C&PS Database

Run-Time Operational Data
Configuration Info
Exo-Inventory Data
RT Logical & Physical Connections



ONAP/3GPP & ORAN Alignment - A1 Adapter Extension

Executive Summary - This requirement enhances the A1 adapter/interface capabilities provided in Rel 6 as part of 5G / ORAN & 3GPP Standards Harmonization requirement (REQ-38). O-RAN has defined A1 interface specification in the context of the management of 5G RAN elements to provide intent based policies for optimization of the RAN network performance. Planned enhancements for Rel 7 include additional support for managing A1 Policies, multiple A1 targets in the RAN, multi-version support for different A1 targets, and secure TLS communication.

Business Impact - Continuing the convergency between ONAP and ORAN initiated in Rel 6, A1 interface can be used by all service providers and avoid duplicate development effort.

Business Markets -Enhanced A1 capabilities, once developed, will be useable by any service provider deploying and using ONAP.

Funding/Financial Impacts - A1 interface provides a flexible way for the operator to manage wide area RAN network optimization, reducing capex investment needs.

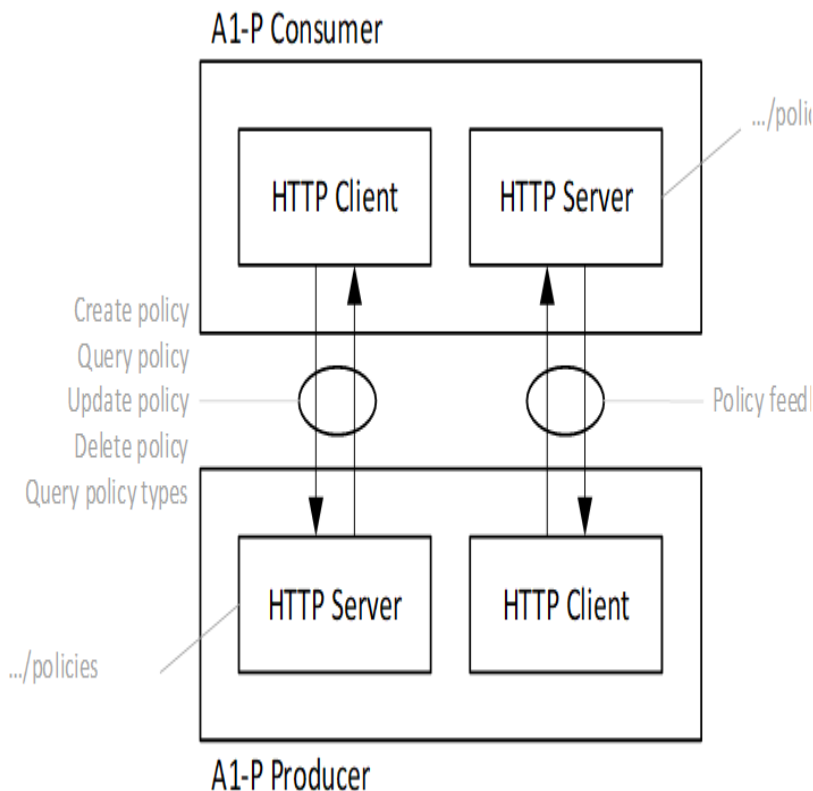



CONFIGURATION & PERSISTENCY SERVICE (C&PS)

CONFIGURATION & PERSISTENCY SERVICE in R7 Guilin

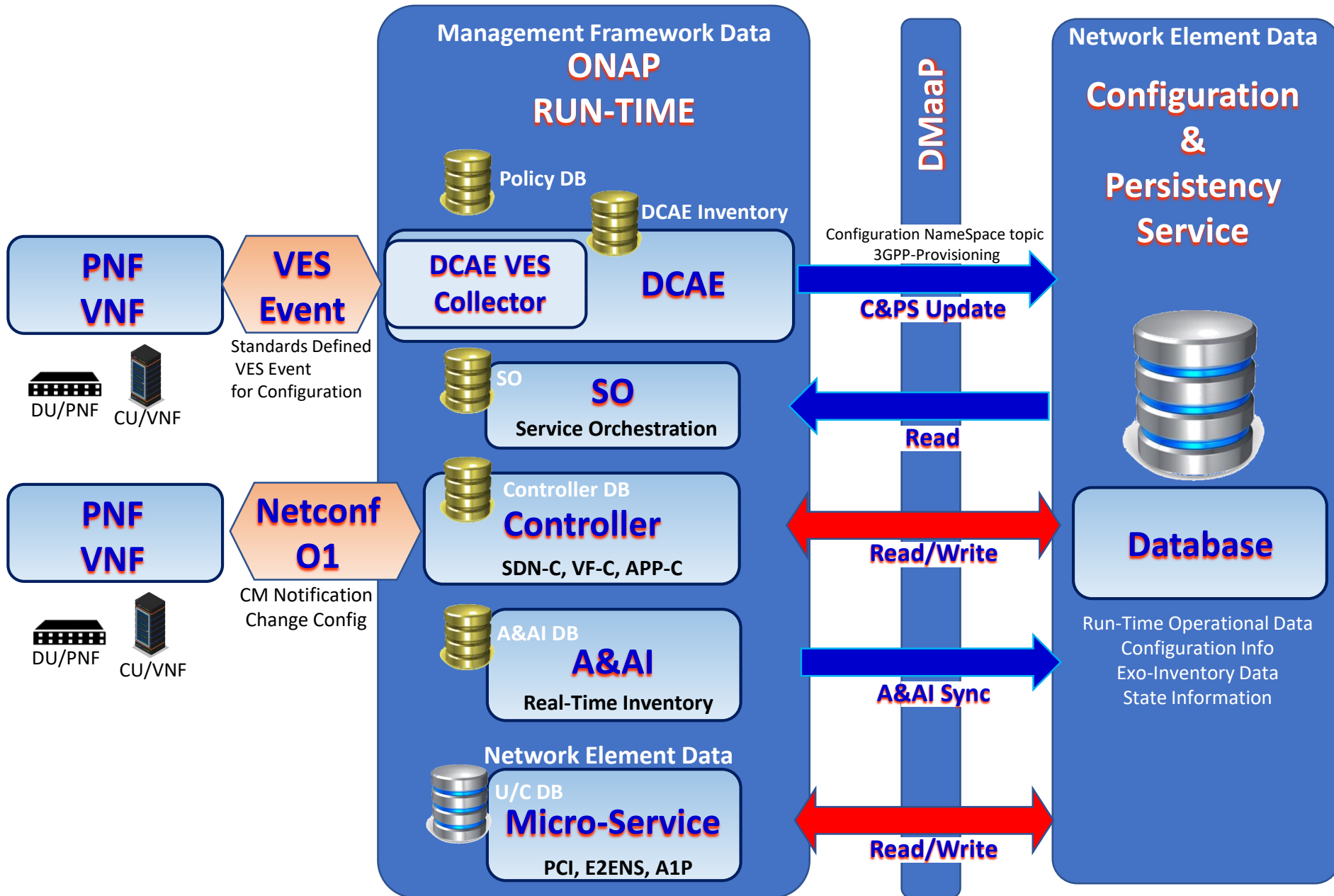

CONFIGURATION & PERSISTENCY SERVICE in R7 Guilin

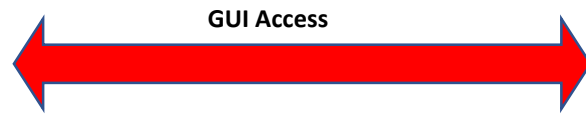
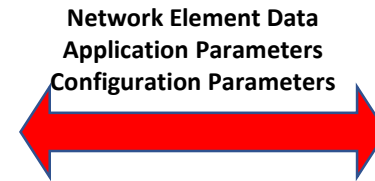
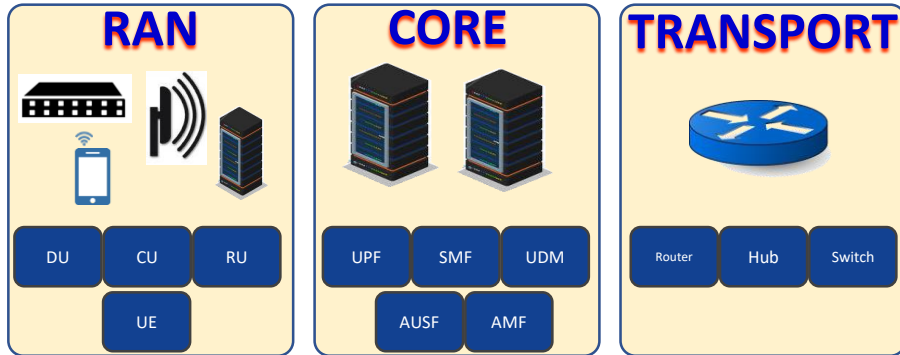

ONAP Micro-services, POCs & Use Cases

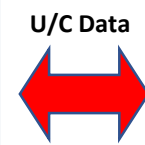
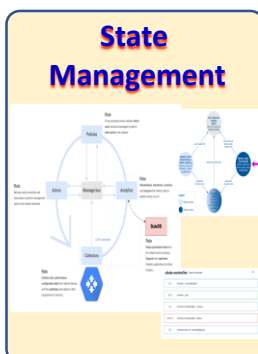
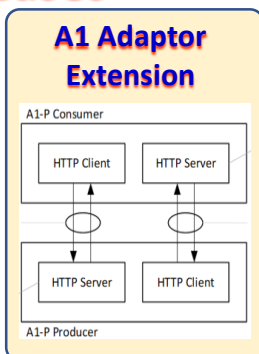
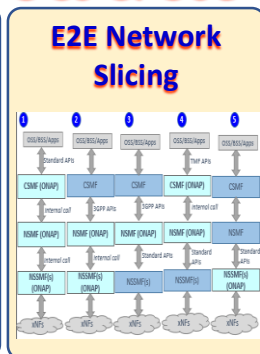
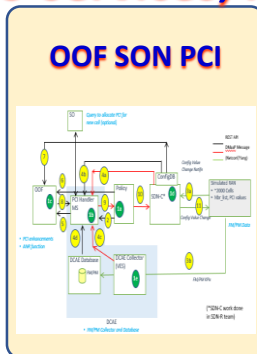
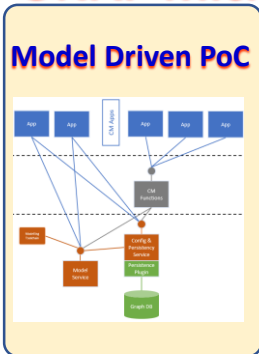

CONFIGURATION & PERSISTENCY SERVICE Overview

Configuration & Persistency Service (C&PS)

The Configuration & Persistency Service is a new platform component that is designed to serve as a data repository for Run-time data that needs to be persistent. As a stand-alone ONAP component, this project provides data layer services to other ONAP platform components and use cases that require persistent configuration or operational data. The R6 development will be enhanced as well.

REPOSITORY – The C&PS will store Network Element Configuration, State information, and Run Time data in its internal database.

DATA LAKE – The C&PS is designed to be a common services data layer for micro-services to access & store run time data.).

ARCHITECTURE REQUIREMENT IDENTITY – ROW 25

[AR-0024-R7-052020 Run Time Configuration Database / Data Persistency Service Project](#) Benjamin Cheung, Joanne Liu Rudel, Tony Finnerty [xNF](#)

EXECUTIVE SUMMARY - The RunTime Configuration Database / Data Persistency Service is a new platform component that is designed to serve as a data repository for Run-time data that needs to be persistent. As a stand-alone ONAP component, this project provides data layer services to other ONAP platform components and use cases that require persistent configuration or operational data. The R6 development will be enhanced as well.

BUSINESS IMPACT - The ability for service operators to visualize and manage data in a RAN network (PNFs, VNFs, and logical constructs) with ONAP is a critical business function because they are key Life Cycle Management (LCM) and OA&M operations. The project has business impacts to enhance the operation of data-handling within ONAP by providing efficient data layer services.

BUSINESS MARKETS - This project applies to any domain (wireless, transport, optical, and wireline) that ONAP may manage. It is not a market or geographical specific capability. It is expected that scaled ONAP installations such as Edge & Core ONAP deployments will also deploy the database across each installation.

FUNDING/FINANCIAL IMPACTS - This project represents a large potential Operating Expense (OPEX) savings for operators because of the ability to configure networks saving time and expenses.

ORGANIZATION MGMT, SALES STRATEGIES - There is no additional organizational management or sales strategies for this use case outside of a service providers "normal" ONAP deployment and its attendant organizational resources from a service provider.

R7 Model Driven C&PS PoC > Model Driven Configuration

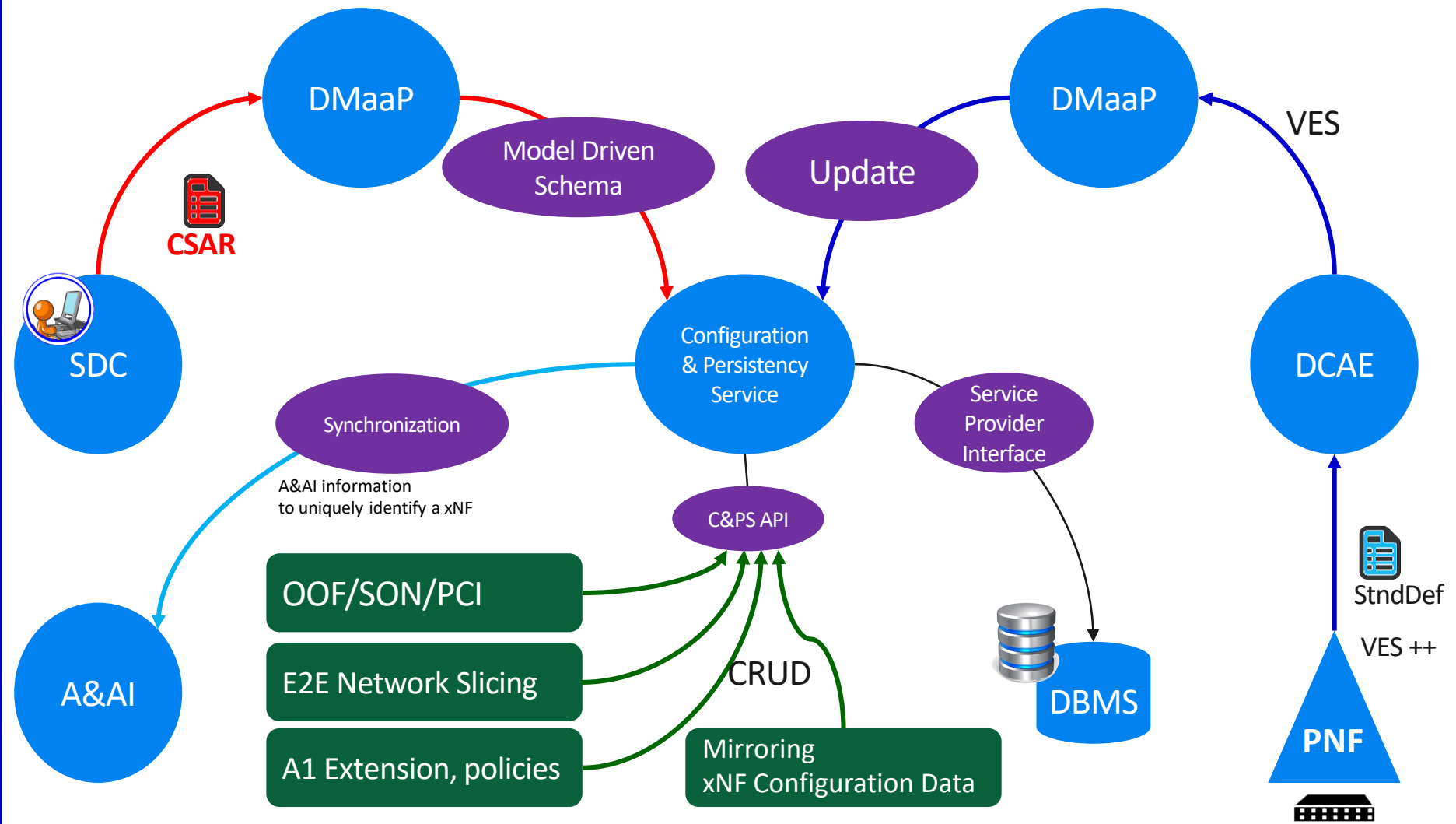
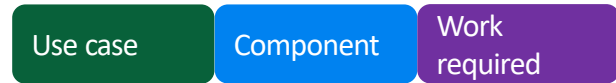



END TO END NETWORK SLICING

NETWORK SLICING in R7 Guilin

By R7 G-Release, an End to End Network Slice (including Core, RAN & Transport can be created

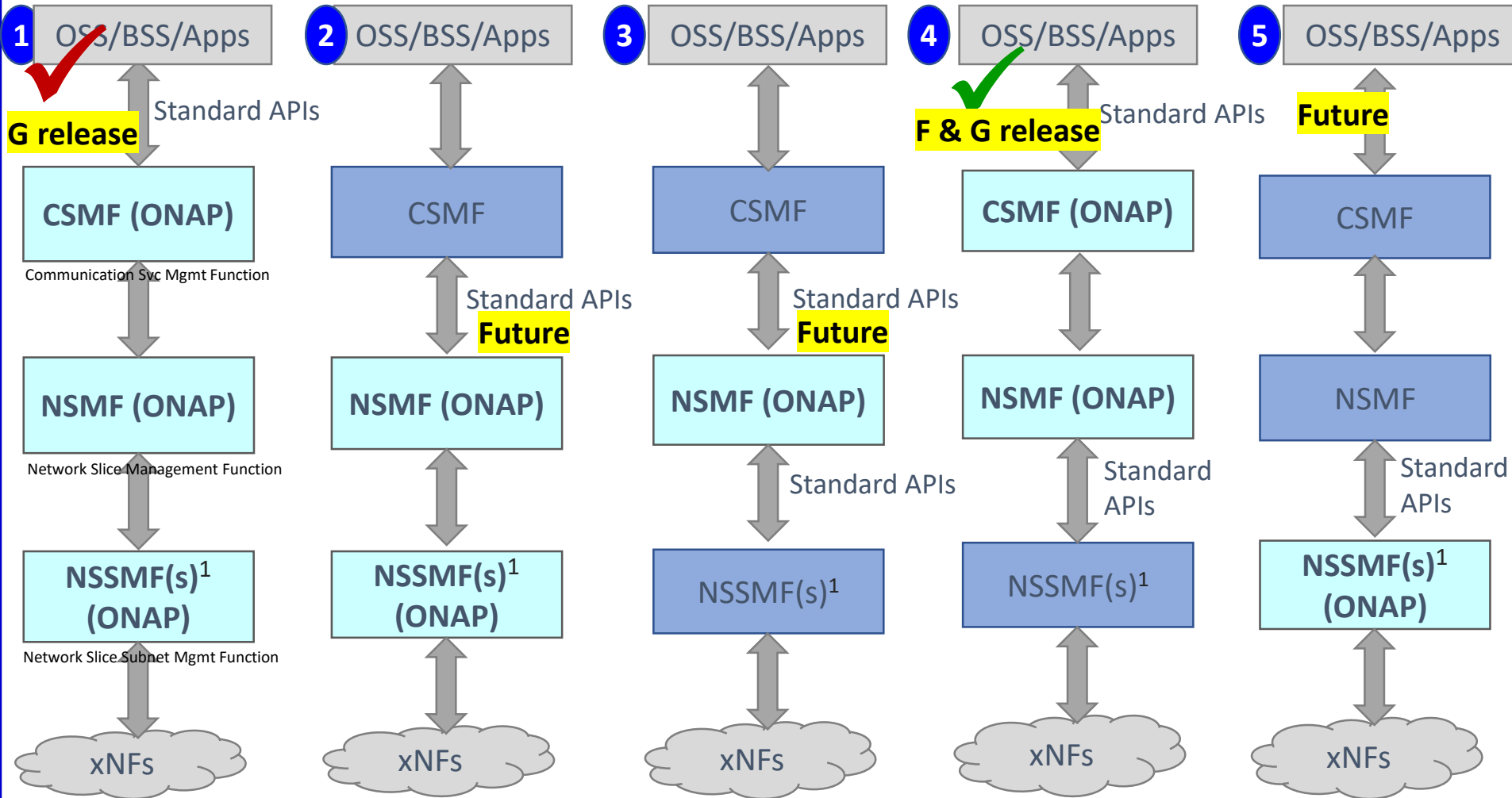

3rd party component

In F release, only Scenario 4 for Core is implemented. Scenario 1 (all 3 sub-nets) & Scenario 4 for RAN and Core will be supported in G release.

¹ Top-most NSSMF/domain-specific NSSMF – under discussion

NETWORK SLICING in R7 Guilin

Objective: Demonstrate e2e slice design, creation, activation, deactivation and termination - including **RAN, Core and Transport** slice sub-nets. Demonstrate KPI monitoring, simple Closed Loop Control & Intelligent Slicing.

Lifecycle of a Network Slice Instance

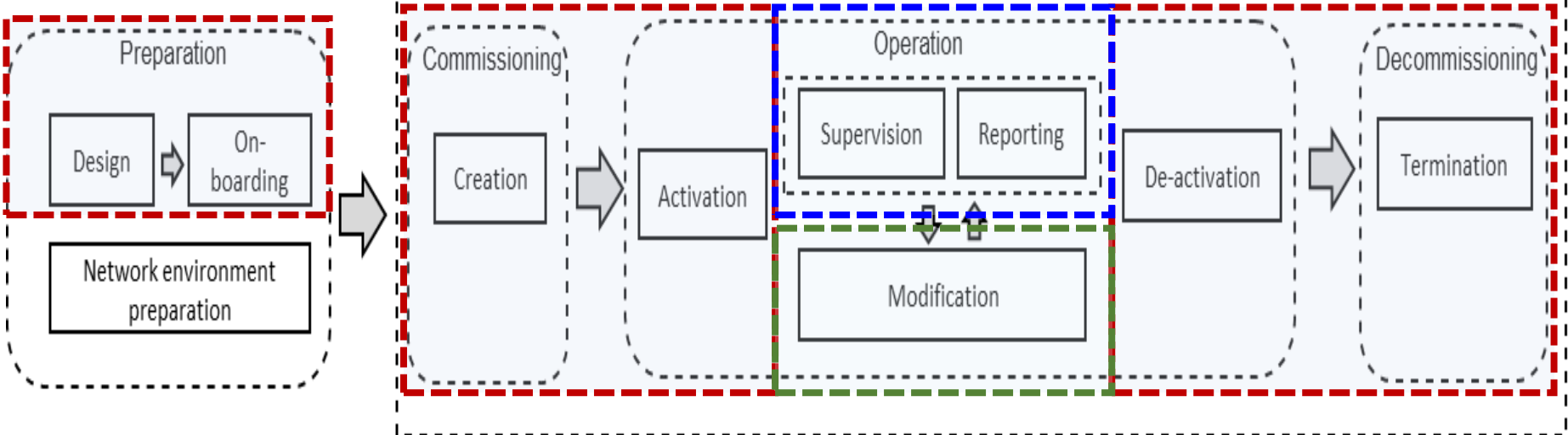

Ref.: 3GPP TS 28.530

 Scope for Frankfurt (with enhancements)

 Additional scope for Guilin (under discussion)

 Initial steps in Guilin (under discussion)

- **Design and pre-provision:** Creation of necessary slice/slice sub-net templates.
- **Creation, activation, deactivation and termination** of NSI, including its constituent slice sub-nets (RAN, Core and Transport).



ETSI Alignment Use Case

ETSI Alignment Use Case

As part of aligning ONAP to ETSI MANO, ONAP supports ETSI standards (2.7.1) for packaging, LCM operations, security for managing VNF, PNF and NS

- SOL004 standard is used for VNF and PNF packages
- SOL007 standard is used for NS package
- SOL001 standard is used to describe VNF, PNF and NS
- SOL003 standard is used for VNF Package Management, LCM and Monitoring
- SOL005 standard is used for NS/PNF/VNF Package Management, LCM and Monitoring.
- SOL002 standard is used for VNF/VNFC-level EM triggered scenarios (LCM, Fault, Performance, Configuration)
- ETSI Package and communication security are supported

ONAP components target realization of ETSI MANO

- SDC realizes SOL004 and SOL007 package onboarding, design and distribution functionalities.
- ONAP NFVO (SO NFVO & VFC) and External NFVO realize the NFVO functionalities.
- SOL003 Adapter realizes the Or-Vnfm (SOL003) interface
- SOL005 Adapter realizes the Os-Ma (SOL005) interface
- SOL002 Adapter realizes the Ve-Vnfm (SOL002) interface
- ETSI Catalog Manager provides ETSI Catalog/Package management for NS/VNF/PNF

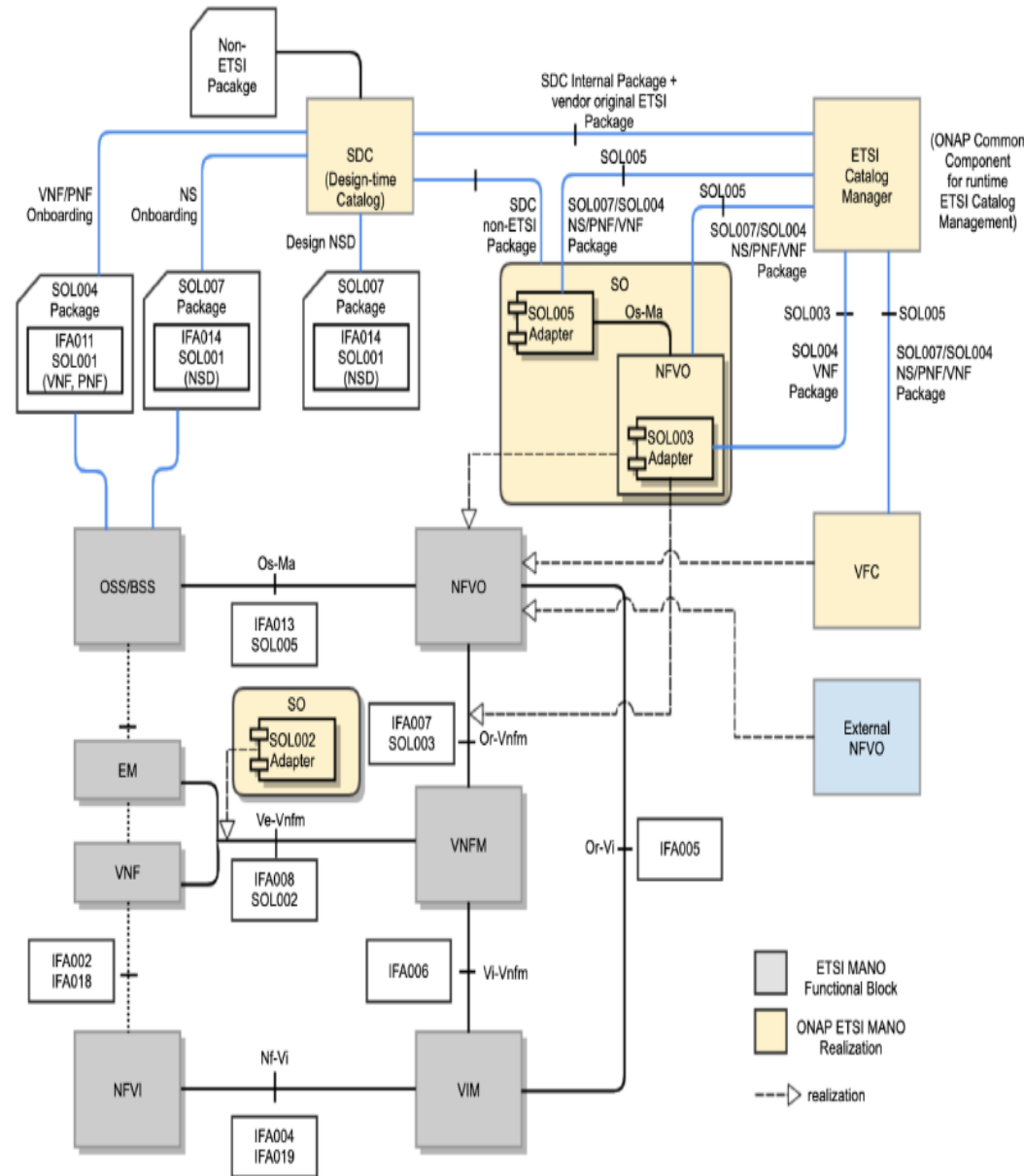

ETSI Alignment Use Case

ONAP will be aligned with ETSI standards: SOL004, SOL007, SOL001, SOL003, SOL005, SOL002

- SDC supports SOL004/SOL007 Package Onboarding
 - SDC CSAR embeds the vendor SOL004/SOL007 package in an ONAP VNF package
- ETSI Catalog Manager gets an SDC package notification and queries for the SDC package with SOL004/SOL007 package(s)
- ONAP-ETSI Catalog Manager queries for the SDC CSAR and stores the SOL004/SOL007 vendor packages in its database
- SOL003 Adapter supports VNF package management and LCM
- SOL003 Adapter forwards VNF packages to VNFM over SOL003 Package Management Interface
- SOL005 Adapter queries for NS/PNF descriptors & VNF packages
- SOL005 Adapter forwards NS/PNF descriptors & VNF packages to External NFVO
- SOL003 Adapter supports SOL003 Operations
- SOL005 Adapter supports SOL005 Operations
- SOL002 Adapter supports SOL002 Operations

Note: SOL003/SOL005/SOL002 Adapters will be designed to leverage common functionalities such as: Security, HPA, AAI, Policy, ETSI Catalog Manager

SOL005 Northbound support is not for Frankfurt

SOL003/SOL002 Adapter NBI GNFC-Ready & APPC/CDS are not for Frankfurt

SOL003 Adapter DCAE event mapping is not for Frankfurt

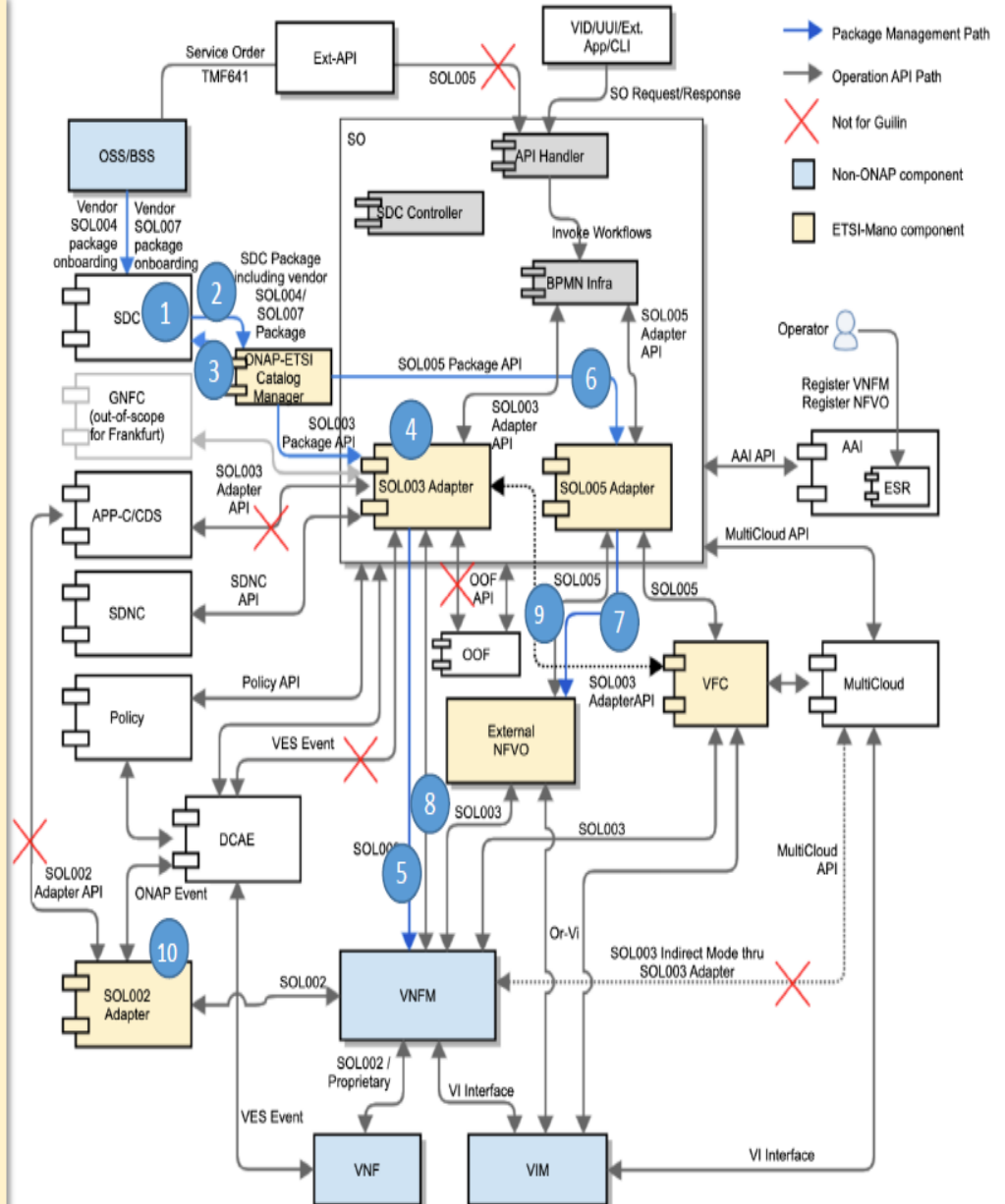

For more architecture and design details: <https://wiki.onap.org/display/DW/ETSI+Alignment+Support>

R7 Guilin PNF Support U/C SUMMARY

5G USE CASE	DESCRIPTION	Req vs U/C
PNF PRE-ONBOARDING & ONBOARDING	PNF Package delivery, Pre-onboarding and PNF Onboarding via SDC.	Requirements
PNF PLUG AND PLAY	PNF PnP handles the PNF discovery and registration by ONAP during installation & commissioning. PRH (PNF Registration Handler) enhancements	E2E Use Case
xNF S/W UPGRADE	PNF Software upgrade to update the software on a PNF. Use of Ansible/NetConf direct to PNF.	Requirements
CMPv2	Certificate Management Protocol (Will be presented in its own Lecture at the Virtual Face to Face)	Requirements



PNF PREONBOARDING / ONBOARDING

PNF PRE-ONBOARDING/ONBOARDING U/C OVERVIEW

1 PNF Package Delivery: Vendor creates & delivers PNF Package with PNF artifacts

2 PNF Pre-Onboarding: VNF-SDK (⚠️) to (create) PNF Onboarding Package & *validates* of PNF onboarding package

3 PNF Onboarding package: Package loaded

4 SDC: NF OB Package > SDC catalog

5 ONAP RT Components: Ingest and use CSAR package

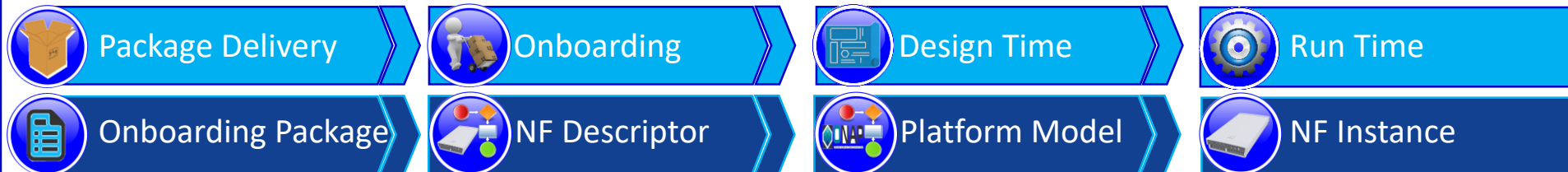
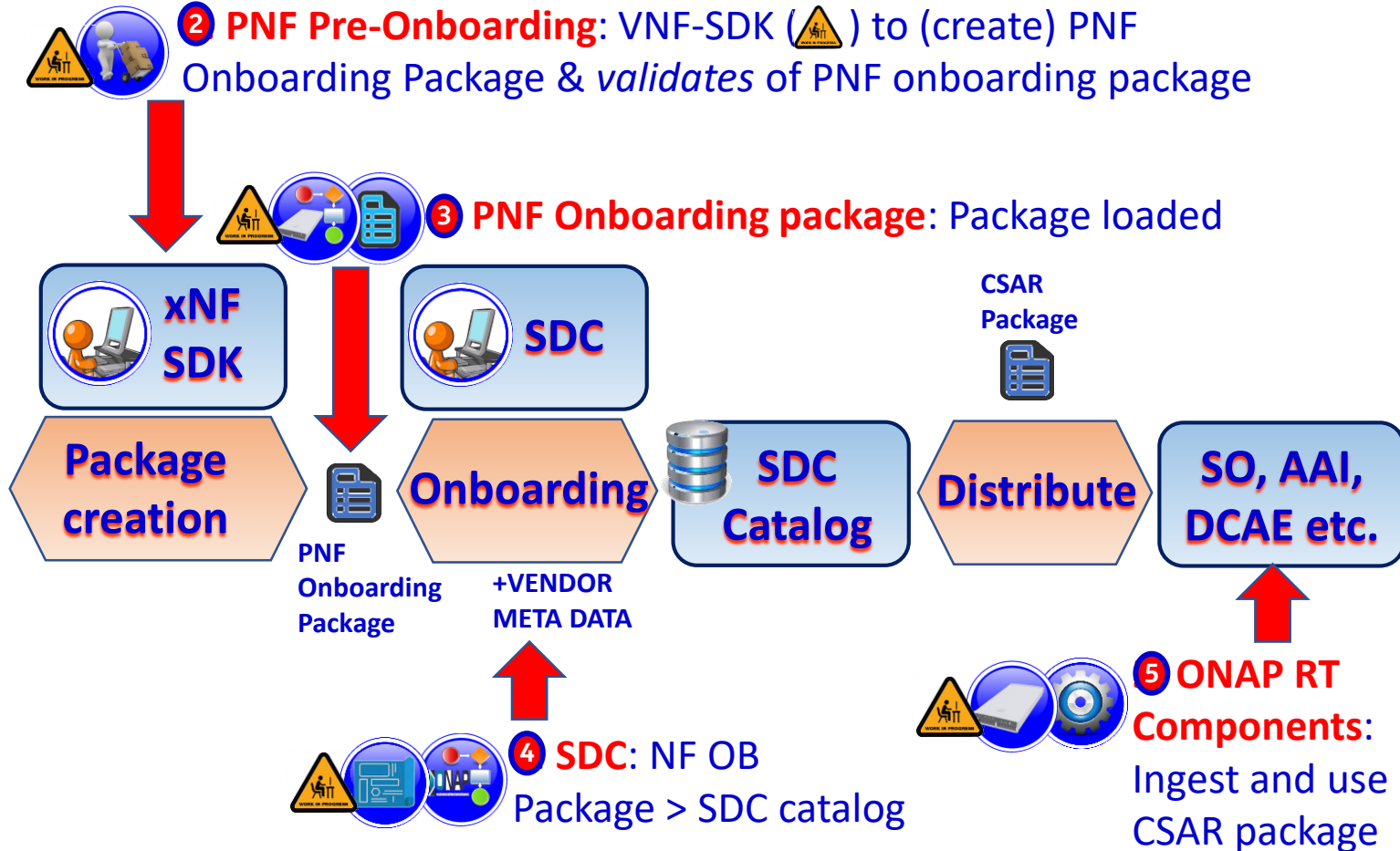
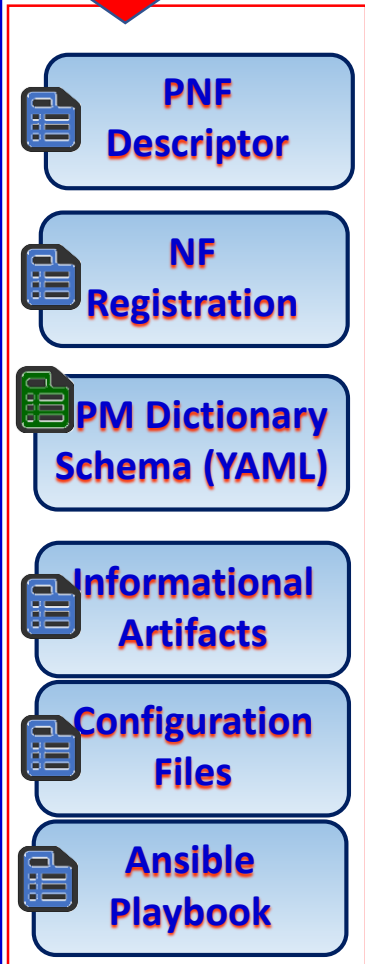

PNF PRE-ONBOARDING – Overview

ETSI GS NFV-SOL 004 V2.7.1 (2019-12)



Network Functions Virtualisation (NFV) Release 2; Protocols and Data Models; VNF Package and PNF Archive specification

5.2 VNF package manifest and certificate files

In option 1 (see clause 5.1) the manifest file provides the VNF package integrity and authenticity assurance. In this option the manifest contains the digests (hashes) for each individual file locally stored within the VNF package or referenced from it. Each file related entry of the manifest file includes the path or URI of the individual file, the hash algorithm and the generated digest. A consumer of the VNF package shall verify the digests in the manifest file by computing the actual digests and comparing them with the digests listed in the manifest file.

In option1 the VNF package authenticity is ensured by signing the manifest file with the VNF provider private key. The digital signature is stored in the manifest file itself (see clause 5.3). The VNF provider shall include an X.509 certificate [8] in the VNF Package. The certificate shall be either placed in a certificate file with extension .cert or, if the chosen signature format allows it, the certificate may be included in the signature container itself. The certificate provides the VNF provider public key.

In option 2 (see clause 5.1), the VNF package authenticity and integrity is ensured by signing the CSAR file with the VNF provider private key (option 2 in clause 5.1). The digital signature is stored in a separate file. The VNF provider shall also include an X.509 certificate. The certificate may be included in the signature itself if the signature format allows it or in a separate file. The signature and certificate files shall be siblings of the CSAR file, i.e. placed in the same folder in the parent archive. The signature file shall have an extension .cms and the same name as the CSAR file. Naming conventions for the certificate file are specified in clause 4.3.6.

In this alternative (option 2 in clause 5.1) it is not required to include digests (hashes) per each individual file or artefact in the manifest file. A consumer of the VNF package can verify the signature of the complete CSAR package with the VNF provider public key.

Table 5.2-1 summarizes the characteristics of the two possible options for integrity assurance.

Table 5.2-1: Options for VNF Package integrity assurance: summary of characteristics

Options	Digest per artifact	Signature per artefact	Support external artifacts	Signature as part of the manifest file	External Signature file for the whole CSAR	Certificate may be part of the signature	Certificate may be in a separate file
Option 1	Yes	Yes (mandatory)	Yes	Yes	No	Yes	Yes
Option 2	No	Yes (mandatory)	No	Yes	Yes	Yes	Yes

The X.509 certificate may contain one single signing certificate or a complete certificate chain. The root certificate that may be present in this X.509 certificate file shall not be used for validation purposes. Only trusted root certificate pre-installed in NFVO shall be used for validation (see clause 5.1).



PNF PLUG AND PLAY

PNF PLUG AND PLAY U/C Overview

Design Time

①



PNF Modeling

Resources Definition/Services Definition
SDC: PNF (physical element) Modeling
Distribution of types

②



PNF Instance Declaration

PNF Infrastructure Service Declaration
First part of PNF instantiation
PNF A&AI Entry created

⑮ ⑯ ⑰ ⑱ ⑲ ⑳ ㉑ ㉒



③



PNF Boot-strapping

PNF Powers up and Boot-straps
PNF performs a “Plug and Play” procedure
Equipment vendor proprietary steps

④



PNF Contacts ONAP

PNF connects to ONAP via a Registration Event
PNF Registration Handler (PRH) processes the event

㉓ ㉔ ㉕ ㉖ ㉗ ㉘ ㉙ ㉚

⑤



PNF Activation

Connection points configured
Second part of PNF service instantiation
PNF configured and ready to provide service

㉛ ㉜ ㉝ ㉞ ㉟ ㊱ ㊲ ㊳

Run-Time (Instances)

PNF PLUG AND PLAY – Overview

This Use Case will continue PNF Plug and Play development started in R3 Casablanca. Functionality that was started but not completed, and introduce some enhancements to improve Plug and Play operation.

ARCHITECTURE REQUIREMENT IDENTITY – ROW 17

[AR-0016-R7-052020](#) [R7PNFPLUG&PLAYBUILDINGBLOCK/WORK-FLOWMANAGEMENT](#) Benjamin Cheung, Damian Nowak [xNF](#)

EXECUTIVE SUMMARY - This requirement will augment the work-flow to building block management within SO for Plug and Play operation. The continues the work started in R6. The description of the "base" work which will be enhanced is shown in the wiki: [PNF PLUG and PLAY in R6 Frankfurt](#)

BUSINESS IMPACT - The enhancement to Plug and Play operation in ONAP is a critical business function because they enhance installation and commissioning activities.

BUSINESS MARKETS - This project applies to any domain (wireless, transport, optical, and wireline) that ONAP may manage.

FUNDING/FINANCIAL IMPACTS - The plug and play project has Operating Expense (OPEX) savings for operators because of the ability to saving time and expenses during installation and commissioning and contributes towards ZTM (Zero touch management).

ORGANIZATION MGMT, SALES STRATEGIES - There is no additional organizational management or sales strategies for this use case outside of a service providers "normal" ONAP deployment and its attendant organizational resources from a service provider.

PNF PLUG AND PLAY – Overview

Proposed building blocks

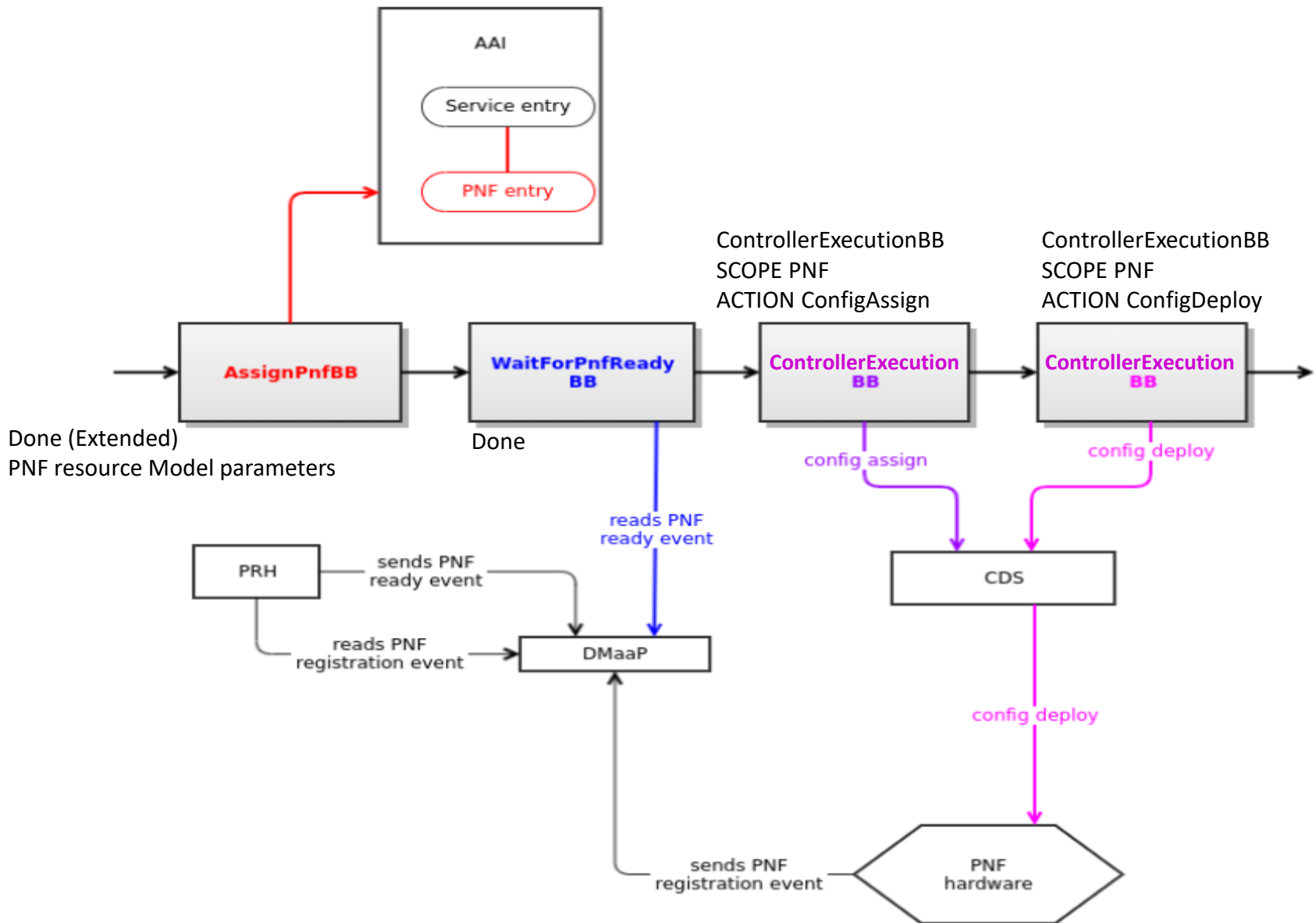

PNF PLUG AND PLAY & Licensing Management

R7 Guilin

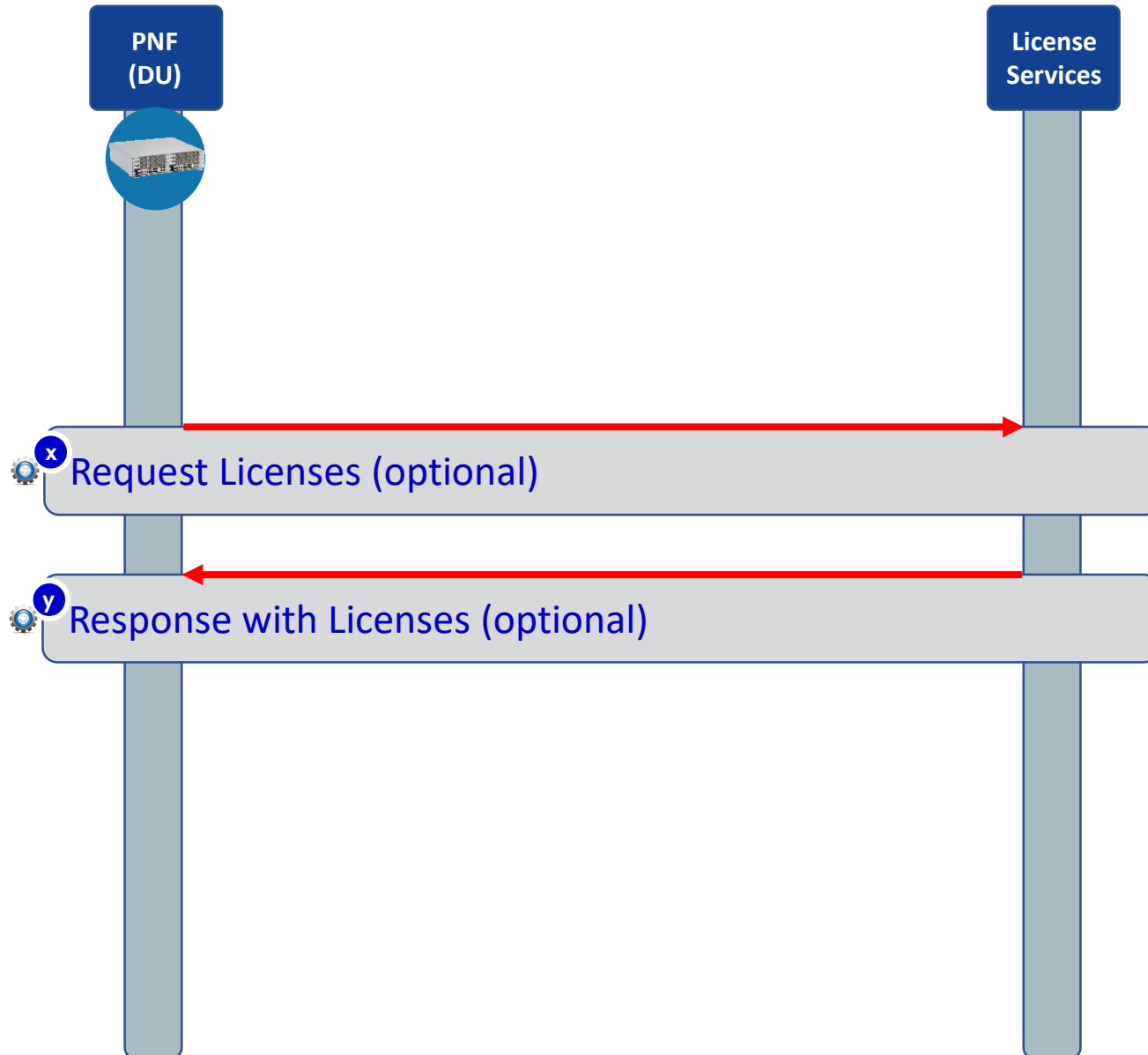

PNF PLUG AND PLAY for R7 Guilin

Wiki

<https://wiki.onap.org/display/DW/R7+PNF+Plug+and+Play+PnP>

R7 Guilin NEW COMPONENT CAPABILITIES

R7 NEW COMPONENT CAPABILITIES	DESCRIPTION
AAF / CMPv2 (Dependency)	(Dependent CMPv2 work) Security enrollment enhancements integration with DCAE. Code merging with OOM. Using CMPv2. R6 REQ-140 CMP client/server work done; Integration work (see later slides)
SO (Integration)	(Ericsson) Service configuration to PNF by controller (Step 37) NetConf. Impact to inventory (A&AI) BB based W/F connected to Configuration Steps to integrate & complete.
Licensing Management (Dependency)	(Dependency) Enhancements for requesting License Key File (LKF) & Licenses from License Service (message exchange) Flow still being defined by the Use Case team
AssignPNF BB – SO work	Done (Extended) PNF resource Model parameters
ControllerExecution BB – SO work	BB execution Framework, extended to understand PNFs. Preparing input object used for different BBs. Framework needs to take into PNFs. (Possible debug/work) (Testing & Integration Work). Environment where this is run Model parameters added, address the right CDS Blueprint.



PNF SOFTWARE UPGRADE

xNF S/W UPGRADE / with schema update in R7 Guilin

➤ Design time

- Updating the xNF resource template using vendor provided new onboarding package
- Updating and distributing the network service template with the updated resource template

➤ Run Time: executing a new service level workflow

- Upgrading a service instance and its resource instances based on the updated templates
- Updating the xNF schema (e.g. software version, artifacts) at xNF instance software upgrade completion
- Updating the network service schema at network service upgrade completion

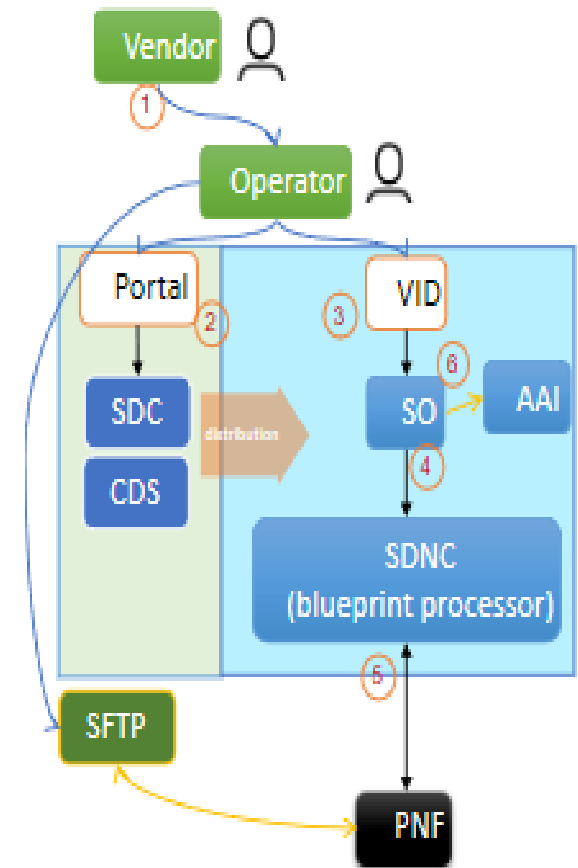

xNF S/W UPGRADE / with schema update in R7 Guilin

Support xNF Software Upgrade in association to schema update

A schema update in relation to a xNF software upgrades is a routine for network upgrade to support new xNF features, improve efficiency or increase xNF capacity on the field, and to eliminate bugs. This use case provides to ONAP an advantage in orchestrating and managing the Life Cycle of a Network Services in-line with business and service objectives

Key Contacts: Zu Qiang (Ericsson), Lukasz Rajewski (Orange), Ajay Mahimkar (AT&T), Chris Rapposelli-Manzo

<https://wiki.onap.org/pages/viewpage.action?pageId=81400388>

R7 CANDIDATE ENHANCEMENTS

IMPACT

SDC

Updating the xNF resource template from a vendor provided new onboarding package

SO

Introducing a new service level workflow

- Upgrading a service instance and its resource instances based on the updated templates
- Updating the xNF schema (e.g. software version, artifacts) at xNF instance software upgrade completion
- Updating the network service schema at network service upgrade completion



CERTIFICATE MANAGEMENT PROTOCOL CMPv2

CERTIFICATE MANAGEMENT PROTOCOL (CMPv2)

Req Use Case - DESCRIPTION

The Certificate Management Protocol (CMP) is an Internet protocol used for obtaining X.509 digital certificates in a public key infrastructure (PKI). It is described in RFC 4210 and is one of two protocols so far to use the Certificate Request Message Format (CRMF), described in RFC 4211, with the other protocol being Certificate Management over CMS (CMC), described in RFC 5273. An obsolete version of CMP is described in RFC 2510, the respective CRMF version in RFC 2511. CMP messages are encoded in ASN.1, using the DER method and usually transported over HTTP. CMP (Certificate Management Protocol) Server & Client (completed in R6)

ARCHITECTURE REQUIREMENT IDENTITY – ROW 18

[AR-0017-R7-052020 Guilin release - functional requirements proposed list#R7ONAPSECURITY-CMPv2SERVER/CLIENTINTEGRATION](#) Benjamin Cheung, Pawel Baniewski, Hampus Tjäder [xNF](#)

BUSINESS DRIVERS

EXECUTIVE SUMMARY - This requirement improves ONAP Security with CMPv2. CMP is used by multiple operations including Plug and Play, and NetConf operation. In R6 CMPv2 Certificate Service and basic development was implemented. Integration with server & client to the certificate service will be completed. There are also two ONAP bordering clients to integrate with the certificate service with interfaces to (SDN-C = Done) and DCAE. DCAE interoperation with CMPv2. REQ-140

BUSINESS IMPACT - The enhancement to CMPv2 operation will improve security management within ONAP and affects multiple ONAP functions and use cases, including Plug and Play (PNF registration) and NetConf. As with all security functionality within ONAP, Security is a fundamental aspect of FCAPS, being the "S" for security management.

BUSINESS MARKETS - This project applies to any domain (wireless, transport, optical, and wireline) that ONAP may manage.

FUNDING/FINANCIAL IMPACTS - Potential OPEX savings with enhanced security to prevent breaches and prevent security compromises.

ORGANIZATION MGMT, SALES STRATEGIES - There is no additional organizational management or sales strategies for this use case outside of a service providers "normal" ONAP deployment and its attendant organizational resources from a service provider.

CERTIFICATE MANAGEMENT PROTOCOL (CMPv2)

CMP in the TCP/IP model:

application	CMP	CMP			
		HTTP	HTTPS	SMTP	..
transport		TCP			
Internet		IP (IPv4, IPv6)			
link	Ethernet	Token Bus	Token Ring	FDDI	..

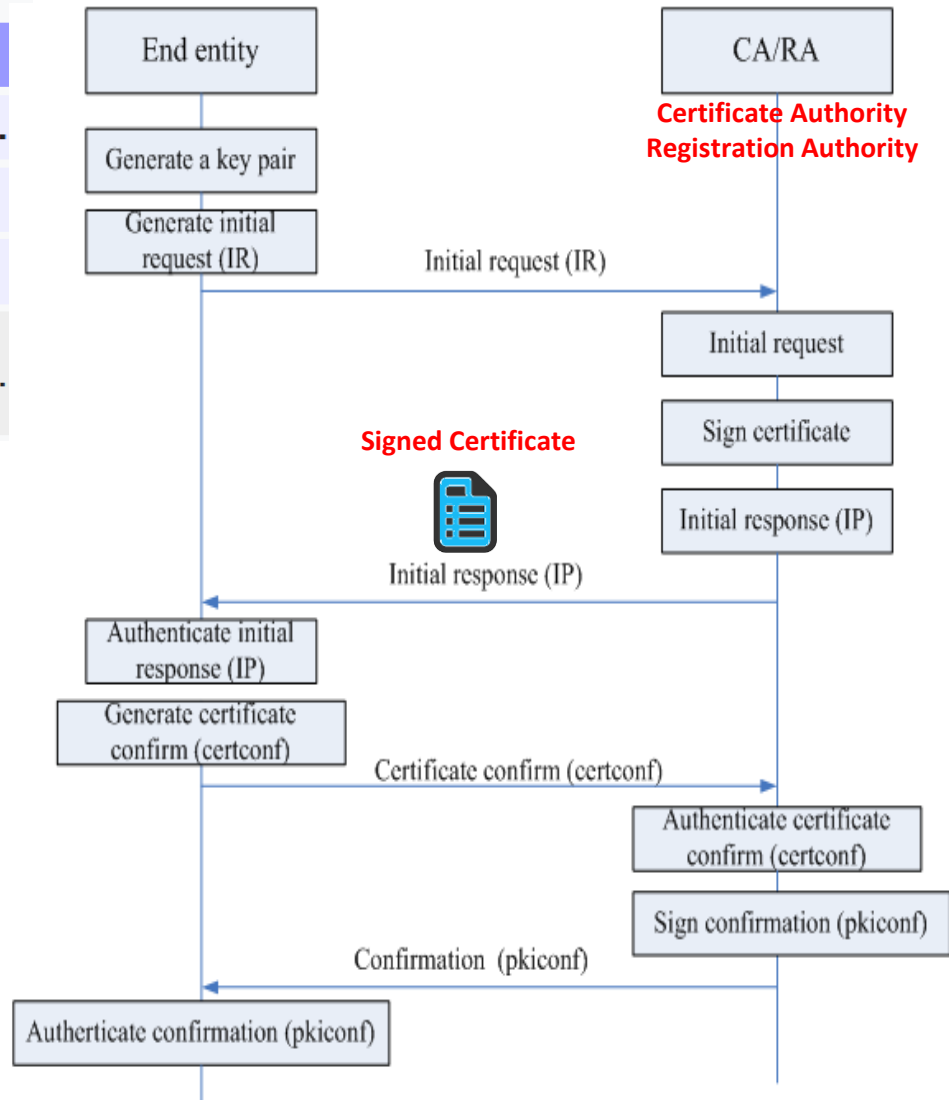



MDONS

Multi Domain Optical Network Services (MDONS)

Automate the service design & activation from an optical (L0/L1) service request that requires "off-net" resources to complete, requiring coordination between two or more service providers.

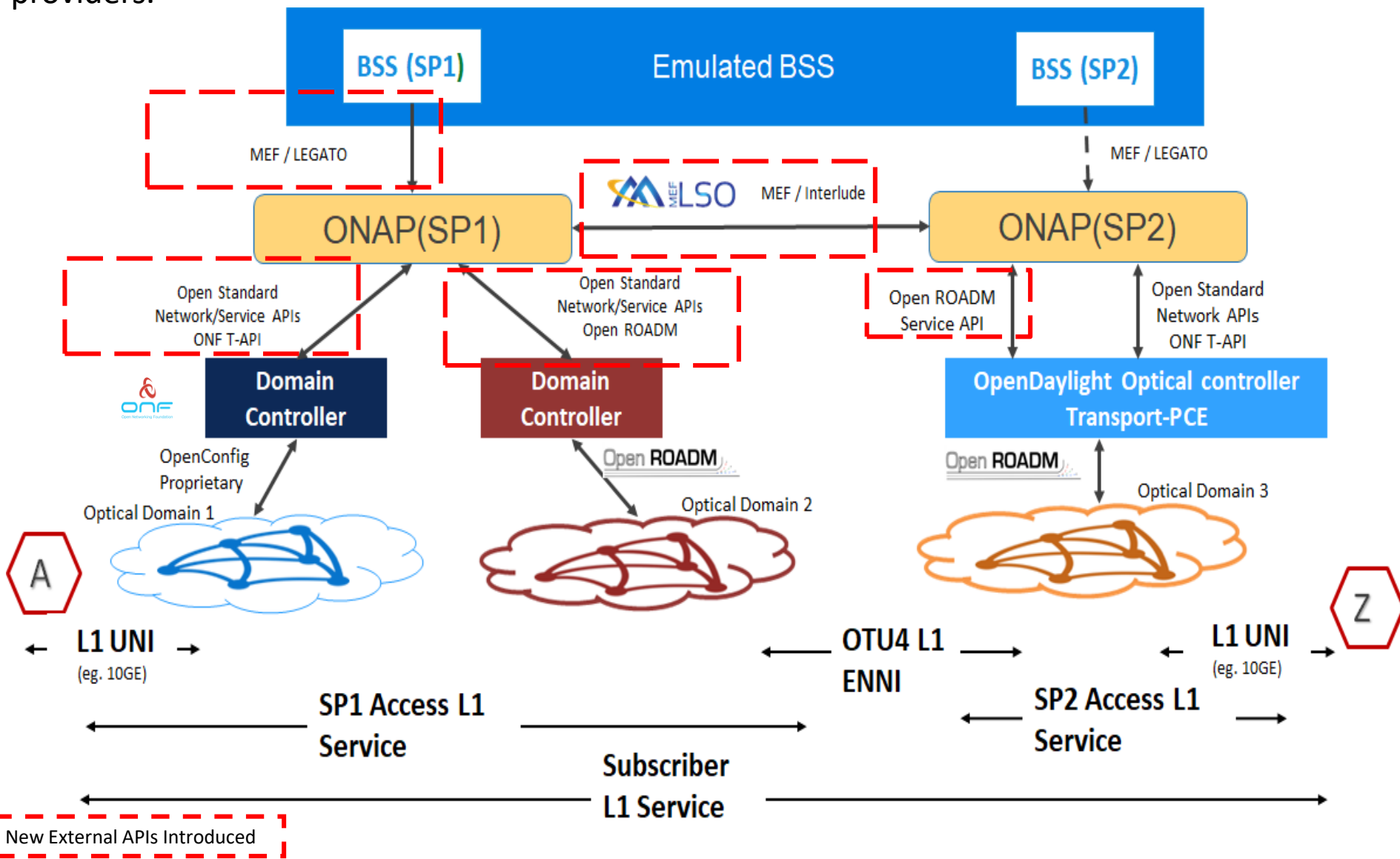

Multi Domain Optical Network Services (MDONS)

node1

→ Xponder/NE

A

→ Port

—

→ Link

Service Provider 1

Service Provider 2

UNI

10G

A

node 1

Domain1

ROADM network

node 2

Z

UNI

10G

UNI

10G

A

node 3

Domain1

TAPI network

node 4

Z

ENNI

100G

