

R8 Honolulu Architecture Reviews

- Plug and Play, IPv4/IPv6, CMPv2, Standard Defined VES
- ONAP Requirements & Architecture Subcommittees

R8 Honolulu Requirements

REQUIREMENT	DESCRIPTION	Arch Requirement #
PNF Plug and Play	Continuation of PNF Plug and Play from R2 Beijing, adding VID support in R8	
CMP v2	Certificate Management Protocol v2 enhancements in R8	
IPv4 / IPv6	Support for dual stack IPv4/IPv6	
Standard Defined VES	Continuation of Standard Defined VES Development in R8	



ARCHITECTUE SUB-COMMITTEE PRESENTATIONS



R8 PNF PLUG AND PLAY



- R8 Architecture Sub-committee Presentation

PNF PLUG AND PLAY U/C Overview R2-R5



Design Time

①



PNF Modeling

Resources Definition/Services Definition
SDC: PNF (physical element) Modeling
Distribution of types

②



PNF Instance Declaration

PNF Infrastructure Service Declaration
First part of PNF instantiation
PNF A&AI Entry created

15 16 17 18 19 20 21 22



③



PNF Boot-strapping

PNF Powers up and Boot-straps
PNF performs a “Plug and Play” procedure
Equipment vendor proprietary steps

Run-Time (Instances)

④



PNF Contacts ONAP

PNF connects to ONAP via a Registration Event
PNF Registration Handler (PRH) processes the event

25 26 27 28 29 30 31

⑤



PNF Activation

Connection points configured
Second part of PNF service instantiation
PNF configured and ready to provide service

34 35 36 37 38 39 40 41 42

PNF PLUG AND PLAY U/C Overview R2-R5

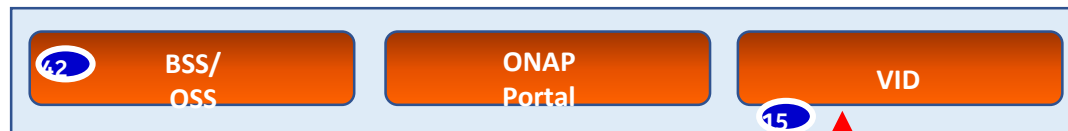

ONAP Deployment

DESIGN-TIME



RUN-TIME

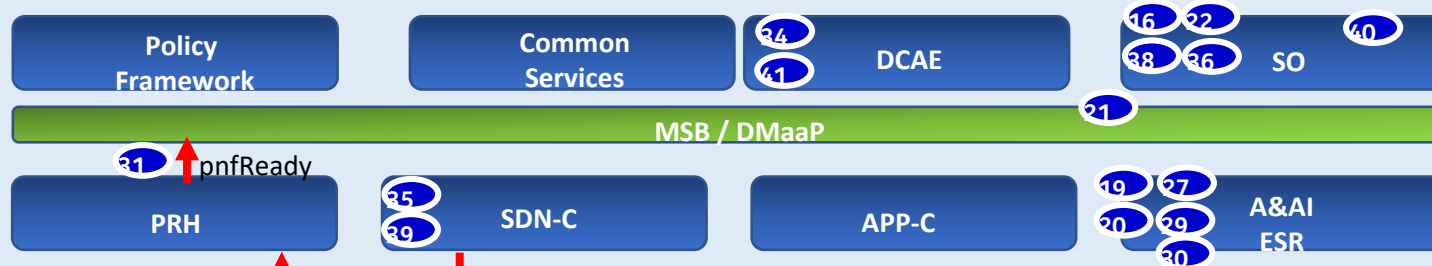

Service Instantiation

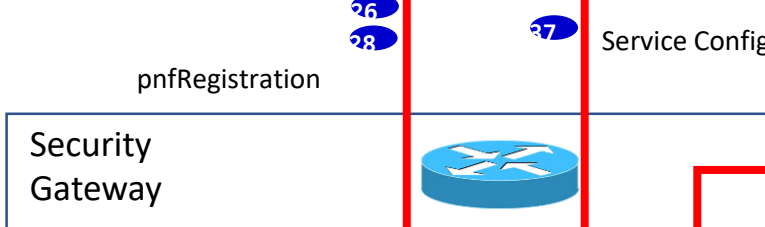

Service Configuration (37)

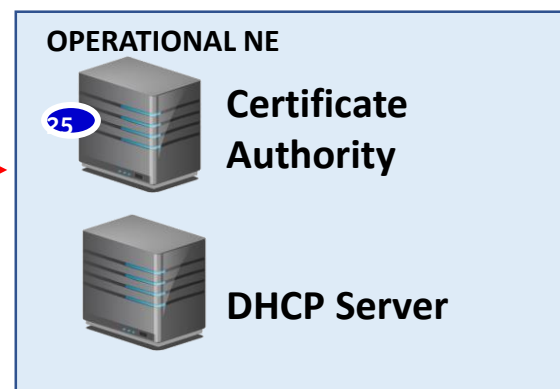

5G DU (PNF)

PNF PLUG AND PLAY – R8 Overview



The PNF Plug and Play Use Case allows a PNF to register with ONAP using a pnfRegistration VES Event. This is expected to be used for installation & commissioning a network that is to be managed by ONAP. When this event is received, the PNF Registration Handler (PRH) processes this event to complete the registration by updating the corresponding A&AI entry for the expectant PNF. The PRH was developed specifically for this use case. Once registered, ONAP can interoperate with the PNF and perform LCM or FCAPS (OA&M) operations in addition to other actions. This Use Case was originally started in R2 Beijing and functionality has been continually improved since then.

ARCHITECTURE REQUIREMENT IDENTITY – ROW 17

[AR-0016-R7-052020](#) [R7PNFPLUG&PLAYBUILDINGBLOCK/WORK-FLOWMANAGEMENT](#) Benjamin Cheung, Damian Nowak [xNF](#)

EXECUTIVE SUMMARY - This requirement will introduce: #1 VID work to complement the work-flow to building block management work in SO for Plug and Play. The continues the work started in R6 and R7 where the SO work-flow to building block work was finished. The description of the "base" work was done in R6/R7 and can be found in the PnP pages for those releases. In R8, VID software "front end" will be added to allow for a user to more easily use the SO Building Blocks. #2 Investigation on how the Place Model might be used

BUSINESS IMPACT - The enhancement to Plug and Play operation in ONAP is a critical business function because they enhance installation and commissioning activities.

BUSINESS MARKETS - This project applies to any domain (wireless, transport, optical, and wireline) that ONAP may manage.

FUNDING/FINANCIAL IMPACTS - The plug and play project has Operating Expense (OPEX) savings for operators because of the ability to saving time and expenses during installation and commissioning and contributes towards ZTM (Zero touch management).

ORGANIZATION MGMT, SALES STRATEGIES - There is no additional organizational management or sales strategies for this use case outside of a service providers "normal" ONAP deployment and its attendant organizational resources from a service provider.



VID



VID

Virtual Infrastructure Deployment

Provides Interface of instantiating and managing VNF Lifecycle. Interface for Deployment, instantiation, Change management operations

In R8, PNF PnP VID Front end to SO Building Block deployment is developed

SO

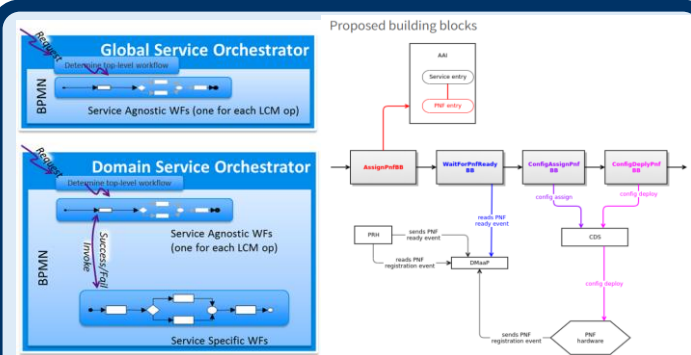

Provides work-flow execution with building blocks

In R7, SO Building Block was completed



SO Building Block work in R7

Proposed building blocks

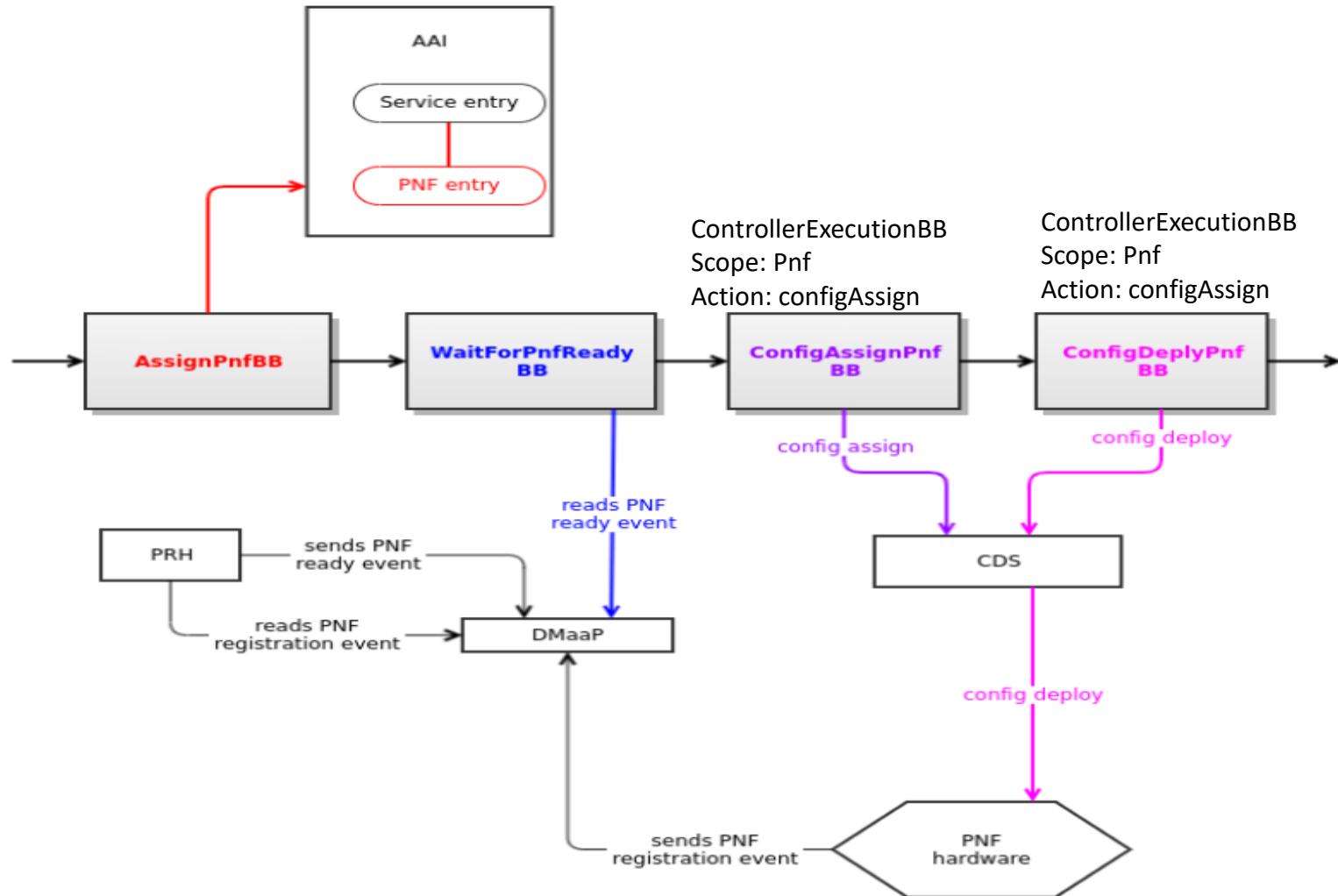

Provides work-flow execution with building blocks



VID



VID

Virtual Infrastructure Deployment

Provides Interface of instantiating and managing VNF Lifecycle. Interface for Deployment, instantiation, Change management operations

Create orchestration PNF forms which allow us to create Requests towards SO GR / API. Following SO Building Blocks Implemented on SO side. Know what we need to send to SO Creating SO API request (already exists from R7) NEW: VID calling SO API Modifying VID, ask instance name Ask relevant parameters. Create SO API

In R8, PNF PnP VID Front end to SO Building Block deployment is developed

R7 Place Geolocation Model Development



Place Model in Platform Information Model

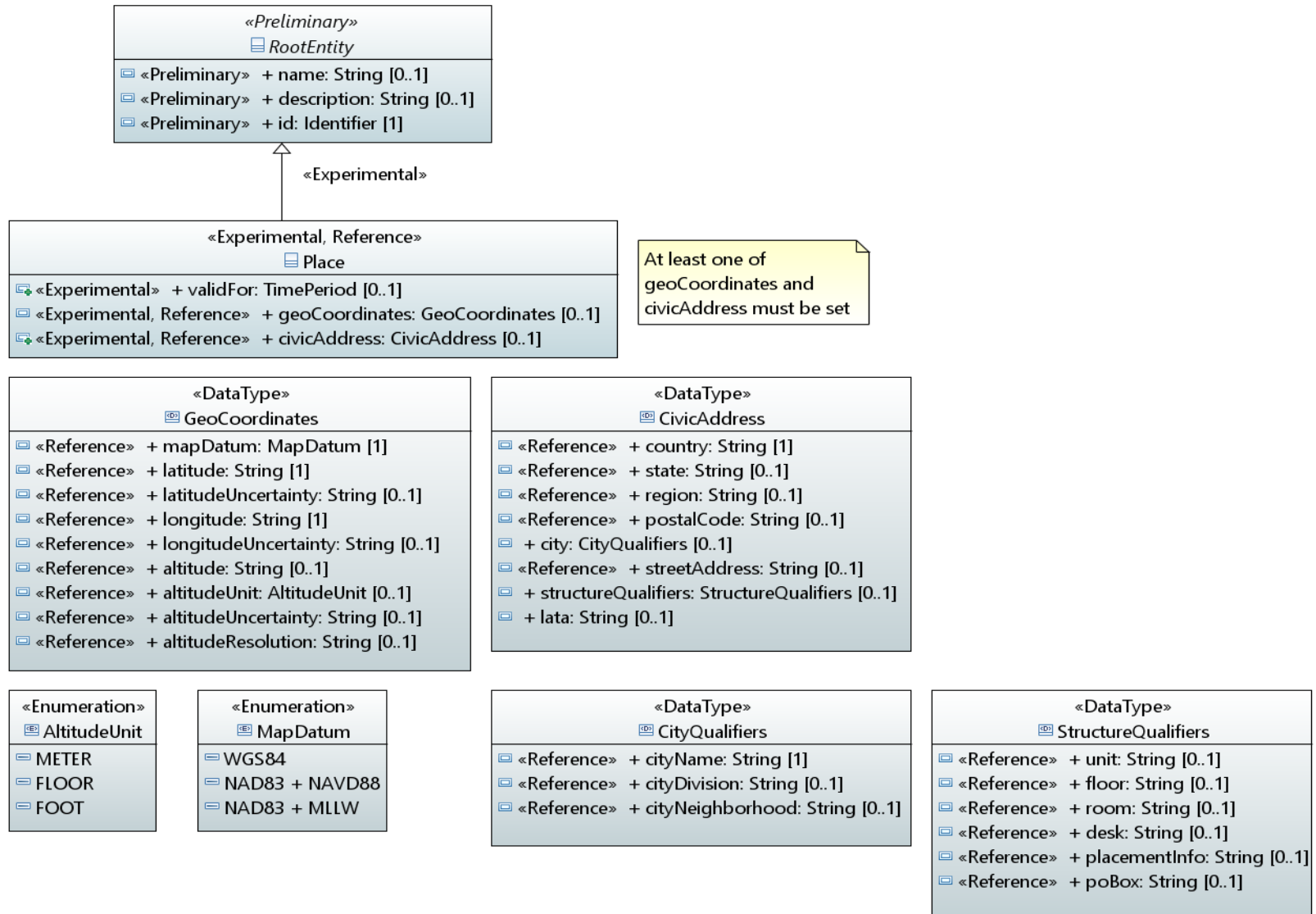

R7 Place Geolocation Model Development



Place Model in Platform Information Model

ATTRIBUTE	DESCRIPTION	EXAMPLE	TYPE	NOTES
physical-location-id	Unique identifier for physical location, e.g., CLLI (Location ID)	cli Code	String	
data-center-code	Data center code which can be an alternate way to identify a complex	example-data-center-code-val-6667	String	(Data Center centric - may need adaptation for PNF)
complex-name	Gamma complex name for LCP instance.	cli2	String	(ibid)
identity-url	URL of the keystone identity service	example-identity-url-val-28399	String	(ibid)
resource-version	Used for optimistic concurrency. Must be empty on create, valid on update and delete.		String	
physical-location-type	Type, e.g., central office, data center.	example-physical-location-type-val-28399	String	
street address	A string describing the street address of the place.	example-street1-val-28399	Map	Tag Value Array (Name/Value) = (1) "Street value #1=String" ; (2)"Street value #2=String"
city	The name of the metropolitan area, city, township, borough, district, or ward. The Map has with further specific city sub-divisions such as: division, borough, district, ward, chou, neighborhood, block, street group	example-city-val-28399	Map	Map of City (City, Township, Parish) City Division (Borough, District, Ward, Chou) Neighborhood (Block, Street groups)
state	The name of the state, province	example-state-val-28399	String	
postal-code	The string for the postal code or zip code	example-postal-code-val-28399	String	
country	The name of the country	example-country-val-28399	String	
region	The name of the region	example-region-val-28399	String	
additional qualifiers	These are additional descriptive qualifiers (general string) that may be concatenated information representing the structure qualifiers. This is a map, a tag value array of pre-defined qualifier fields including: unit, floor, room, desk	Tag Value Array	Map	
latitude	Latitude in binary geodetic form. A 34-bit fixed-point value consisting of 9 bits of integer and 25 bits of fraction. From RFC6225 (Optional)	example-latitude-val-28399	String	
longitude	Longitude in binary geodetic form. A 34-bit fixed-point value consisting of 9 bits of integer and 25 bits of fraction. From RFC6225 (Optional)	example-longitude-val-28399	String	
elevation	A 30-bit value defined by the Altitude Type field. From RFC6225 (Optional)	example-elevation-val-28399	String	
location-name	the location name (CANDIDATE)		String	
lata	Local Access Transport Area (1920s) (CANDIDATE)	example-lata-val-28399	String	
ctag-pools	CE VLAN IDs		Array	#/definitions/ctag-pool
relationship-list			Object	#/definitions/relationship
Latitude Uncertainty	(Candidates from RFC6225)	When the Ver field = 1, this field represents latitude uncertainty. Uncertainty = $2^{(21 - x)}$. $x = 21 - \text{ceil}(\log_2(\text{uncertainty}))$	String	
Longitude Uncertainty	(Candidates from RFC6225)	When the Ver field = 1, this field represents longitude uncertainty. Uncertainty = $2^{(21 - x)}$. $x = 21 - \text{ceil}(\log_2(\text{uncertainty}))$	String	
Altitude Uncertainty	(Candidates from RFC6225)	When the Ver field = 1, this field represents altitude uncertainty.	String	
Altitude Type	(Candidates from RFC6225)	(1) Altitude in Meters, (2) Altitude in Floors.	String	
Altitude Resolution	(Candidates from RFC6225)	value encodes the number of high-order altitude bits that should be considered valid	String	
Map Datum	(Candidates from RFC6225)	The Map Datum used for the coordinates given in this option: WGS84, NAD83 + NAVD88, NAD83 + MLLW.	String	
Geographic Geometry	TMForum GB922	Modeling sub-team has considered and discussed inclusion of (surfaces, multi-points, and shapes) and concluded that for now, there are immediate use cases that would need this.	Object	



SO Building Block work in R7

Proposed building blocks

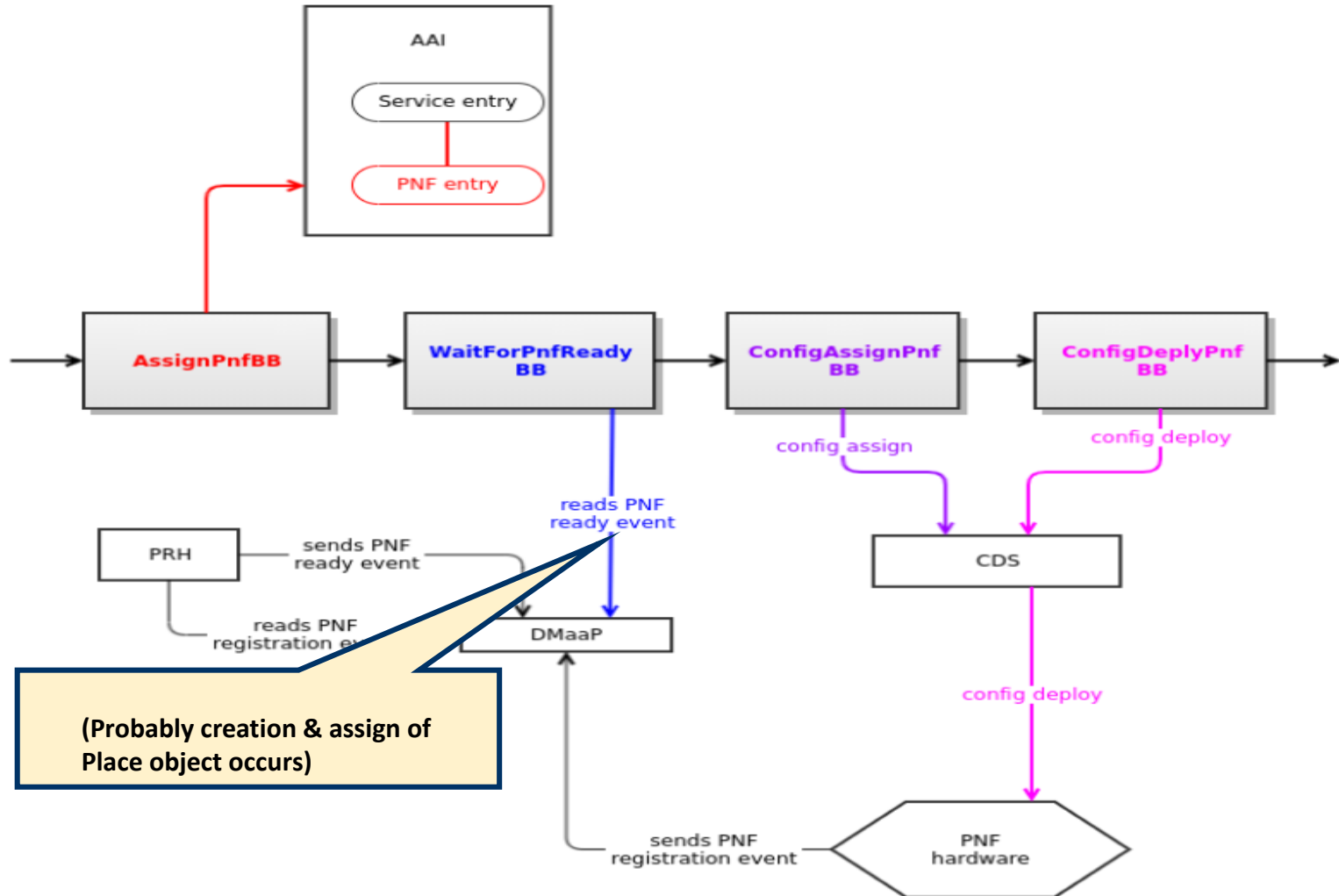

Provides work-flow execution with building blocks

PNF PLUG AND PLAY – Support for Place Model in R8



ONAP INFO-MODEL: PLACE OBJECT

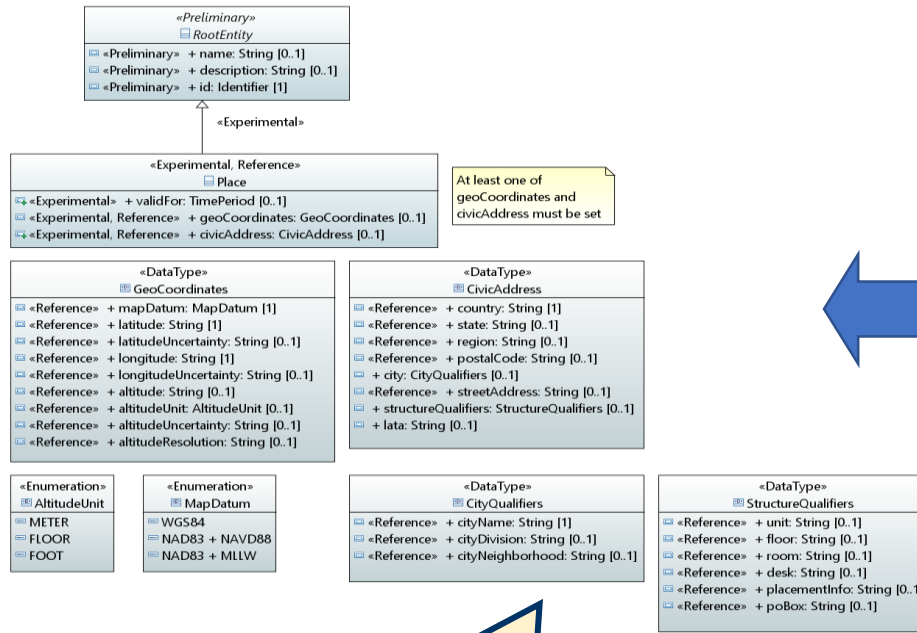

SO BB Execution

During Plug and Play, the SO Building Block will instantiate a PNF A&I entry which associated with a PLACE Object.

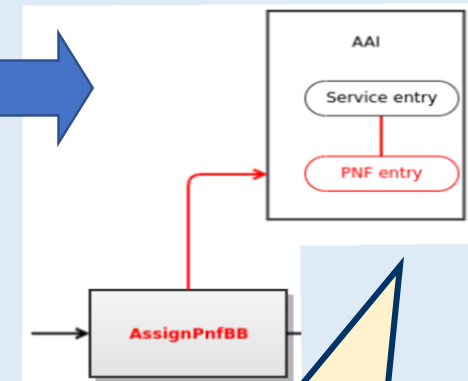

In R6 & R7, the Place Object platform information model was developed & approved (???) to be STUDIED

In R8, during the AssignPnfBB, SO needs to associate the PNF AAI entry with a Place object (???) to be STUDIED

In R8, a study will be done to figure out how to use this; no code will necessarily be done.

PNF PLUG AND PLAY – Licensing in R7



Stage x: PNF PnP & Vendor Specific License Service

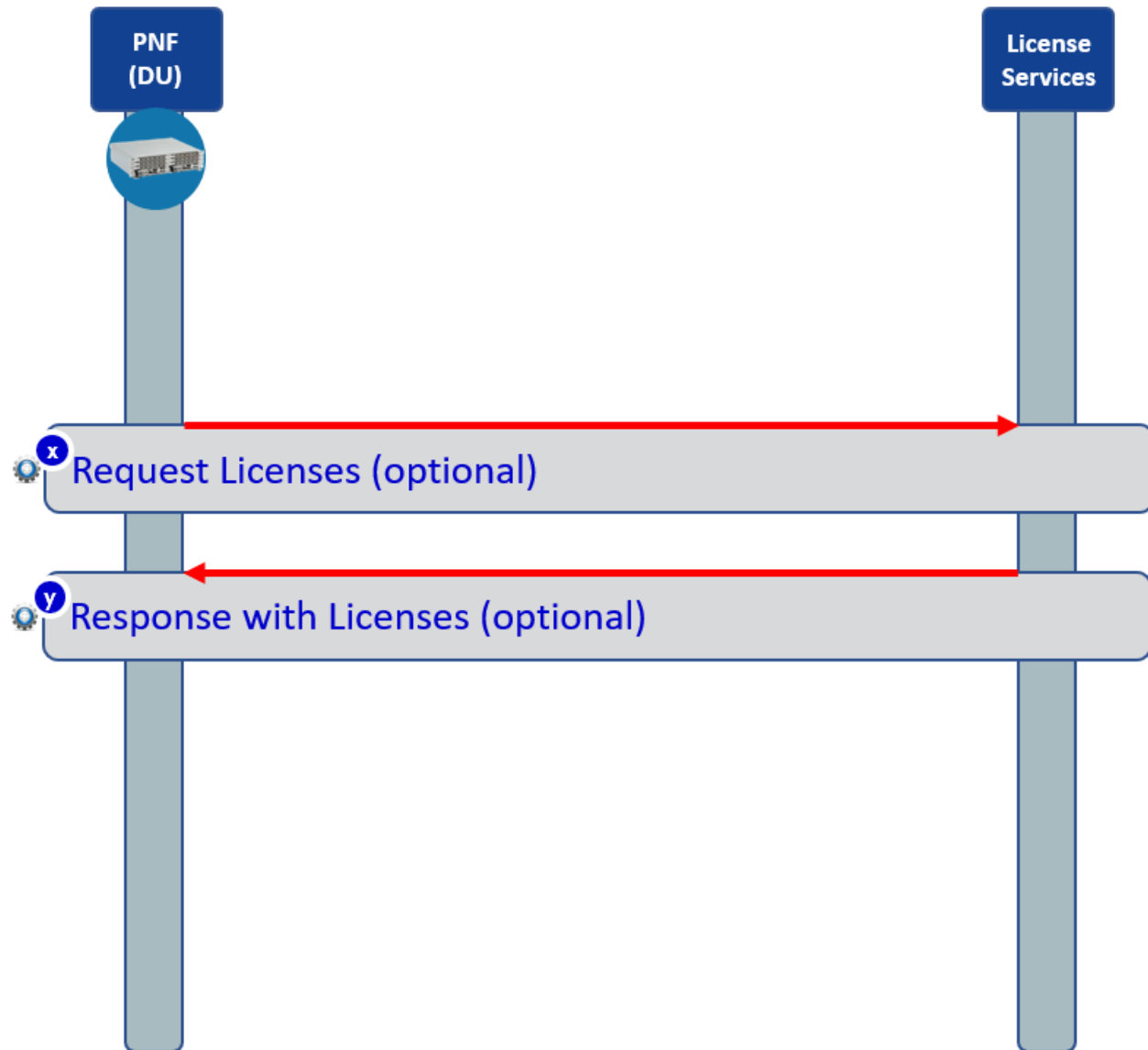

PNF PLUG AND PLAY for R8 Honolulu



<https://wiki.onap.org/display/DW/R7+PNF+Plug+and+Play+PnP>

R8 NEW COMPONENT CAPABILITIES	DESCRIPTION
VID	<p>VID development for SO BB Instantiations screens in VID Modern UI for PNFs they are currently empty. Left (model components) / Right pane (instance components) – service PNF instances Today Left pane is blank, need to enable that to setup parameters for PNF instance. Similar to VNF (but with reduce scope). Adapt the SO API built in R7. Building the PNF instantiation screens within VID. The corresponding VNFs already exist, and likely the update will look at these and modify and adapt them to the PNF.</p>
(STUDY)	<p><u>STUDY</u> (no code implemented) In R8, we will study how the complex/Place object might be created and used during Plug and play. It is possible that while executing (<i>needs to be investigated</i>) that the AssignPNFBB Building Block in SO, to associate AAI Entry of PNF with Place Object</p> <p>Note: Somewhere in the PnP Registration flow, an instance of the Place object needs to be associated w/ the PNF: FLOW: DU (PNF) sends a pnfRegistration VES event. AssignpnfBB (BB) the A&AI entry is created. (AAI SETUP) (a) where it is created and where it is updated (AAI UPDATE) (b) ConfigAssignPnf (BB) what is run AFTER the PRH receives the pnfRegistration VES event and published a PNFready onto the DMaaP</p>

Wiki

R8 Honolulu NEW COMPONENT CAPABILITIES

INTERFACES & APIs



R8 Honolulu Interfaces Impacts

R8 Interfaces	IMPACT
VID	No CHANGE to SO API New code to USE SO APIs developed in R7 R8 code: new VID calls to SO BB API I/Fs

R8 Honolulu APIs Impacts

R8 API	IMPACT
SO / VID	No API changes are expected.

MODELING IMPACTS



R8 Model	IMPACT
(None)	No Model impact Just investigating to see how the Place object might be created & assigned during PnP
	Place Model is here: https://wiki.onap.org/display/DW/Proposed+Location+Model

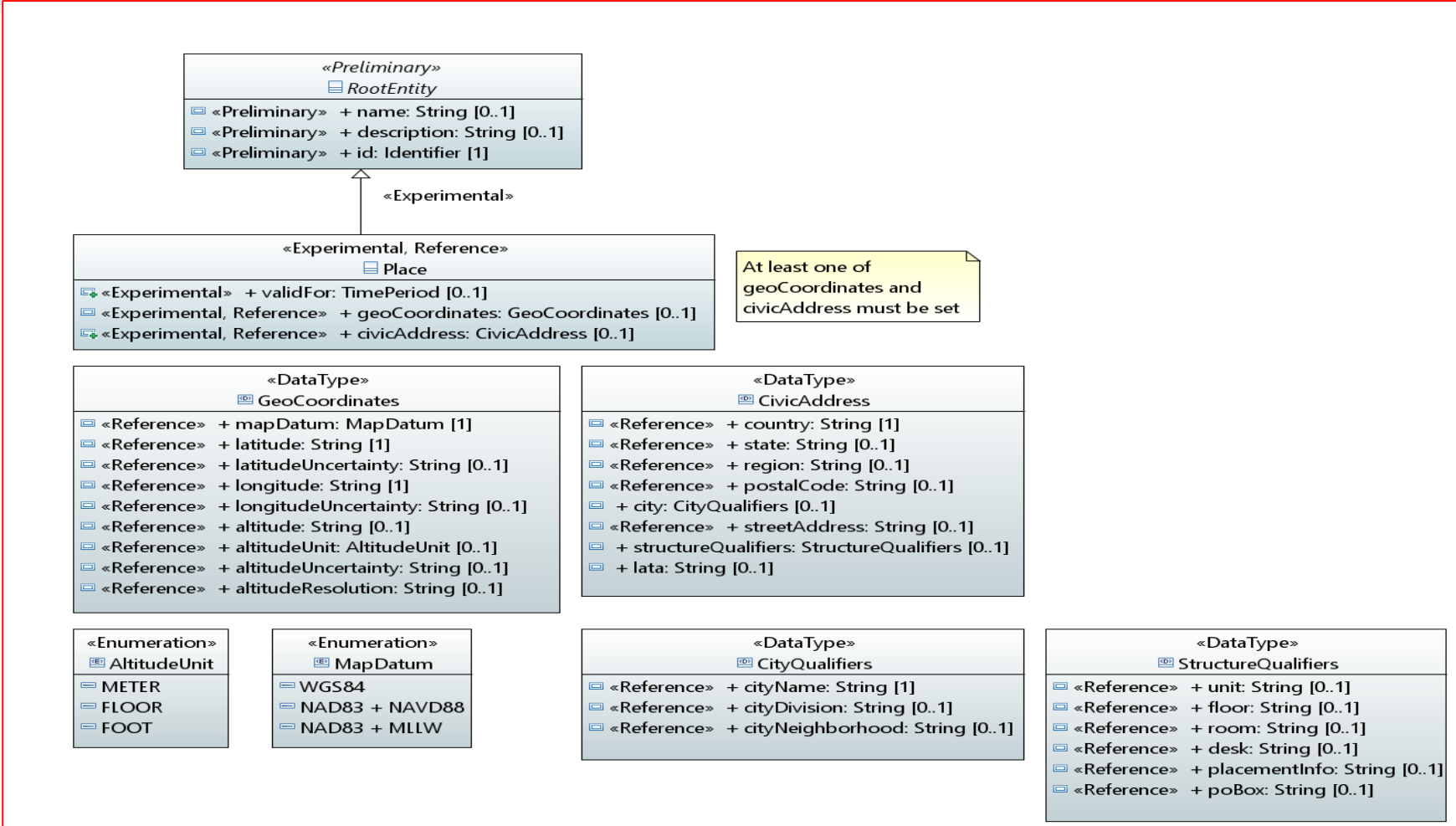

R8 CERTIFICATE MANAGEMENT PROTOCOL V2



- R8 Architecture Sub-committee Presentation

CERTIFICATE MANAGEMENT PROTOCOL (CMP)

The Certificate Management Protocol (CMP) is an Internet protocol used for obtaining X.509 digital certificates in a public key infrastructure (PKI). It is described in RFC 4210 and is one of two protocols so far to use the Certificate Request Message Format (CRMF), described in RFC 4211, with the other protocol being Certificate Management over CMS (CMC), described in RFC 5273. An obsolete version of CMP is described in RFC 2510, the respective CRMF version in RFC 2511. CMP messages are encoded in ASN.1, using the DER method and usually transported over HTTP. CMP (Certificate Management Protocol) Server & Client (completed in R6)

ARCHITECTURE REQUIREMENT IDENTITY – ROW 18

AR-0017-R7-052020 Guilin release - functional requirements proposed list#R7ONAPSECURITY-CMPv2SERVER/CLIENTINTEGRATION Benjamin Cheung, Pawel Baniewski, Hampus Tjäder xNF

EXECUTIVE SUMMARY - The CMPv2 work in R8 will develop (1) Integration with Cert-Manager (certificate enrollment solution recommended by OOM) and (2) DCAE further integration (expected to be completed by R7 bug fixes). This requirement improves ONAP Security with CMPv2. CMP is used by multiple operations including Plug and Play, and NetConf operation. In R6 CMPv2 Certificate Service and basic development was implemented. Integration with server & client to the certificate service was completed. There are also two ONAP bordering component that were integrated with the certificate service with interfaces to SDN-C and DCAE. See the REQ-431: <https://jira.onap.org/browse/REQ-431?src=confmacro>

BUSINESS IMPACT - The enhancement to CMPv2 operation will improve security management within ONAP and affects multiple ONAP functions and use cases, including Plug and Play (PNF registration) and NetConf. As with all security functionality within ONAP, Security is a fundamental aspect of FCAPS, being the "S" for security management.

BUSINESS MARKETS - This project applies to any domain (wireless, transport, optical, and wireline) that ONAP may manage.

FUNDING/FINANCIAL IMPACTS - Potential OPEX savings with enhanced security to prevent breaches and prevent security compromises.

ORGANIZATION MGMT, SALES STRATEGIES - There is no additional organizational management or sales strategies for this use case outside of a service providers "normal" ONAP deployment and its attendant organizational resources from a service provider.

CERTIFICATE MANAGEMENT PROTOCOL (CMP)

CMP in the TCP/IP model:

application	CMP	CMP			
		HTTP	HTTPS	SMTP	..
transport		TCP			
Internet		IP (IPv4, IPv6)			
link	Ethernet	Token Bus	Token Ring	FDDI	..

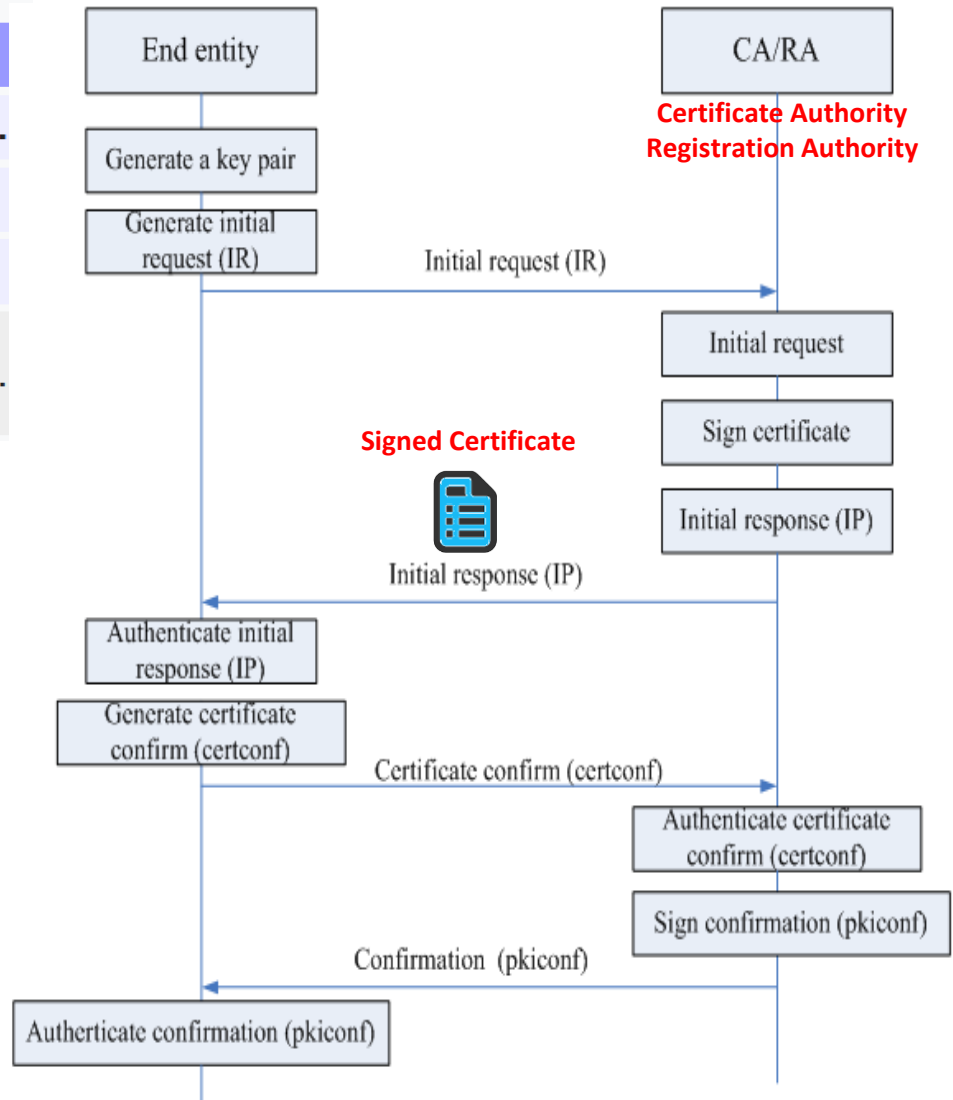

CMP v2 for R8 Honolulu

Wiki

<https://wiki.onap.org/pages/viewpage.action?pageId=84640858>

R8 Honolulu NEW COMPONENT CAPABILITIES

R8 NEW COMPONENT CAPABILITIES	IMPACT DESCRIPTION
CMP v2 enhancements	<p>Integration with Cert-Manager (certificate enrollment solution recommended by OOM)</p> <ul style="list-style-type: none">• Implementation of external provider compatible with newest version of Cert-Manager (at the of writing - 1.0.2)• Adjustment of existing ONAP CMPv2 integrations (SDNC and DCAE) to use integration with Cert-Manager
CMP v2 enhancements	<p>DCAE further integration:</p> <ul style="list-style-type: none">• Integration with Data File Collector (DFC)<ul style="list-style-type: none">- Supports two I/F: SFTP FTPES (uses X.509 cert) enroll from CMPv2 server to protect I/F. HTTP support. Collect files via these protocols. For HTTP server, traffic would like certificate enrolled from CMP server (possibly dedicated server). New REQ.• Integration with RestConf Collector (RCC)<ul style="list-style-type: none">- no ability to test such integration - need to check this with Huawei- Huawei so far tested only with real equipment. The community does not have access to the equipment- The RestConf simulator is not available yet to the community. Either (1) provide simulator or (2) testing changes on their real equipment- if Huawei doesn't agree to test CMPv2 changes this part will be dropped• Adding native Kafka stream support to BP generator which blocked HV-VES component spec modification in Guilin release
CMP v2 integration/testing	<p>Testing and Integration with new changes. (See above related to RestConf simulator availability OR testing w/ Huawei real equipment). Testing DFC in Bulk PM use case.</p>

INTERFACES & APIs

R8 Honolulu Interfaces Impacts

R8 Interfaces	IMPACT
CMP v2	DCAE bordering components will have certificate for external traffic from CMPv2 server. (New S/W development) Previously certificate e.g. contact VES , cert from AAF Cert-man. Get CMPv2 server instead of AAF cert-man. (only these two things try to get cert. from AAF); only select components not all of DCAE platform. R7 Introduced for VES, HVVES; In R8 introduced for DFC and RCC.

R8 Honolulu APIs Impacts

R8 API	IMPACT
CMP v2	No API change.

MODELING IMPACTS

R8 Honolulu Modeling Impacts

R8 Model	IMPACT
(None)	(None)

R8 DUAL STACK IPv4 / IPv6 Support (GR)



- **R8 Architecture Sub-committee Presentation**

DUAL STACK IPv4/IPv6 Concept

"Dual Stack" Will Deliver IPv6 Connectivity.

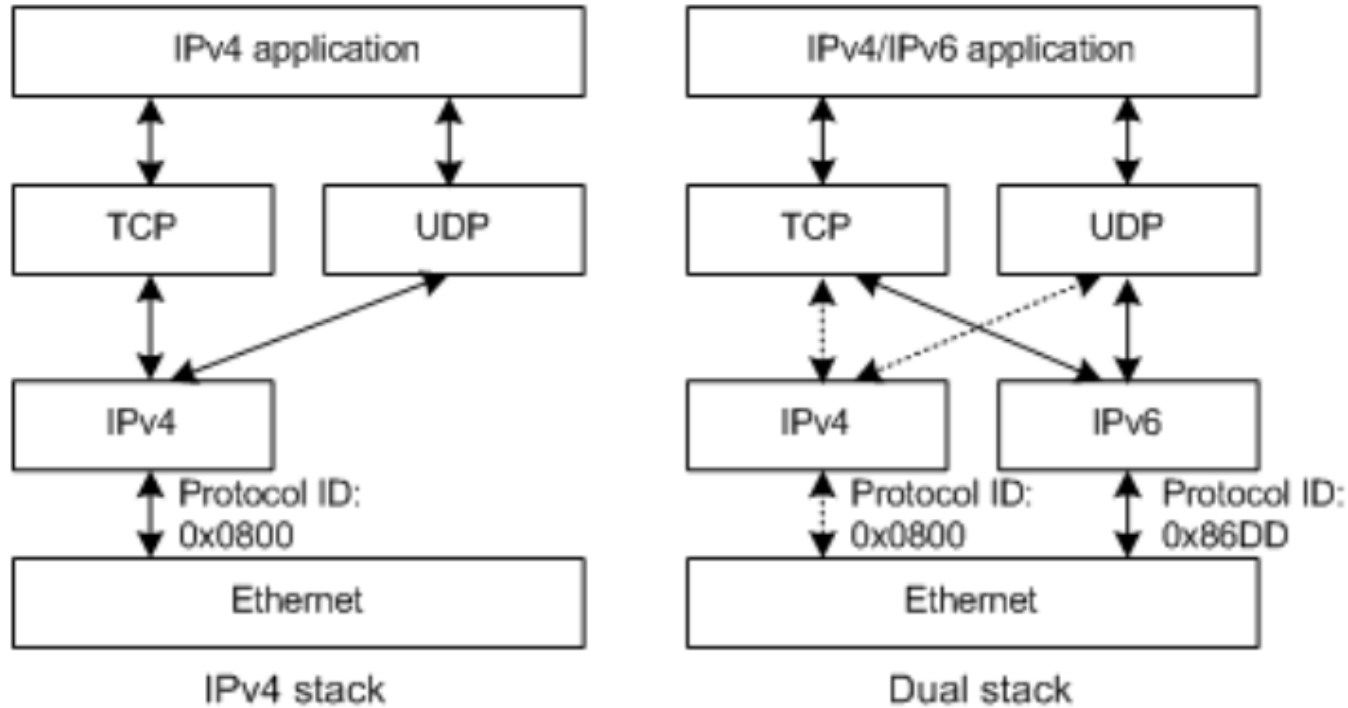

Until we're an IPv6-only world, people need to have connectivity, whether the connection is IPv4-to-IPv4 or IPv6-to-IPv6

DUAL STACK IPv4/IPv6 IN R8

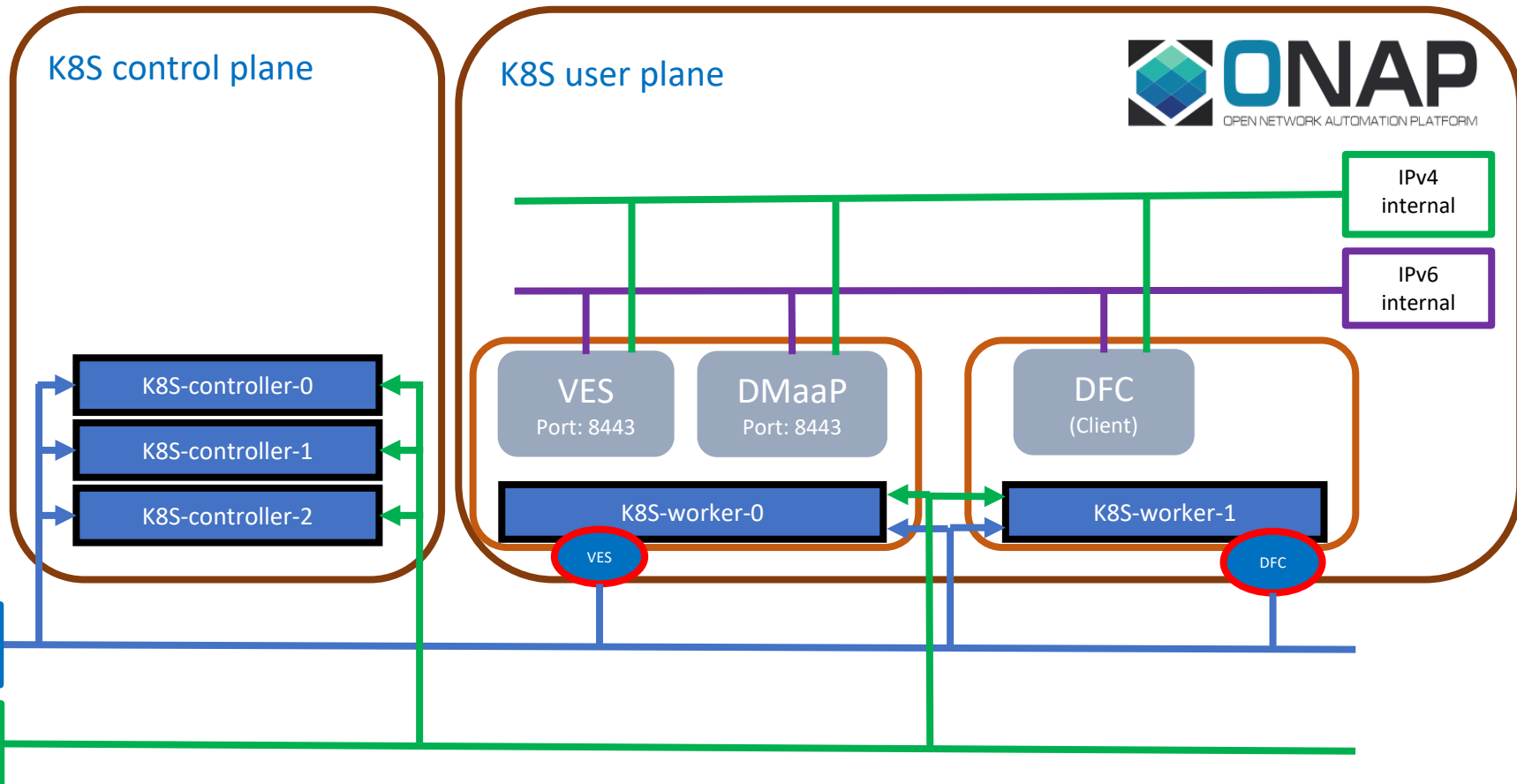

DUAL STACK IPv4/IPv6 IN R8

Req Use Case - DESCRIPTION

Majority of LTE and 5G RAN networks today are running exclusively on IPv6. IPv4/IPv6 dual stack solution for ONAP is needed to enable integration.

Continuation of <https://jira.onap.org/browse/REQ-385>

It is mainly about a Kubernetes platform, hosting ONAP application containers.

An enabler for IPv4/IPv6 networking would be an upgrade of ONAP OOM Helm charts to K8S 1.16+ APIs (Done in Guilin). R8 this work is done by <https://jira.onap.org/browse/REQ-432>

ARCHITECTURE REQUIREMENT IDENTITY – ROW 18

BUSINESS DRIVERS

EXECUTIVE SUMMARY - Majority of LTE and 5G RAN networks today are running exclusively on IPv6. IPv4/IPv6 dual stack solution for ONAP is needed to enable integration.

There is also a requirement to register the NetConf network devices in SDN-R controller, using IPv6 networking.

UPDATE COMPONENTS TO SUPPORT DUAL STACK - The target for R8 Honolulu is to update all ONAP components which do not install/execute properly in IPv4/IPv6 dual stack environment. As of today (October/2020), the following components are affected. **SUBJECT TO CHANGE** :

- SDN-R Elastic Search module
- Portal MariaDB database
- DCAE - CFY Plugin - support exposing services using IPv6
- Et. al. (TBD)

KUBERNETES 1.18 - Additionally, we'd like to make sure, that ONAP CI/Gating environment is running RKE-Kubernetes 1.18.x (at least). deployment and its attendant organizational resources from a service provider. Experimental K8S platform (**may already be done in R7**)

DUAL STACK IPv4/IPv6 IN R8

EXECUTIVE SUMMARY -

Majority of LTE and 5G RAN networks today are running exclusively on IPv6. IPv4/IPv6 dual stack solution for ONAP is needed to enable integration.

There is also a requirement to register the NetConf network devices in SDN-R controller, using IPv6 networking.

UPDATE COMPONENTS TO SUPPORT DUAL STACK - The target for Honolulu is to update all ONAP components which do not install/execute properly in IPv4/IPv6 dual stack environment. As of today (October/2020), the following components are affected:

- SDN-R Elastic Search module
- Portal MariaDB database
- SDC/AAI Cassandra database
- DCAE - CFY Plugin - support exposing services using IPv6
- Et. al. (TBD)

KUBERNETES 1.18 - Additionally, we'd like to make sure, that ONAP CI/Gating environment is running RKE-Kubernetes 1.18.x (at least). deployment and its attendant organizational resources from a service provider.

BUSINESS IMPACT- Improves ONAP integration capabilities, mainly in 5G use-cases and E2E Network Slicing. Future-proofs ONAP for years to come. Allows to use AKS/EKS/GKS (* managed Kubernetes Service) to deploy ONAP in public clouds.

BUSINESS MARKETS - All operators, service providers and entities using ONAP.

FUNDING/FINANCIAL IMPACTS – None. RKE is already supporting K8S 1.18 as one of recommended K8S solutions, thus no additional costs here.

ORGANIZATION MGMT, SALES STRATEGIES - This proposal does not affect sales strategies.

NEW COMPONENT CAPABILITIES R8

Wiki

(Wiki link TBD)

R8 Honolulu NEW COMPONENT CAPABILITIES

R8 NEW COMPONENT CAPABILITIES

DESCRIPTION

SDN-R, Portal Maria DB, SDC/A&AI Cassandra DB, DCAE (CFY Plugin)

UPDATE COMPONENTS TO SUPPORT DUAL STACK - The target for Honolulu is to update all ONAP components which do not install/execute properly in IPv4/IPv6 dual stack environment. As of today (October/2020), the following components are affected (**SUBJECT TO CHANGE**):

- SDN-R Elastic Search module
- Portal MariaDB database
- DCAE - CFY Plugin - support exposing services using IPv6
- Et. al. (TBD)

KUBERNETES 1.18

KUBERNETES 1.18 - make sure that ONAP CI/Gating environment is running RKE-Kubernetes 1.18.x (at least). deployment and its attendant organizational resources from a service provider.
NOTE: Experimental K8S platform (**may already be done in R7**)

INTERFACES & APIs

R8 Honolulu Interfaces Impacts

R8 Interfaces	IMPACT
None	No Interface Changes

R8 Honolulu APIs Impacts

R8 API	IMPACT
(TBD)	No expected API changes as of yet; however, there might be API changes resulting from new versions of existing components No such risk yet.

MODELING IMPACTS

R8 Honolulu Modeling Impacts

R8 Model	IMPACT
(None)	(None)

R8 STANDARD DEFINED VES



- R8 Architecture Sub-committee Presentation

ONAP/3GPP & ORAN Alignment in R8 Guilin

Logical Architecture of O-RAN—ONAP as O-RAN compliant SMO

ONAP is concerned with O1, O2 and A1 interfaces ONLY.

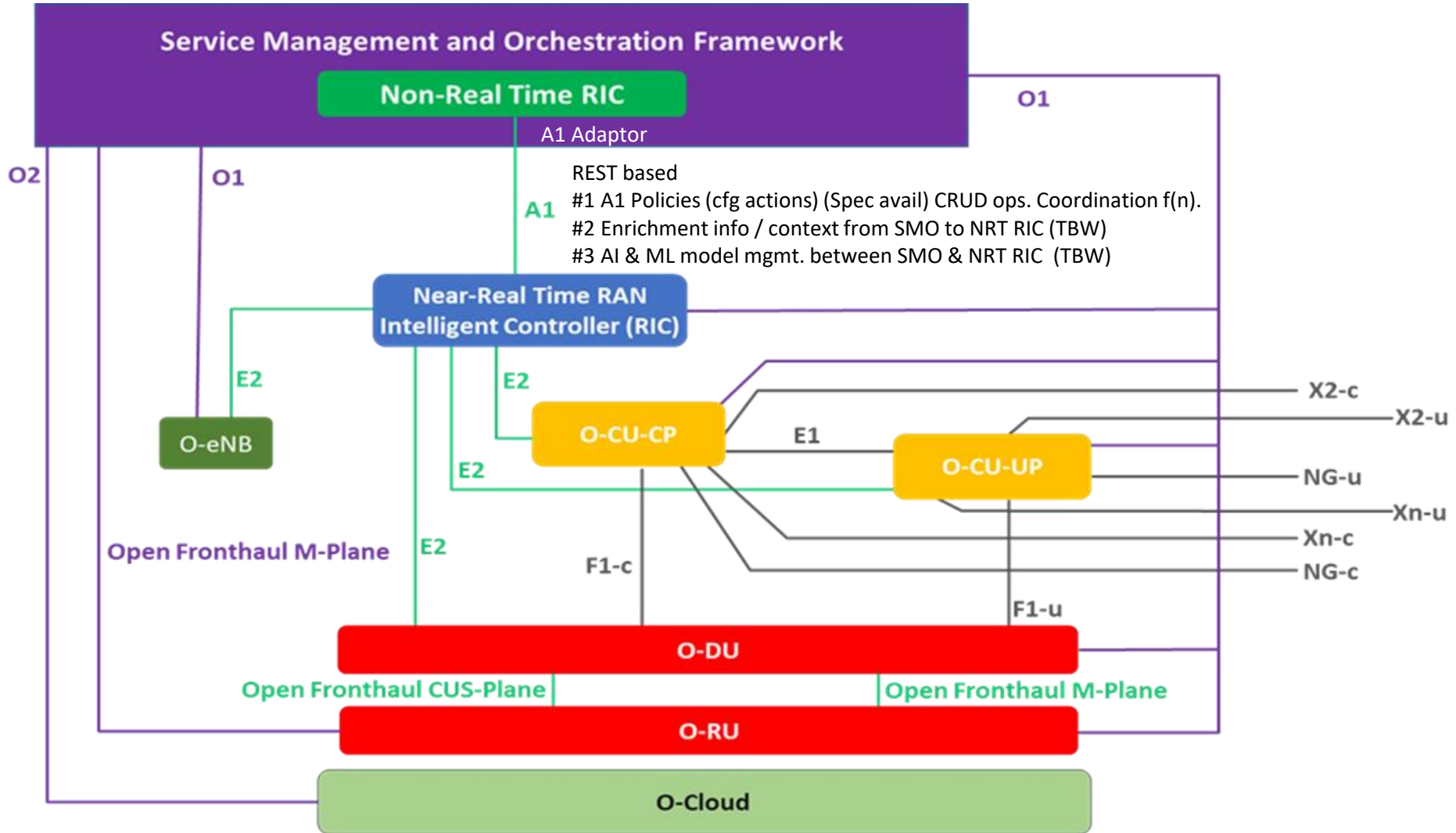

R7 ONAP/3GPP & ORAN Alignment



StdDefined VES Event from PNF

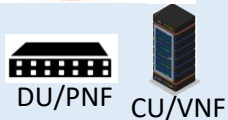

PNF
VNF

VES
Event

Standards Defined
VES Event
for Configuration

The PNF has a parameter update to report. The update originates from the PNF and is reported through a Standards Defined VES event with a configuration NameSpace (3GPP-Provisioning)

1

DCAE VES
Collector

Standards Defined VES Event is received by the *DCAE VES Collector*. DCAE publishes the VES Event onto the DMaaP Bus.

ONAP
RUN-TIME



DCAE
Analytics

Configuration NameSpace topic
3GPP-Provisioning

CPS Update

In R8+: CPS as a stand-alone component, subscribes to the DMaaP Topic and gets the DMaaP event from the DMaaP bus to update the internal database. The VES event has a Configuration namespace topic, 3GPP-Provisioning

DMaaP

Configuration
Persistence
Service



CPS Database

Run-Time Operational Data
Configuration Info
Exo-Inventory Data
RT Logical & Physical Connections

ONAP/3GPP & ORAN Alignment in R8 Guilin

EXECUTIVE SUMMARY -

- This is a continuation of the <https://jira.onap.org/browse/REQ-327>
- This contribution introduces enhancements (mainly to DCAE platform) to support better the standard-defined openAPI onboarding (at least as a K8S configMap in DCAE)
- This contribution introduces openAPI onboarding capabilities (openAPI as an onboarding package artifact, distribution to relevant ONAP modules, ingesting in interested ONAP modules)

BUSINESS IMPACT- The ability for service providers to deploy ONAP as the SMO in their O-RAN compliant network depends upon ONAP's ability to process VES encapsulated events as defined by 3GPP and ORAN in DCAE and route these events to appropriate DMaaP topics. This proposal, in Guilin, provides the necessary capability for ONAP to process and validate events that are defined using 3GPP schema for the data. The proposal is readily extensible for the support of additional events from 3GPP, ORAN or other standards organizations adding a high degree of flexibility to the ONAP platform.

BUSINESS MARKETS - This contribution applies to any Service Provider that wants to use ONAP as an O-RAN compliant SMO or to support 3GPP compliant interfaces and can be leveraged by Service Providers wishing to support events from network functions which are aligned with other standards organizations.

FUNDING/FINANCIAL IMPACTS - This contribution helps enable ONAP to be O-RAN and 3GPP compliant which should stimulate contributions from companies that are aligned with O-RAN and 3GPP. There is no new hardware to be procured and no new licenses.

ORGANIZATION MGMT, SALES STRATEGIES - This proposal does not affect sales strategies.

- 1) Standards organization is intended to be interpreted in a broader sense than SDO as defined by ITU, to cover also e.g. joint ventures like 3GPP and open industry fora like the O-RAN Alliance.

ONAP/3GPP & ORAN Alignment – *Standards Defined* Event in VES

U/C DESCRIPTION

ONAP 3GPP & ORAN Alignment Standard Defined Event in VES

This use case uses a new domain in VES, `stdDefined`, which indicates that the event contains data that conforms to format/schema defined by a separate standards organization, such as 3GPP. There is a new field in the VES Common Header to enable further classification of such events, e.g. to support routing of these events to appropriate DMAAP topics. An optional second stage validation is proposed in DCAE prior to acknowledging the event to enhance trouble shooting. The first application of this generic capability supports VES encapsulated 3GPP defined notifications as described in 28.532 version 16.3.0 Annex B (informative). The ORAN O1 specification also refers to VES-based 3GPP notifications for several management services, and in those cases is expected to further align with the approach and solution published in 3GPP in a future release. Done with <https://jira.onap.org/browse/REQ-433>

Wiki

[Wiki TBD](#)

R8 Honolulu ENHANCEMENTS

R8 CANDIDATE ENHANCEMENTS

IMPACT

DCAE

This contribution introduces enhancements (mainly to DCAE platform) to support better the standard-defined openAPI onboarding (at least as a K8S configMap in DCAE).
[Scripts to generated to generate a K8S configMap attached to DCAE modules \(localized to DCAE\)](#)
This work is a continuation of the <https://jira.onap.org/browse/REQ-327>

[openAPI onboarding \(package onboarding, distribution\)](#)

This contribution introduces openAPI onboarding capabilities (openAPI as an onboarding package artifact, distribution to relevant ONAP modules, ingesting in interested ONAP modules)
Broader – repo of openAPI descriptors; onboard it as an artifact.

SDC

SDC – add a new artifact type

INTERFACES & APIs

R8 Honolulu Interfaces Impacts

R8 Interfaces	IMPACT
None	No Interfaces are impacted

R8 Honolulu APIs Impacts

R8 API	IMPACT
None	No API changes are affected

R7 (Guilin) MODELING IMPACTS

R8 Model	IMPACT
(None)	Existing StndDef VES is defined in the Modeling wiki: https://wiki.onap.org/display/DW/VES+7.2 No new modeling work is planned for this Use Case in R8 Honolulu
	Database Schema & REST APIs. Currently under review by Modeling S/C Expected to be baselined Nov 17, 2020.

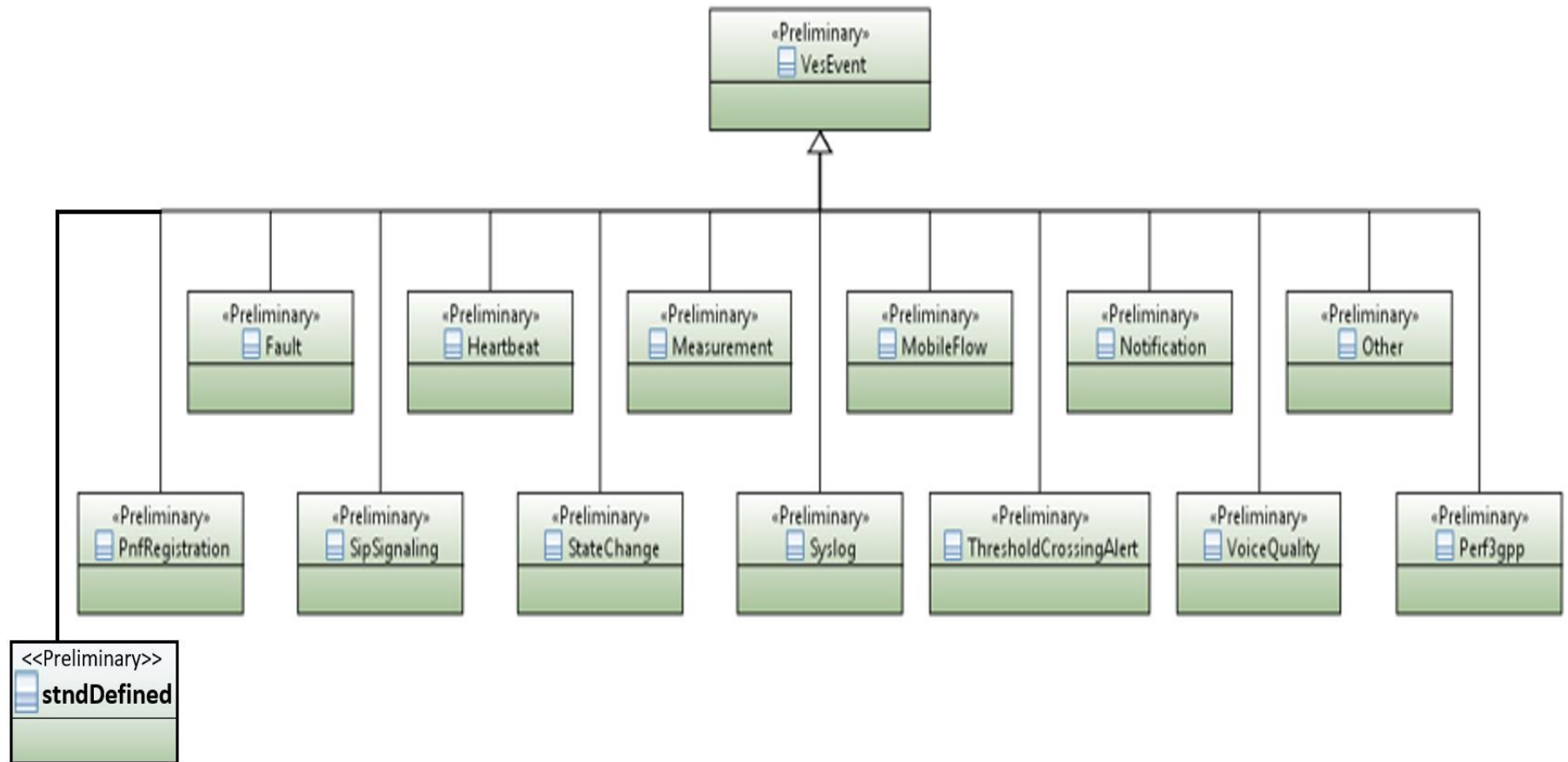

R7 (Guilin) MODELING IMPACTS

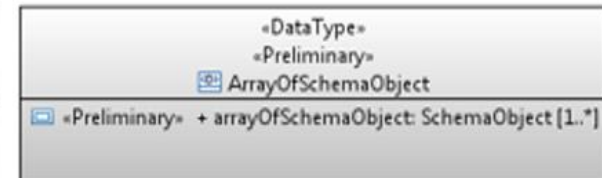
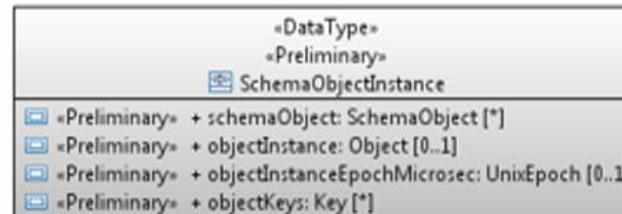
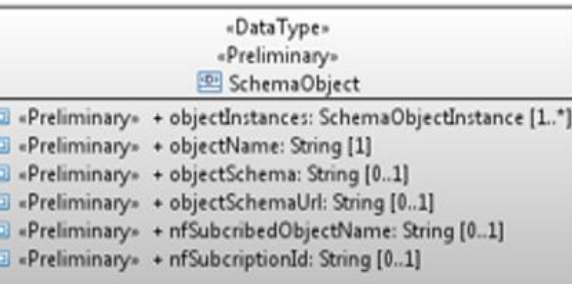
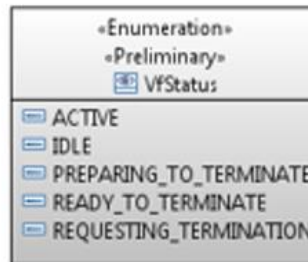
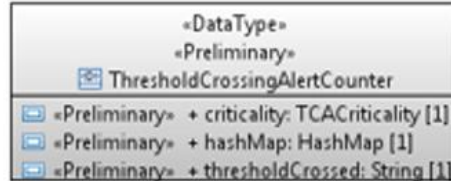
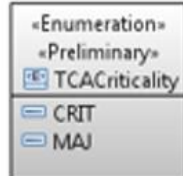
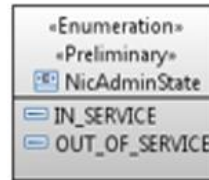
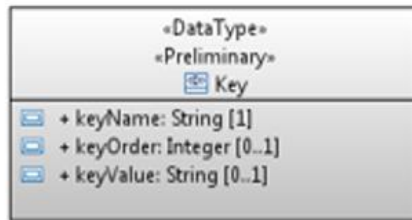
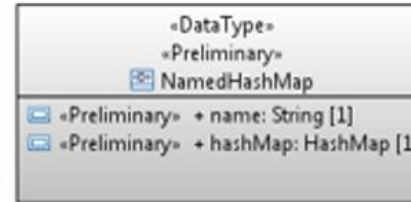
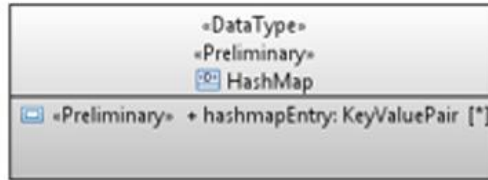
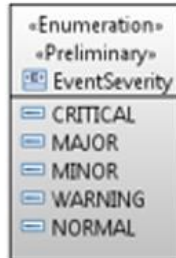
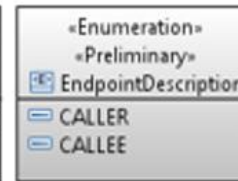
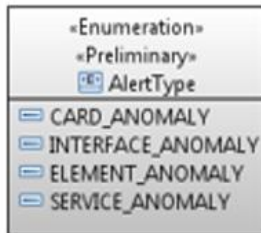
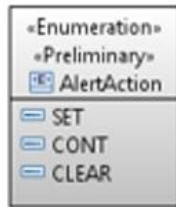

QUESTIONS





APPENDIX

Brief Project Overview (brief as it should be known)

(Referenced to existing documentations is highly encouraged for the purpose of keeping this document up to date)

New component capabilities for Guilin, i.e. the functional enhancements, if applicable

New or modified interfaces

If they are modified, are they backwards compatible?

Interface naming (point to an example)

Consumed API from other platform projects (A&AI, DCAE, SO)

Published API

Reference to the interfaces.

(Reference to the the swagger.json file(s) whenever possible)

What are the system limits?

Involved use cases, architectural capabilities or functional requirements.

Listing of new or impacted models used by the project (for information only).

- Identify any High Level Information Model Requirements. See: [ONAP R7 Modeling High Level Requirements](#)
 - Models based on information exchanges from Use Cases
 - Models documenting existing implementations
 - Forward looking models that may be implemented in future releases
- Describe how exposed APIs are mapped to information models
(list all the relevant Jira tickets)

Any other details that are specific to this functional enhancement or UseCase.

Testing/Integration